

Fig. 1, FA 15 and 20

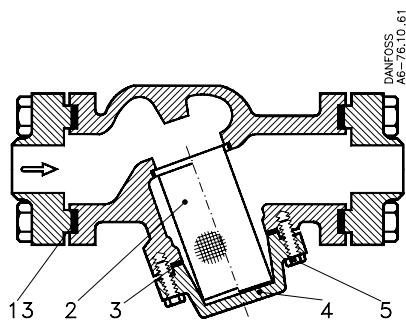

Fig. 2, FA 25

Description	Qty	FA 15	FA 20	FA 25
		Code no.	Code no.	Code no.
Repair kit, figs. 1 and 2		006-0331	006-0332	006-0333
Pos. 2 Strainer	1			
3 Cover gasket	1			
5 Screw	4*			
Seal kit, figs. 1 and 2		006-0334	006-0335	006-0336
Pos. 3 Cover gasket	1			
13 Flange gasket	2			
Seal kit, fig. 1			006-0346**	
Pos. 3 Cover gasket	1			
13 Flange gasket	2			

*) For FA 25: 6 pcs.

***) For FA 20 strainers,
Code nos. 006-0046, 006,0048, 036-0062
Dimensions of flange gaskets: ID 29 x OD
39 x 1.5 mm