



Stop check valves
type SCA 15 - 125

Check valves
type CHV 15 - 125

Content

	Page
Introduction.....	3
Features.....	3
Technical data.....	4
Design.....	4
Computation and selection.....	5
Application.....	7
Material specification.....	8
Connections.....	10
Dimensions and weights.....	11
SCA/CHV 15 - 40 (1/2 - 1 1/2 in.).....	11
SCA/CHV 50 - 65 (2 - 2 1/2 in.).....	12
SCA/CHV 80 - 125 (3 - 5 in.).....	13
Ordering.....	14

Introduction

SCA are check valves with a built-in stop valve function. CHV are check valves only.

The valves are designed to open at very low differential pressures, allow favourable flow conditions and are easy to disassemble for inspection and service.

SCA are equipped with vented cap and have internal backseating enabling the spindle seal to be replaced whilst the valve still under pressure.

Laser cut V-ports provide excellent opening characteristics.

The valve cone has a built-in flexibility to ensure a precise and tight closing towards the valve seat.

A well balanced dampening effect between the piston and the cylinder gives an optimal protection during low loads and against pulsations.

Features

- Applicable to all common non flammable refrigerants including R717 and non corrosive gases/liquids dependent on sealing material compatibility
- Designed to open at a very low differential pressure of 0.04 bar (0.58 psig)
- Designed with a built-in damping chamber preventing valve flutter, due to low refrigerant velocity and/or low density
- Each valve is clearly marked with type, size and performance range
- Easy to disassemble for inspection and service
- Internal backseating enables replacement of the spindle seal whilst the valve is active, i.e. under pressure
- Optimal flow characteristics ensuring quick opening to the fully open position
- Protection against pulsation by built-in damping facility
- Material on housing and bonnet are in low temperature steel according to requirements of the Pressure Equipment Directive and other international classification authorities
- Stainless steel bolts
- Pressure range
SCA/CHV 40 bar g (580 psig)
- Temperature range
-60°C/+150° (-76°F/+302°F)
- Classification: To get an updated list of certification on the products please contact your local Danfoss Sales Company.

Design

Connections

Available with the following connections:

- Welding DIN (2448)
- Butt-weld ANSI (B 36.10 Schedule 80),
- DN 15 - 40 (½ - 1½ in.)
- Butt-weld ANSI (B 36.10 Schedule 40),
- DN 50 - 200 (2 - 8 in.)

Housing

Made from special, cold resistant steel approved for low temperature operations.

Valve Cone

Valve cone with built in metallic stop - prevents damage to teflon ring in case of overtightening.

Damping chamber

The chamber is filled with refrigerants (gas or liquid), which provides a damping effect, when the valve opens and closes.

Spindle (SCA)

Made of polished stainless steel, which is ideal for O-ring sealing.

Packing Gland (SCA)

The "full temperature range" packing gland consists of a double O-ring sealing arrangement combined with permanent lubrication from a grease reservoir. This ensures perfect tightness throughout the whole temperature range: -60/+150°C (-76/+302°F).

Pressure Equipment Directive (PED)

The SCA / CHV valves are approved and CE marked in accordance with Pressure Equipment Directive - 97/23/EC.

For further details / restrictions - see Installation Instruction.

Installation

The valve must be mounted vertically with the cone downwards.

The valve is designed to resist very high internal pressure. However, the piping system in general should be designed to avoid liquid traps and reduce the risk of hydraulic pressure caused by thermal expansion.

For further information refer to installation instructions for SCA/CHV.

If cold refrigeration oil having low viscosities enters and settles in the damping chamber, problems with the check valve may arise. Consequently, it may be necessary to modify the valve for more viscous liquids by enlarging the hole to the damping chamber.

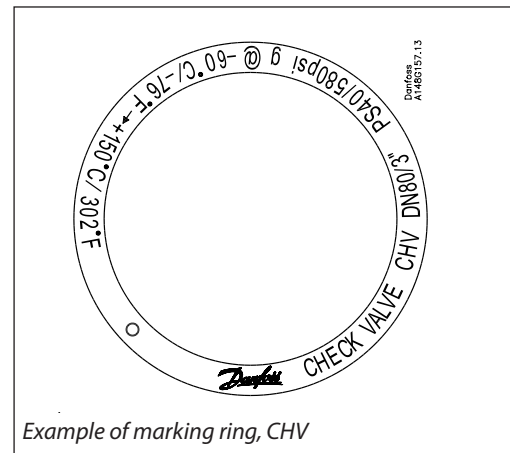

SCA / CHV valves			
Nominal bore	Standard application	DN 50-80 mm (2-3 in.)	DN 100-125 mm (4-5 in.)
	High pressure application	DN 50-65 mm (2-2½ in.)	DN 80-125 mm (3-5 in.)
Classified for	Fluid group I		
Category	II		III

Technical data

- *Refrigerants*
Applicable to all common non flammable refrigerants including R717 and non corrosive gases/liquids dependent on sealing materials compatibility.
For further information refer to installation instruction for SCA/CHV.
Flammable hydrocarbons are not recommended. For further information please contact your local Danfoss Sales company.

- *Temperature range*
-60/+150°C (-76/+302°F).
- *Pressure range*
The valves are designed for:
Max. working pressure: 40 bar g (580 psig).

Valves for higher working pressure are available on request.

Computation and selection

Introduction

When dimensioning SCA/CHV, it is important to select a valve that is best suited to all operating conditions. Therefore, it is necessary to consider both the nominal and part load working conditions.

Example

SI-Units

Assumed working conditions:
 Maximum flow $\dot{V} = 1000 \text{ m}^3/\text{h}$
 Density $\rho = 3.0 \text{ kg/m}^3$
 Minimum part load = 33%

Used expressions:

Recommended velocity - C_{rec} [m/s]
 Minimum recommended velocity - $C_{min, rec}$ [m/s]
 Maximum velocity - C_{max} [m/s]
 Part load velocity - C_{part} [m/s]

We know the density $\rho \approx 3.0 \text{ kg/m}^3$, consequently C_{rec} as well as $C_{min, rec}$ can be found in the figure (standard valve).

$C_{rec} \approx 14 \text{ m/s}$
 $C_{min, rec} \approx 3 \text{ m/s}$

US-Units

Assumed working conditions:
 Maximum flow $\dot{V} = 1160 \text{ gpm}$
 Density $\rho = 0.187 \text{ lb/feet}^3$
 Minimum part load = 33%

Used expressions:

Recommended velocity - C_{rec} [ft/min]
 Minimum recommended velocity - $C_{min, rec}$ [ft/min]
 Maximum velocity - C_{max} [ft/min]
 Part load velocity - C_{part} [ft/min]

We know the density $\rho \approx 0.187 \text{ lb/feet}^3$, consequently C_{rec} as well as $C_{min, rec}$ can be found in the figure (standard valve).

$C_{rec} \approx 2756 \text{ ft/min}$
 $C_{min, rec} \approx 591 \text{ ft/min}$

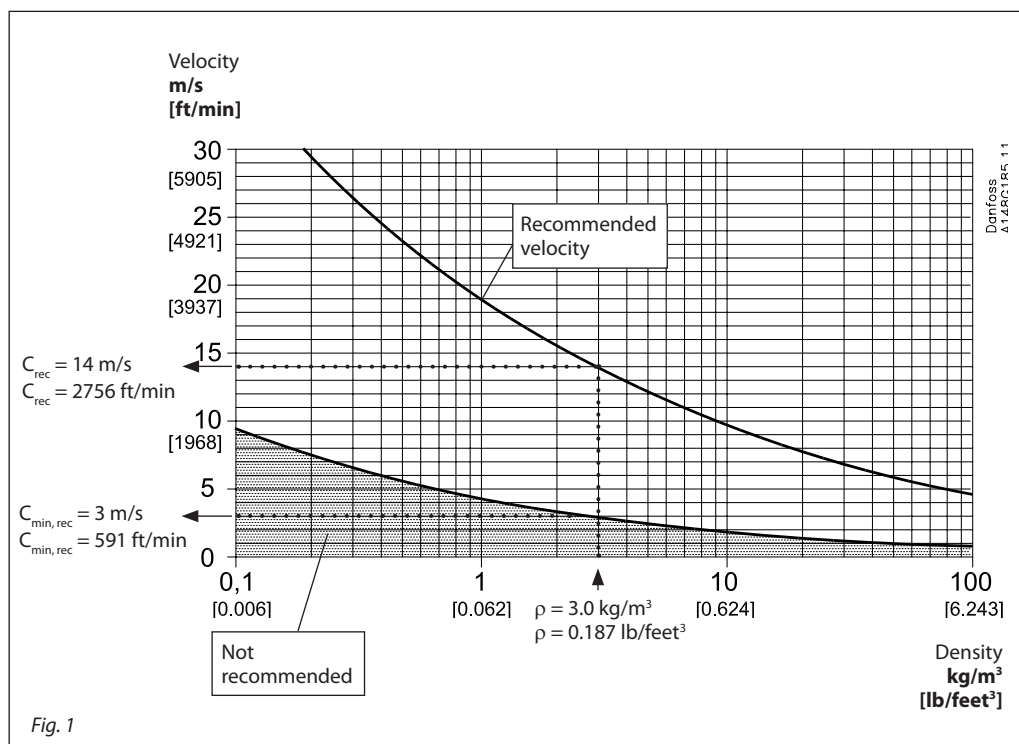

Selection example continued on following page.

Computation and selection
(continued)

Knowing that $\dot{V} = 1000 \text{ m}^3/\text{h}$ (1160 gpm) fig. 2 gives the following choices:

- For SCA/CHV in size DN 100 the maximum velocity $C_{\text{max}} \approx 31 \text{ m/s}$ (6100 ft/min)
- For SCA/CHV in size DN 125 the maximum velocity $C_{\text{max}} \approx 20 \text{ m/s}$ (3900 ft/min)

In conclusion SCA in size DN 125 is selected because $C_{\text{max}} \approx 20 \text{ m/s}$ (3900 ft/min) comes nearest to the recommended velocity $C_{\text{rec}} \approx 14 \text{ m/s}$ (2756 ft/min) and at the same time part load conditions fulfil the requirements, as described:

If the valve in question, for instance under part load conditions provides a velocity less than $C_{\text{min,rec}}$ the valve might start hammering and become noisy. As a result the valve may wear prematurely.

We know that $C_{\text{max}} \approx 20 \text{ m/s}$ (3900 ft/min) and that minimum part load is 33%. It follows that $C_{\text{part}} \approx 6.5 \text{ m/s}$ (1290 ft/min). Thus, $C_{\text{part}} (6.5 \text{ m/s}) > C_{\text{min,rec}} (3.0 \text{ m/s})$ and the selected SCA model DN125 is the perfect choice.

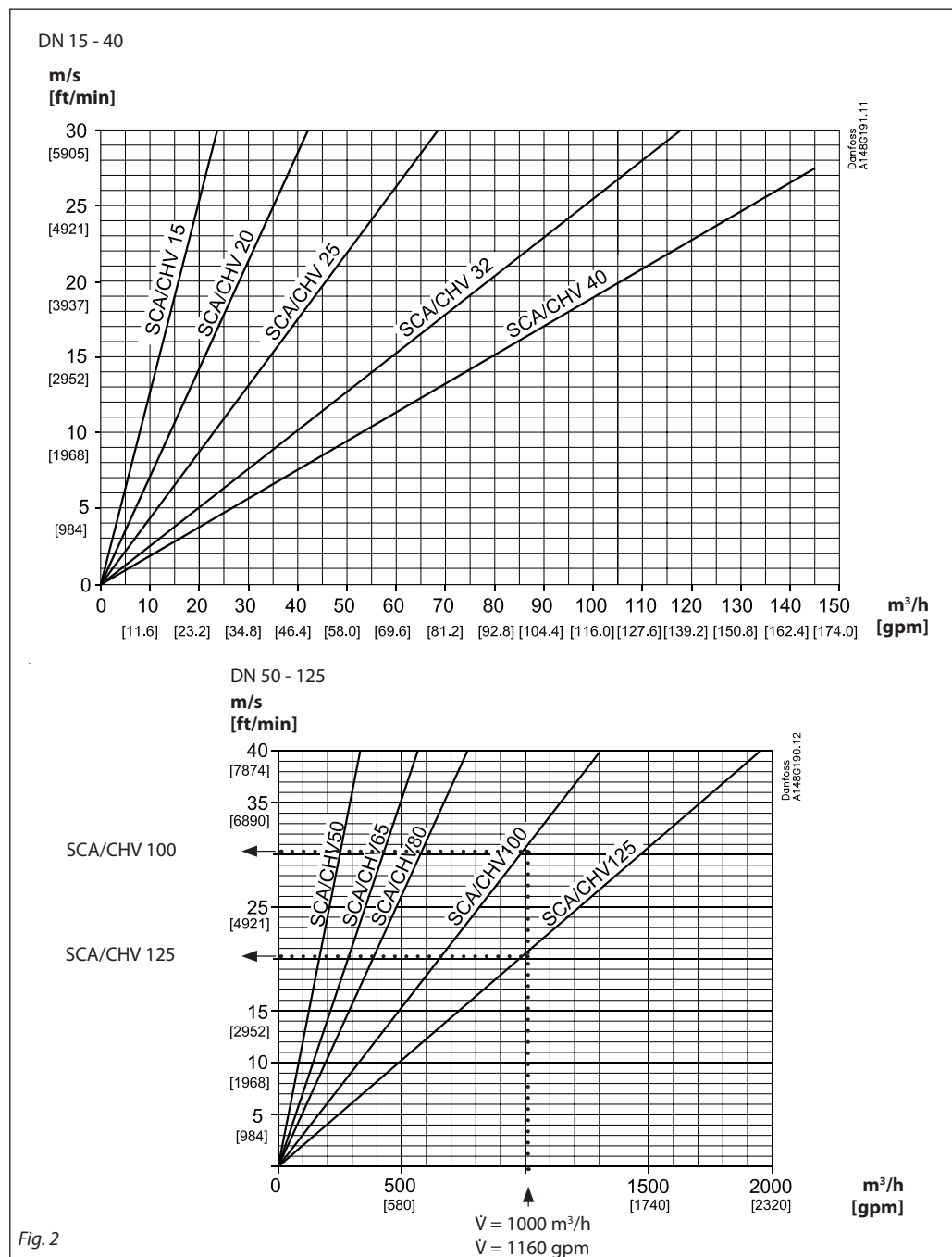
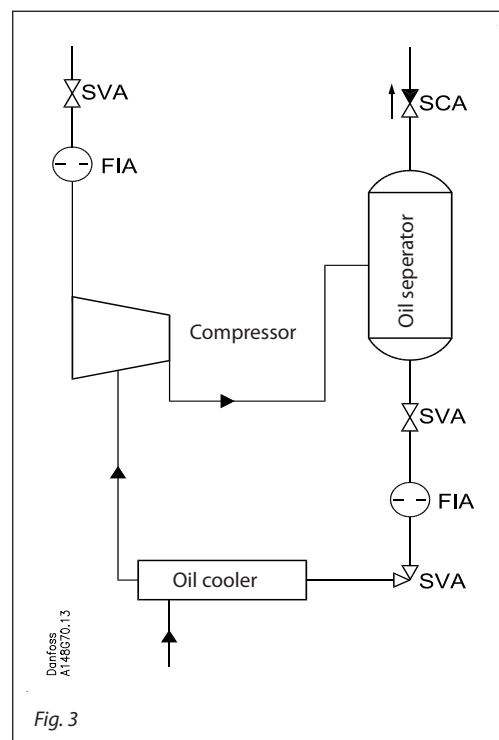

Fig. 2

Application

Figure 3 shows the stop/check valve SCA in the discharge line of a screw compressor unit. The SCA valve in the discharge line prevents "back condensation" in the oil separator as well as pressure equalising through the compressor. Compared to an ordinary stop and check valve arrangement, the combined stop/check valve solution, as shown is easier to install and has lower flow resistance.



Material specification

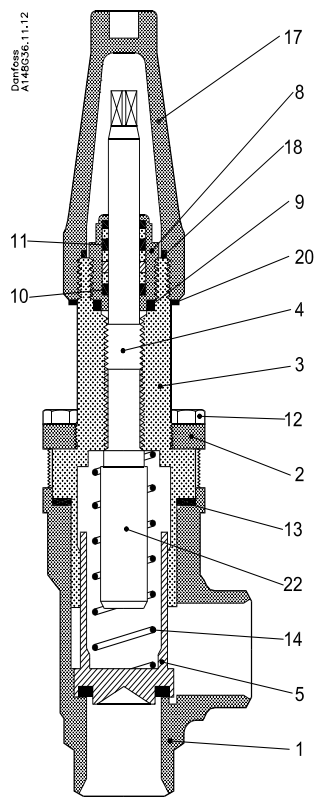

SCA 15 - 40

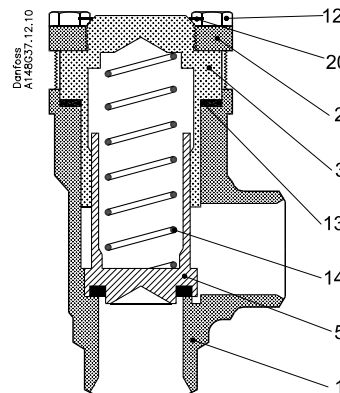

CHV 15 - 40

No.	Part	Material	DIN/EN	ISO	ASTM
1	Housing	Steel	P285QH EN10222-4		LF2A350
2	Bonnet, Flange	Steel	P275NL1 EN10028-3		
3	Bonnet, Insert	Steel			
4	Spindle	Stainless steel	X 10CrNiS18-9	Type 17, 17440	AISI 303, 683/13
5	Cone	Steel Teflon (PTFE)			
8	Packing gland O-rings	Steel Cloroprene (Neoprene)			
9	Packing washer	Aluminium			
12	Bolts	Stainless steel	A2-70	A2-70	Type 308
13	Gasket	Fiber, non-asbestos			
14	Spring	Steel			
17	Spindle seal cap	Aluminium			
18	Seal cap gasket	Nylon			
20	Identification ring	Stainless steel			
22	Spindle extension	Steel			

Material specification

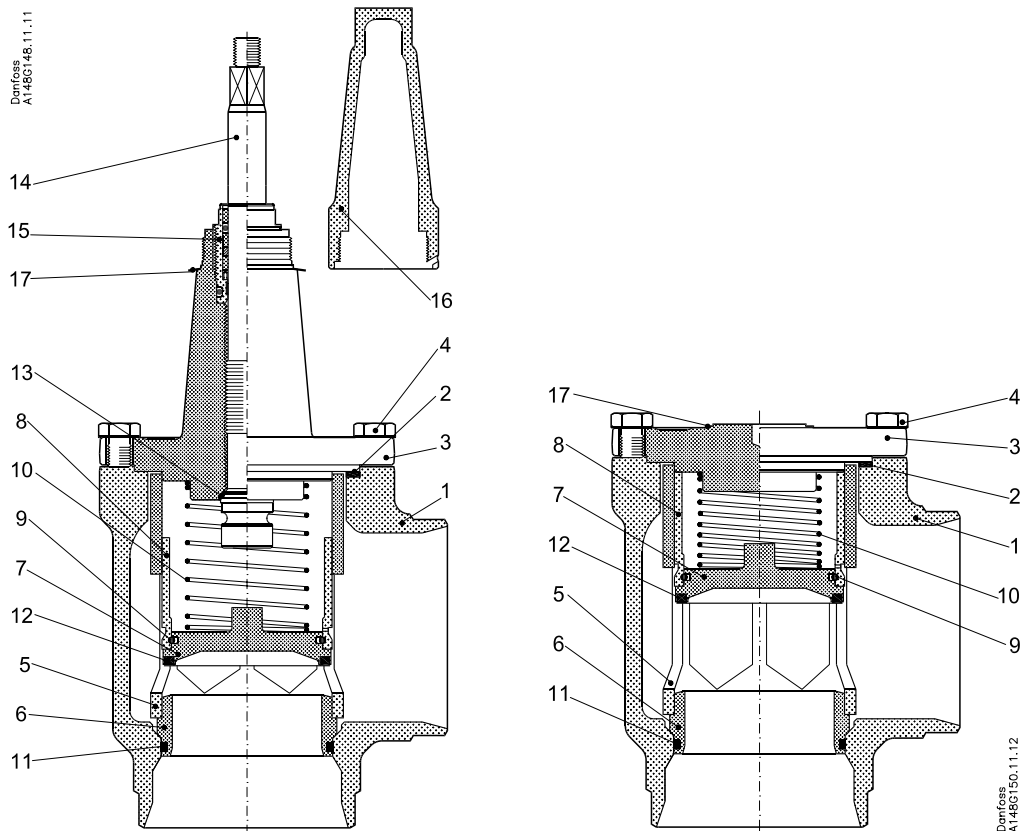

SCA 50 - 125

CHV 50 - 125

No.	Part	Material	DIN/EN	ISO	ASTM
1	Housing DN 50-65	Steel	P285 QH EN 10222-4		LF2A350
	Housing DN 80-125	Steel	G20Mn5 QT SEW 685		LCC, A352
2	Gasket	Fiber, Non-asbestos			
3	SCA: Valve bonnet CHV: End cover	Steel	P285 QH EN 10222-4		LF2A350
4	Bolts	Stainless steel	A2-70	A2-70	A-276
5	Tube	Steel			
6	Seat	Steel			
7	Valve plate	Steel			
8	Guide sleeve	Steel			
9	Spring ring	Steel			
10	Spring	Steel			
11	O-ring	Cloroprene (Neoprene)			
12	Teflon ring	Teflon (PTFE)			
13	Soft back seal	Teflon (PTFE)			
14	Spindle DN 50-65	Stainless steel	X8CrNi18-9 17440	Type 17 R 683/13	AISI 303
	Spindle DN 80-125	Stainless steel	X5CrNi1810 17440	Type 11 683/13	AISI 304 A-276
15	Packing gland	Steel	9Mn28, 1651	Type 2, R 683/9	1213, SAE J403
16	Spindle seal cap and gasket	Aluminium			
17	Marking label	Stainless steel			

Connections

Size mm	Size in.	OD mm	T mm	OD in.	T in.			k_v -angle m ³ /h		C_v -angle USgal/min	
---------	----------	-------	------	--------	-------	--	--	--------------------------------	--	------------------------	--

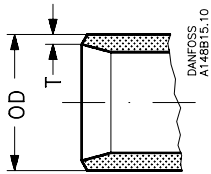
DIN

Welding DIN (2448)

15	½	21.3	2.3	0.839	0.091			8.0		9.3	
20	¾	26.9	2.3	1.059	0.091			10.0		11.6	
25	1	33.7	2.6	1.327	0.102			24.0		27.8	
32	1¼	42.4	2.6	1.669	0.102			30.0		34.8	
40	1½	48.3	2.6	1.902	0.102			30.0		34.8	

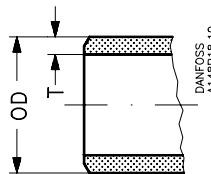
50	2	60.3	2.9	2.37	0.11			45		53	
65	2½	76.1	2.9	3.00	0.11			72		85	
80	3	88.9	3.2	3.50	0.13			103		129	
100	4	114.3	3.6	4.50	0.14			196		232	
125	5	139.7	4.0	5.50	0.16			301		356	

ANSI

Welding ANSI (B 36.10 Schedule 80)

15	½	21.3	3.7	0.839	0.146			8.0		9.3	
20	¾	26.9	4.0	1.059	0.158			10.0		11.6	
25	1	33.7	4.6	1.327	0.181			24.0		27.8	
32	1¼	42.4	4.9	1.669	0.193			30.0		34.8	
40	1½	48.3	5.1	1.902	0.201			30.0		34.8	

Welding ANSI (B 36.10 Schedule 40)

50	2	60.3	3.9	2.37	0.15			45		53	
65	2½	73.0	5.2	2.87	0.20			72		85	
80	3	88.9	5.5	3.50	0.22			103		129	
100	4	114.3	6.0	4.50	0.24			196		232	
125	5	141.3	6.6	5.56	0.26			301		356	

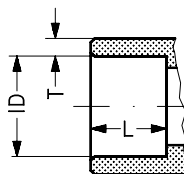
Size mm	Size in.	ID mm	T mm	ID in.	T in.	L mm	L in.	k_v -angle m ³ /h		C_v -angle USgal/min	
---------	----------	-------	------	--------	-------	------	-------	--------------------------------	--	------------------------	--

SOC

Socket welding ANSI (B 16.11)

50	2	61.2	6.2	2.41	0.24	16	0.63	80		93	
----	---	------	-----	------	------	----	------	----	--	----	--

Dimensions and weights

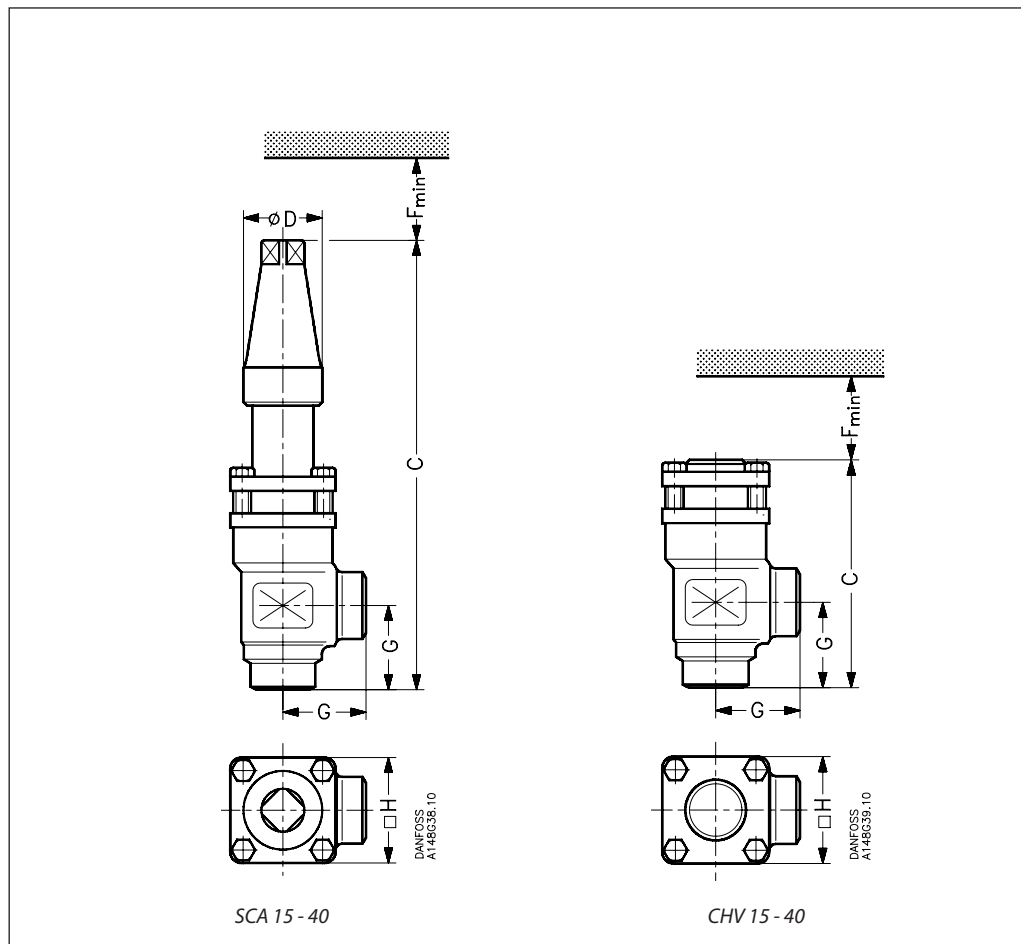
SCA/CHV 15 - 40 (½- 1½ in.)



Valve size		C	G	ØD	F _{min}	□H	Weight
------------	--	---	---	----	------------------	----	--------

SCA 15 - 40

SCA 15 (½ in.)	mm in.	212 8.35	45 1.77	38 1.50	60 2.36	60 2.36	1.6 kg
SCA 20 (¾ in.)	mm in.	212 8.35	45 1.77	38 1.50	60 2.36	60 2.36	1.6 kg
SCA 25 (1 in.)	mm in.	295 11.61	55 2.17	50 1.97	85 3.35	70 2.76	3.2 kg
SCA 32 (1¼ in.)	mm in.	295 11.61	55 2.17	50 1.97	85 3.35	70 2.76	3.2 kg
SCA 40 (1½ in.)	mm in.	295 11.61	55 2.17	50 1.97	85 3.35	70 2.76	3.2 kg

Valve size		C	G	F _{min}	□H	Weight
------------	--	---	---	------------------	----	--------

CHV 15 - 40

CHV 15 (½ in.)	mm in.	103 4.06	45 1.77	60 2.36	60 2.36	1.2 kg
CHV 20 (¾ in.)	mm in.	103 4.06	45 1.77	60 2.36	60 2.36	1.2 kg
CHV 25 (1 in.)	mm in.	143 5.63	55 2.17	85 3.35	70 2.76	2.3 kg
CHV 32 (1¼ in.)	mm in.	143 5.63	55 2.17	85 3.35	70 2.76	2.3 kg
CHV 40 (1½ in.)	mm in.	143 5.63	55 2.17	85 3.35	70 2.76	2.3 kg

Specified weights are approximate values only.

Dimensions and weights

SCA/CHV 50 - 65 (2 - 2½ in.)

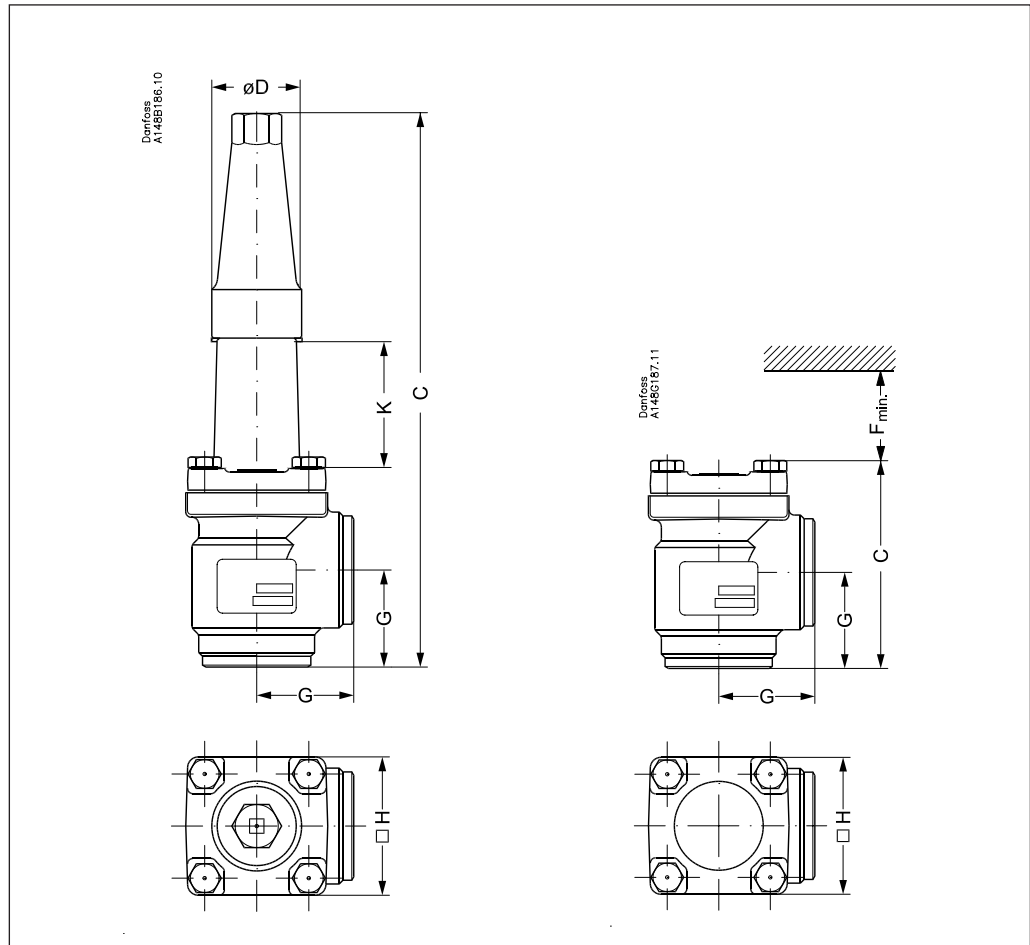

Valve size	K			C		G		ØD	□H		Weight
------------	---	--	--	---	--	---	--	----	----	--	--------

SCA

SCA 50	mm	70		315		60		50	77		3.8 kg
SCA (2)	in.	2.76		12.40		2.36		1.97	3.03		8.40 lb
SCA 65	mm	70		335		70		50	90		5.5 kg
SCA (2½)	in.	2.76	12.20	13.19		2.76	3.94	1.97	3.54		12.16 lb

Valve size				C		G		F _{min.}	□H		Weight
------------	--	--	--	---	--	---	--	-------------------	----	--	--------

CHV

CHV 50	mm			132		60		92	77		3.2 kg
CHV (2)	in.			5.20		2.36		3.62	3.03		7.10 lb
CHV 65	mm			152		70		107	90		4.5 kg
CHV (2½)	in.			5.98		2.76		4.21	3.54		9.95 lb

Specified weights are approximate values only.

Dimensions and weights

SCA/CHV 80 - 125 (3 - 5 in.)

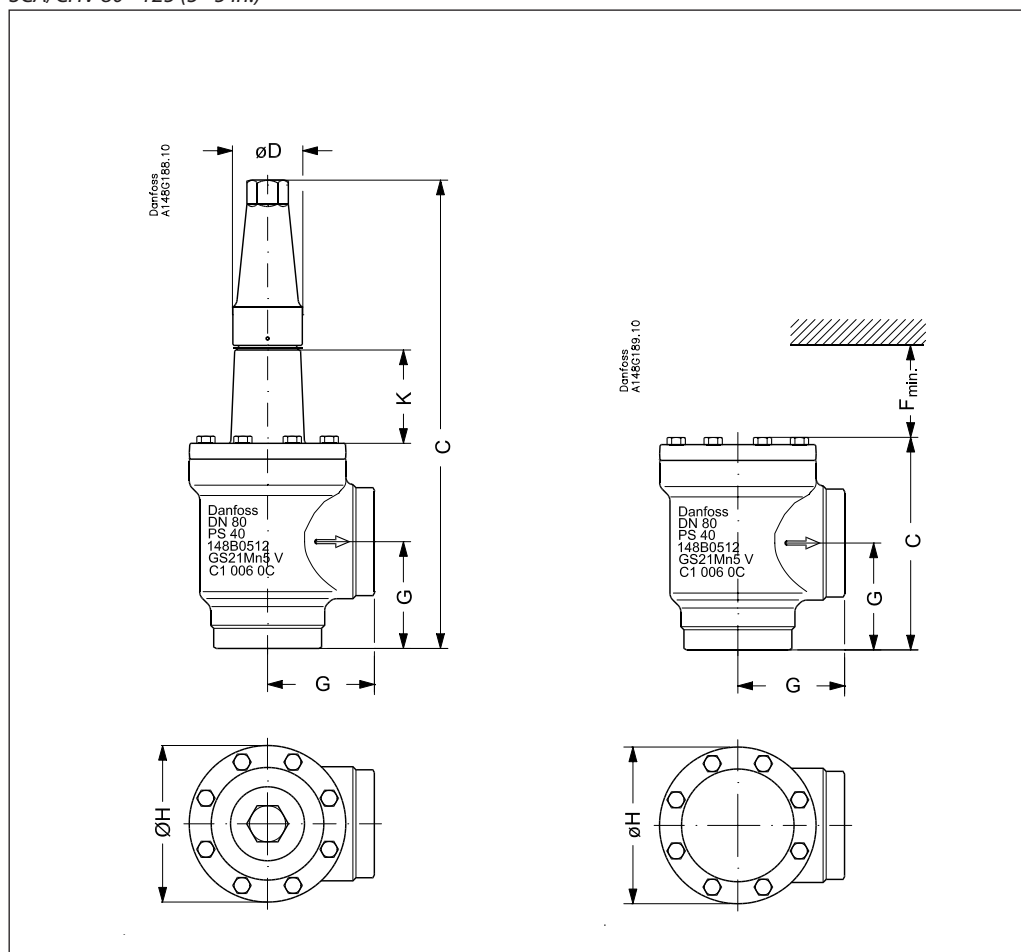

Valve size	K		C	G	ØD	ØH	Weight
------------	---	--	---	---	----	----	--------

SCA

SCA 80	mm	76		388	90	58	129	9.7 kg
SCA (3)	in.	3.00		15.28	3.54	2.28	5.08	21.4 lb
SCA 100	mm	90		437	106	58	156	15.3 kg
SCA (4)	in.	3.54		17.20	4.17	2.28	6.14	33.7 lb
SCA125	mm	90		533	128	74	193	28.1 kg
SCA (5)	in.	3.54		20.98	5.04	2.91	7.60	61.9 lb

Valve size			C	G	F _{min.}	ØH	Weight
------------	--	--	---	---	-------------------	----	--------

CHV

CHV 80	mm		189	90	133	129	8.7 kg
CHV (3)	in.		7.44	3.54	5.24	5.08	19.23 lb
CHV 100	mm		223	106	163	156	14.3 kg
CHV(4)	in.		8.78	4.17	6.43	6.14	31.60 lb
CHV125	mm		268	128	190	193	25.6 kg
CHV(5)	in.		10.55	5.04	7.48	7.60	56.58 lb

Specified weights are approximate values only.

Ordering
How to order

The table below is used to identify the valve required.

For further information please contact your local Danfoss Sales Company.

Please note that the type codes only serve to identify the valves, some of which may not form part of the standard product range.

Valve type	SCA CHV	Stop Check Valve Check Valve			
		ANSI	DIN	SOC	
(valve size measured on the connection diameter)	15	DN 15	x	x	
	20	DN 20	x	x	
	25	DN 25	x	x	
	32	DN 32	x	x	
	40	DN 40	x	x	
	50	DN 50	x	x	x
	65	DN 65	x	x	
	80	DN 80	x	x	
	100	DN 100	x	x	
	125	DN 125	x	x	
Connections	A	Welding branches: ANSI B 31.5 schedule 80 DN 15 - 40 (½ - 1½ in.)			
	D	Welding branches: ANSI B 31.5 schedule 40 DN 50 - 125 (2 - 5 in.)			
		Welding branches: DIN 2448			
Valve housing	ANG	Angle flow			

Important!

Where products need to be certified according to specific certification societies, or where higher pressures are required, the relevant information should be included at the time of order.

CHV, butt-weld DIN

Size		Type	Code No.
mm	in.		
15	½	CHV 15 D ANG	148G3072
20	¾	CHV 20 D ANG	148G3074
25	1	CHV 25 D ANG	148G3080
32	1¼	CHV 32 D ANG	148G3082
40	1½	CHV 40 D ANG	148G3084
50	2	CHV 50 D ANG	148G3129
65	2½	CHV 65 D ANG	148G3130
80	3	CHV 80 D ANG	148G3131
100	4	CHV 100 D ANG	148G3132
125	5	CHV 125 D ANG	148G3133

SCA, butt-weld DIN

Size		Type	Code No.
mm	in.		
15	½	SCA 15 D ANG	148G3076
20	¾	SCA 20 D ANG	148G3078
25	1	SCA 25 D ANG	148G3086
32	1¼	SCA 32 D ANG	148G3088
40	1½	SCA 40 D ANG	148G3090
50	2	SCA 50 D ANG	148G3134
65	2½	SCA 65 D ANG	148G3135
80	3	SCA 80 D ANG	148G3136
100	4	SCA 100 D ANG	148G3137
125	5	SCA 125 D ANG	148G3138

CHV, butt-weld ANSI

Size		Type	Code No.
mm	in.		
15	½	CHV 15 A ANG	148G3073
20	¾	CHV 20 A ANG	148G3075
25	1	CHV 25 A ANG	148G3081
32	1¼	CHV 32 A ANG	148G3083
40	1½	CHV 40 A ANG	148G3085
50	2	CHV 50 A ANG	148G3139
65	2½	CHV 65 A ANG	148G3140
80	3	CHV 80 A ANG	148G3141
100	4	CHV 100 A ANG	148G3142
125	5	CHV 125 A ANG	148G3143

SCA, butt-weld ANSI

Size		Type	Code No.
mm	in.		
15	½	SCA 15 A ANG	148G3077
20	¾	SCA 20 A ANG	148G3079
25	1	SCA 25 A ANG	148G3087
32	1¼	SCA 32 A ANG	148G3089
40	1½	SCA 40 A ANG	148G3091
50	2	SCA 50 A ANG	148G3144
65	2½	SCA 65 A ANG	148G3145
80	3	SCA 80 A ANG	148G3146
100	4	SCA 100 A ANG	148G3147
125	5	SCA 125 A ANG	148G3148

CHV, socket weld SOC

Size		Type	Code No.
mm	in.		
50	2	CHV 50 SOC ANG	148G3149

SCA, socket weld SOC

Size		Type	Code No.
mm	in.		
50	2	SCA 50 SOC ANG	148G3150

