



Safety relief valves, type SFA 15

Contents

	Page
Introduction.....	3
Features.....	3
Technical data.....	4
Design.....	5
Capacity.....	6
Material specification.....	8
Connections.....	9
Dimensions and weights.....	9
Ordering.....	10

Introduction



SFA 15 are standard, **back pressure dependent** safety relief valves in angle-way execution, specially designed for protection of vessels and other components against excessive pressure.

The valve is designed to meet the strict quality demands and safety requirements for refrigeration installations, specified by the international classification societies.

The valve is recommended as an external and internal safety relief valve in refrigeration plants. The spring housing is closed tightly to avoid refrigerant leakage.

The inlet flow diameters of the valves are:
- 13 mm (½ in.) for SFA 15

The valves can be delivered with set pressures between 10 and 40 bar g (145 and 580 psi g).

Standard pressure setting valves having "TÜV Pressure Setting Certificate" with each valve, are also available.

Features

- Applicable for the refrigerants R717 (ammonia, NH₃), HFC, HCFC (e.g. R22, R134a, R404A) and other refrigerants (dependent on sealing materials compatibility) within a temperature range of -30°C/+100°C (-22°F/+212°F).
- Classification: To get an updated list of certification on the products please contact your local Danfoss Sales Company.

Technical data

- Refrigerants
Applicable for the refrigerants R717 (ammonia, NH₃), HFC, HCFC (e.g. R22, R134a, R404A) and other refrigerants dependent on sealing material compatibility within a temperature range of -30°C/+100°C (-22°F/+212°F). Flammable hydrocarbons are not recommended. For further information please contact your local Danfoss Sales Company.
- Pressure
Pressure setting range: 10 - 40 bar g (145 - 580 psi g). For further information please contact your local Danfoss Sales Company.
- Pressure setting
The operating pressure of the plant should be at least 15% below the set pressure. This allows a perfect re-seating of the safety relief valve after having been activated.
- Temperature range
-30/+100°C (-22/+212°F)

Important: The SFA safety relief valve is dependent on the back pressure (if the back pressure is higher than the atmospheric pressure, the opening pressure will be higher than stated set pressure).
Special circumstances such as vibrations (which should be avoided) and oscillating pressure may require an increased difference between the operational pressure and the closing pressure.

Pressure Equipment Directive (PED)
The SFA valves are approved in accordance with the European standard specified in the Pressure Equipment Directive and are CE marked.
For further details / restrictions - see Installation Instruction



SFA valves	
Nominal bore	13 mm (0.512 in.)
Classified for	Fluid group I
Category	IV

Design

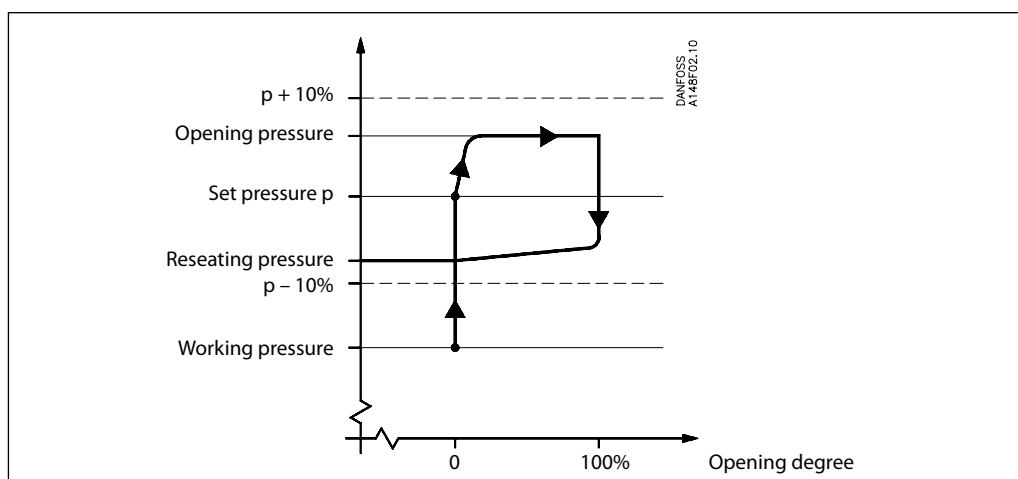

SFA is designed as a **standard safety relief valve** (DIN 3320), which is recommended for refrigeration plants. On a rise in pressure above the set pressure, the safety relief valve will initially start opening slightly, to minimise the outlet of

refrigerant. If the pressure continues to increase, the valve will open fully. The safety relief valve will be fully open before the pressure is 10% higher than set pressure, and fully closed before the pressure is 10% below set pressure.

Connections

Available with the following connections:

- Outside pipe thread T (ISO 228/1)
- Welding fittings (DIN 2448)

Housing

Made of special steel approved for low temperature operation. Spindle, cone, and seat are made of stainless steel, to ensure precise operation even during extraordinary conditions. The gasket of the valve cone is made of a special chloroprene (neoprene) compound.

Installation

To ensure exact operation of the safety relief valve it should be installed with the spring housing upwards. If the valve is mounted as an internal safety relief valve without any demand for exact opening pressure, the valve may be fitted with the spring housing in other positions. When the valve is mounted, it is important to avoid the influence of static, dynamic and thermal stress.

A very precise technique has been applied for the production of the seal. However, this seal can still be damaged, if dirt is blown from the pipe system into the valve.

It is recommended that safety relief valves exhaust into the open air with a U-pipe filled with oil on the discharge branch, to prevent dirt from penetrating into the valve. It is also recommended that the valves be installed in pairs in conjunction with the double stop valve type DSV 1 or 2. For further information please see the technical leaflet for DSV.

Re-calibration/servicing

In certain countries the authorities demand that the valves are readjusted at least once a year (see local rules).

Control/Identification

After adjustment of the set pressure at Danfoss, the valves are sealed. For that reason Danfoss can only guarantee correct operation, as long as the seal remains unbroken.

All valves are provided with a metal plate with the following information:

- Flow diameter
- Set pressure
- Date of production
- Production number
- Type approved code.

Transport/Handling

The valves are fitted with special protection covers and packed into purpose made transportation cartons.

It is important that the cover remains fitted around the valve until it is installed.

To ensure the exact and precise operation of the valve it must be handled with care.

Safety valve	Double stop valve		Max. pressure
	CE marked	Not CE marked	
SFA 15	DSV 1		40 bar (580 psi)
	DSV 2		40 bar (580 psi)
		DSV 15	25 bar (363 psi)

Capacity

The design and construction of the safety relief valve has been tested and approved by TÜV. This test comprises control of the function of the valve as well as measuring of the capacity, which is the basis of the curves and tables on the following pages. The values in the table are based on saturated gas.

If e.g. back pressure or superheated gas have to be taken into consideration, the formulas or the Danfoss computation program (DIRcalc™) can be used.

Table 1.

Valve	Nominal size		Flow diameter d_o	Flow area A_0	De-rated, certified coefficient of discharge K_{dr}
	Inlet	Outlet			
SFA 15	15 mm	20 mm	13 mm	133 mm ²	0.73
	½ in.	¾ in.	0.512 in.	0.206 in ²	

The discharge capacity of the safety relief valves are based on (ISO 4126-1/EN 1268-1 / prEN 1313 6 (1998)).

$$q_m = 0.2883 \times C \times A_0 \times K_{dr} \times K_b \sqrt{v}$$

q_m Discharge capacity (kg/h).

C Discharge function depending of the actual refrigerant (κ) see table 2 (-).

A_0 Flow area of the safety relief valve (mm²).

K_{dr} De-rated coefficient of discharge ($K_{dr} = K_d \times 0.9$), (the K_{dr} is certified by TÜV) see table 1 (-).

K_b Correction factor for sub-critical flow (-).

$K_b = 1.0$ when the back pressure is lower than approx. $0.5 \times$ relieving pressure ($P_b < 0.5 \times p$).

For all SFV safety valves $K_b = 1.0$

v Specific volume of the vapour at the relieving pressure p . (m³/kg).

p_{set} Set pressure, the predetermined pressure at which a pressure relief valve under operation starts to open (p_{set} is indicated on the metal plate on the safety relief valve).
(bar gauge)

p_{atm} Atmospheric pressure (1 bar).

p Relieving pressure, $p = p_{set} \times 1.1 + P_{atm}$ (bar absolute).

For further details see the above-mentioned ISO or EN standards.

Table 2. Properties of refrigerants

Refrigerant	Isentropic exponent κ	Discharge function C
R22	1.17	2.54
R134a	1.12	2.50
R404A	1.12	2.49
R410A	1.17	2.54
R717 (Ammonia)	1.31	2.64
R744 (CO ₂)	1.30	2.63
Air	1.40	2.70

Capacity

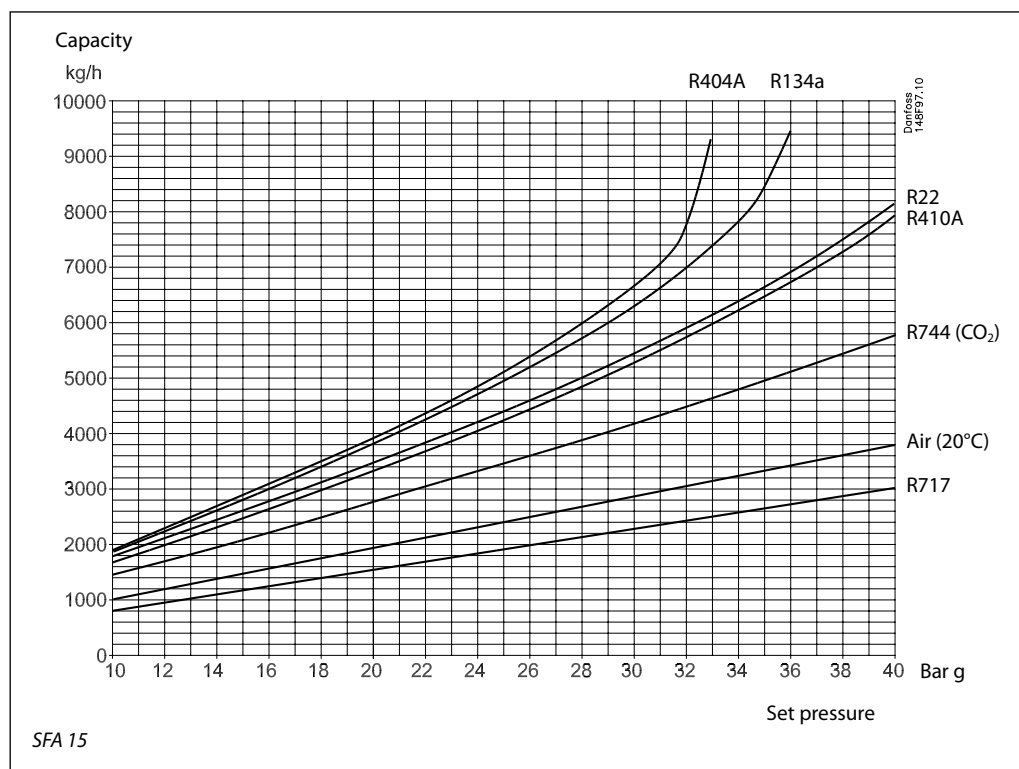

Capacity

Set pressure	qm	R22	R134a	R404A	R410A	R717	R744 (CO ₂)	Air (20°C)
SFA 15								
10 bar g	kg/h	1749	1881	1888	1652	779	1424	1003
145 psi g	lb/min	64	69	69	61	29	52	37
15 bar g	kg/h	2592	2793	2842	2459	1135	2072	1462
218 psi g	lb/min	95	103	104	90	42	76	54
20 bar g	kg/h	3471	3804	3883	3305	1492	2747	1922
290 psi g	lb/min	128	140	143	121	55	101	71
25 bar g	kg/h	4409	4921	5101	4248	1853	3441	2381
363 psi g	lb/min	162	181	187	156	68	126	87
30 bar g	kg/h	5437	6269	6659	5250	2227	4163	2841
435 psi g	lb/min	200	230	245	193	82	153	104
35 bar g	kg/h	6633	8370		6450	2608	4936	3301
508 psi g	lb/min	244	308		237	96	181	121
40 bar g	kg/h	8104			7911	2989	5718	3760
580 psi g	lb/min	298			291	110	210	138

Material specification

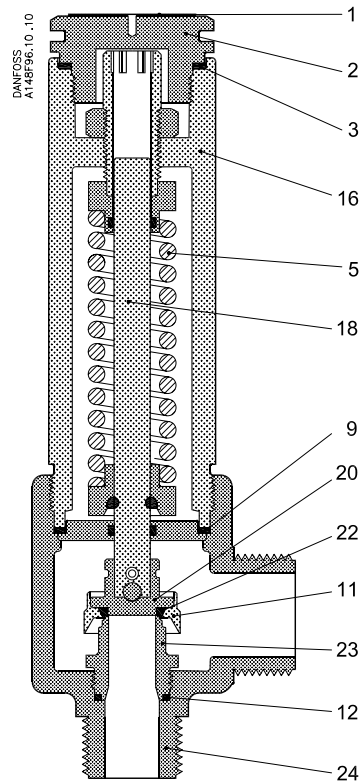

No.	Part	Material	DIN	ISO	ASTM
1	Marking label	Stainless steel			
2	Threaded plug	Steel			
3	Packing washer	Aluminium (Non-asbestos gasket)			
5	Spring	Steel	Class C, DIN17223		
9	Packing washer	Aluminium (Non-asbestos gasket)			
11	Retainer	Stainless steel	X8CrNiS 18 9		AISI 303, A276
12	Packing washer	Aluminium (Non-asbestos gasket)			
16	Valve top	Steel	G20Mn5QT Alt. S235JRG2 Alt. S355J2G3	Fe360BFN Fe510D1	LCC, A352 A284C A572-50
18	Valve spindle	Stainless steel	X5CrNi 18 10		AISI 304, A276
20	Valve cone	Stainless steel	X8CrNiS 18 9		AISI 303, A276
22	Valve cone seal	Cloroprene (Neoprene)			
23	Valve seat	Stainless steel	X8CrNiS 18 9		AISI 303, A276
24	Valve housing	Steel	G20Mn5QT Alt. P285QH		LCC, A352 LF2, A350

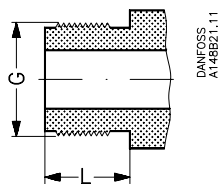
Connections
T

Size mm	Size in.	Inlet	Outlet				L mm	L in.	
<i>T outside pipe thread, (ISO 228/1)</i>									
15	½	G ¾	G 1				15	0.59	

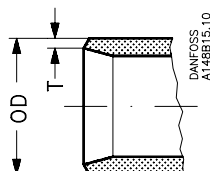
DIN

Size mm	Size in.	Inlet (mm)		Inlet (in.)		Outlet (mm)		Outlet (in.)	
		OD	T	OD	T	OD	T	OD	T
<i>Welding fittings, DIN (2448)</i>									
15	½	21.3	2.3	0.839	0.091	26.9	2.3	1.059	0.091

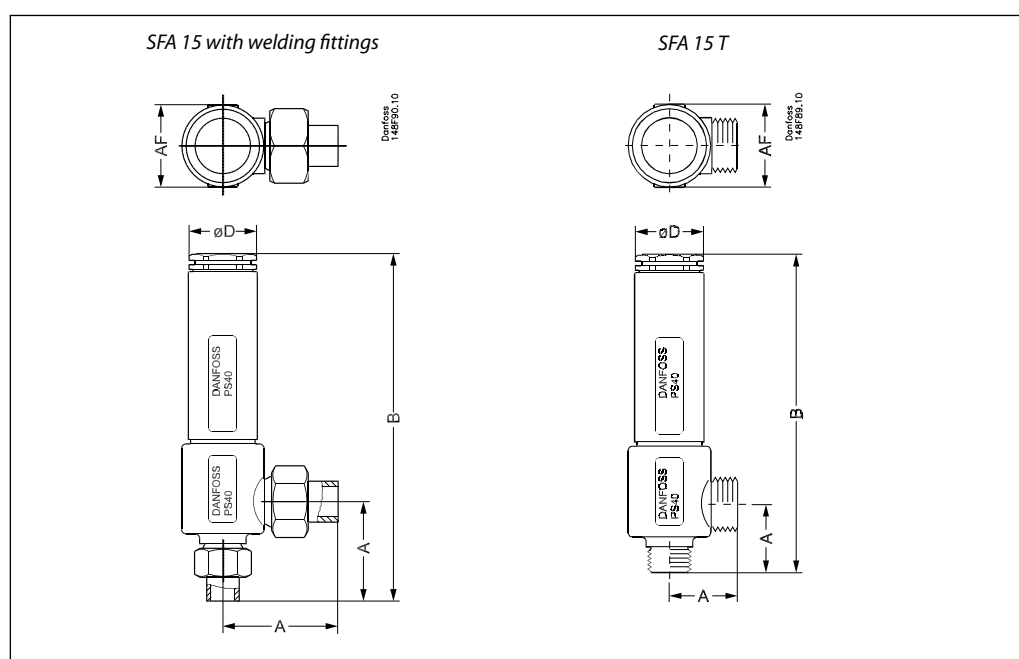
Dimensions and weights

Valve size		A	B	ØD	AF	Weight
<i>SFA 15 T, with threaded connections ISO 228/1 pipe threads</i>						
SFA 15	mm	45	210	45	55	2.2 kg
(½ in.)	in.	1.77	8.27	1.81	2.17	4.9 lbs
<i>SFA with welding fittings, DIN 2448</i>						
SFA 15	mm	83	248	45	55	2.5 kg
(½ in.)	in.	3.27	9.76	1.81	2.17	5.5 lbs

Specified weights are approximate values only.

Ordering
Certified SFA valves with standard set pressure

Size		Type	Set pressure bar g (psi g)	Code number
mm	in.			
15	½	SFA 15 T 210	10 (145)	148F3210
15	½	SFA 15 T 211	11 (160)	148F3211
15	½	SFA 15 T 212	12 (174)	148F3212
15	½	SFA 15 T 213	13 (189)	148F3213
15	½	SFA 15 T 214	14 (203)	148F3214
15	½	SFA 15 T 215	15 (218)	148F3215
15	½	SFA 15 T 216	16 (232)	148F3216
15	½	SFA 15 T 217	17 (247)	148F3217
15	½	SFA 15 T 218	18 (261)	148F3218
15	½	SFA 15 T 219	19 (276)	148F3219
15	½	SFA 15 T 220	20 (290)	148F3220
15	½	SFA 15 T 221	21 (305)	148F3221
15	½	SFA 15 T 222	22 (319)	148F3222
15	½	SFA 15 T 223	23 (334)	148F3223
15	½	SFA 15 T 224	24 (348)	148F3224
15	½	SFA 15 T 225	25 (363)	148F3225
15	½	SFA 15 T 226	26 (377)	148F3226
15	½	SFA 15 T 227	27 (392)	148F3227
15	½	SFA 15 T 228	28 (406)	148F3228
15	½	SFA 15 T 229	29 (421)	148F3229
15	½	SFA 15 T 230	30 (435)	148F3230
15	½	SFA 15 T 231	31 (450)	148F3231
15	½	SFA 15 T 232	32 (464)	148F3232
15	½	SFA 15 T 233	33 (479)	148F3233
15	½	SFA 15 T 234	34 (493)	148F3234
15	½	SFA 15 T 235	35 (508)	148F3235
15	½	SFA 15 T 236	36 (522)	148F3236
15	½	SFA 15 T 237	37 (537)	148F3237
15	½	SFA 15 T 238	38 (551)	148F3238
15	½	SFA 15 T 239	39 (566)	148F3239
15	½	SFA 15 T 240	40 (580)	148F3240

Certified SFA valves with standard set pressure and TÜV pressure setting certificate with each valve

Size		Type	Set pressure bar g (psi g)	Code number
mm	in.			
15	½	SFA 15 T 310	10 (145)	148F3310
15	½	SFA 15 T 311	11 (160)	148F3311
15	½	SFA 15 T 312	12 (174)	148F3312
15	½	SFA 15 T 313	13 (189)	148F3313
15	½	SFA 15 T 314	14 (203)	148F3314
15	½	SFA 15 T 315	15 (218)	148F3315
15	½	SFA 15 T 316	16 (232)	148F3316
15	½	SFA 15 T 317	17 (247)	148F3317
15	½	SFA 15 T 318	18 (261)	148F3318
15	½	SFA 15 T 319	19 (276)	148F3319
15	½	SFA 15 T 320	20 (290)	148F3320
15	½	SFA 15 T 321	21 (305)	148F3321
15	½	SFA 15 T 322	22 (319)	148F3322
15	½	SFA 15 T 323	23 (334)	148F3323
15	½	SFA 15 T 324	24 (348)	148F3324
15	½	SFA 15 T 325	25 (363)	148F3325
15	½	SFA 15 T 326	26 (377)	148F3326
15	½	SFA 15 T 327	27 (392)	148F3327
15	½	SFA 15 T 328	28 (406)	148F3328
15	½	SFA 15 T 329	29 (421)	148F3329
15	½	SFA 15 T 330	30 (435)	148F3330
15	½	SFA 15 T 331	31 (450)	148F3331
15	½	SFA 15 T 332	32 (464)	148F3332
15	½	SFA 15 T 333	33 (479)	148F3333
15	½	SFA 15 T 334	34 (493)	148F3334
15	½	SFA 15 T 335	35 (508)	148F3335
15	½	SFA 15 T 336	36 (522)	148F3336
15	½	SFA 15 T 337	37 (537)	148F3337
15	½	SFA 15 T 338	38 (551)	148F3338
15	½	SFA 15 T 339	39 (566)	148F3339
15	½	SFA 15 T 340	40 (580)	148F3340

Repair kit

Type	Code number
Repair kit SFA 15	148F3036

Nipples and gaskets

Type	Code number
Nipples + gaskets set for SFV 15/SFA 15	148F3019

