



Gas powered stop valves, type GPLX 80-150

Contents

	Page
Introduction.....	3
Features.....	3
Technical data.....	3
Design.....	4
Function.....	5
Wet suction line.....	6
Nominal capacities - R 717.....	8
Nominal capacities - R 22.....	9
Nominal capacities - R 404A.....	10
Dry suction line.....	11
Nominal capacities - R 717.....	13
Nominal capacities - R 22.....	14
Nominal capacities - R 134a.....	15
Nominal capacities - R 404A.....	16
Hot Gas Defrosting - Pump circulation systems (flooded evaporators).....	17
Material specification.....	18
Connections.....	20
Dimensions and weights.....	20
Ordering.....	21

Introduction

GPLX are automatic two step on/off normally closed (NC) valves. They are designed for hot gas defrosting, suction lines and other applications.

The valves have a built-in pressure equalising system preventing pressure shock and therefore eliminating the need for external bypass with resultant cost savings. GPLX are angle valves with weld connections.

Features

- Applicable to all common non flammable refrigerants including R 717 and non corrosive gases/liquids dependent on sealing material compatibility.
- Built-in pressure equalising system for prevention of pressure shock - no external bypass required.
- Angle valves with weld connections.
- $-60^{\circ}/+150^{\circ}\text{C}$ ($-76^{\circ}/+302^{\circ}\text{F}$).
- Housing and bonnet made from low temperature steel according to requirements of the Pressure Equipment Directive and other international classification authorities.
- Each valve is clearly marked with type, size and performance range.
- Stainless steel bolts.
- Max. operating pressure 40 bar g (580 psi g). Valves for higher operating pressure available on request.
- The valve cone has two teflon tightening rings with built-in metallic stops to prevent damage to the teflon rings in case of extreme pressure difference.
- Classification: To receive an updated list of certification on the products please contact your local Danfoss Sales Company.

Pressure Equipment Directive (PED)

The GPLX valves are approved and CE-marked in accordance with the Pressure Equipment Directive - 97/23/CE.

For further details / restrictions - see Installation Instruction.



GPLX valves		
Nominal bore	DN 80 mm (3 in.)	DN 100 - 150 mm (4-6 in.)
Classified for	Fluid group I	
Category	II	III

Technical data
Refrigerants

Applicable to all common non flammable refrigerants including R 717 and non corrosive gases/liquids dependent on sealing material compatibility. For further information please see installation instruction for GPLX. Flammable hydrocarbons are not recommended. For further information please contact your local Danfoss Sales Company.

Temperature Range
 $-60^{\circ}/+150^{\circ}\text{C}$ ($-76^{\circ}/+302^{\circ}\text{F}$).

Pressure

The valves are designed for:
 Max. working pressure: 40 bar g (580 psi g).
 Valves for higher working pressure are available on request.

Design

(See figure 1)

Standard sizes DN 80 - 150 (3 in. - 6 in.)
 GPLX are equipped with an extension on the top of the actuator (1) for manual opening of the valve.

Connections

Available with the following connections:
 Butt weld DIN (2448)
 Butt weld ANSI (B 36.10, schedule 40).

Housing and bonnet

Made of special cold resistant steel approved for low temperature operation.

Cone (10)

The valve cone has two teflon tightening rings (2 & 3), both with built-in metallic stops to prevent damage to the teflon rings in case of an extreme pressure difference.

Spindle (1)

Made of gas-tempered steel; consequently the valve spindle has an extremely hard and smooth surface.

Packing Glands

GPLX has no external packing glands. Internally, the valve is equipped with three packing glands of the O-ring type: One between the valve housing and the lower actuator chamber (4) and two between the lower and upper actuator chamber (5 & 6).

Actuator

The GPLX actuator has two chambers (A & B) separated by a piston (7).

The upper compartment has two springs. The inner spring (8) provides the second stage opening.

The function of the outer spring (9) is to close the inner teflon ring (3) of the valve cone. The outer spring also serves to force any possible condensate out of the lower actuator chamber, through the pilot valve assembly into the upper actuator chamber and from there into the suction side of the system.

The lower chamber (B) of the actuator is connected to the hot gas supply (P_2), which must be activated during the period when the main valve is open.

Installation

The actuator has one threaded ($G \frac{1}{4}$ in.) connection for mounting of the pilot valve.

Fittings for connection of steel pipe DN 8 ($d_o/d_i = 10/8$ mm) by means of cutting rings or welding nipples are supplied.

The installation of a FIL 6 filter accessory in the pilot line is recommended.

The valve is designed to resist very high internal pressure, but as to the pipe system in general, hydraulic pressure caused by thermal expansions in entrapped refrigerants should be avoided.

For further information please refer to GPLX installation instruction.

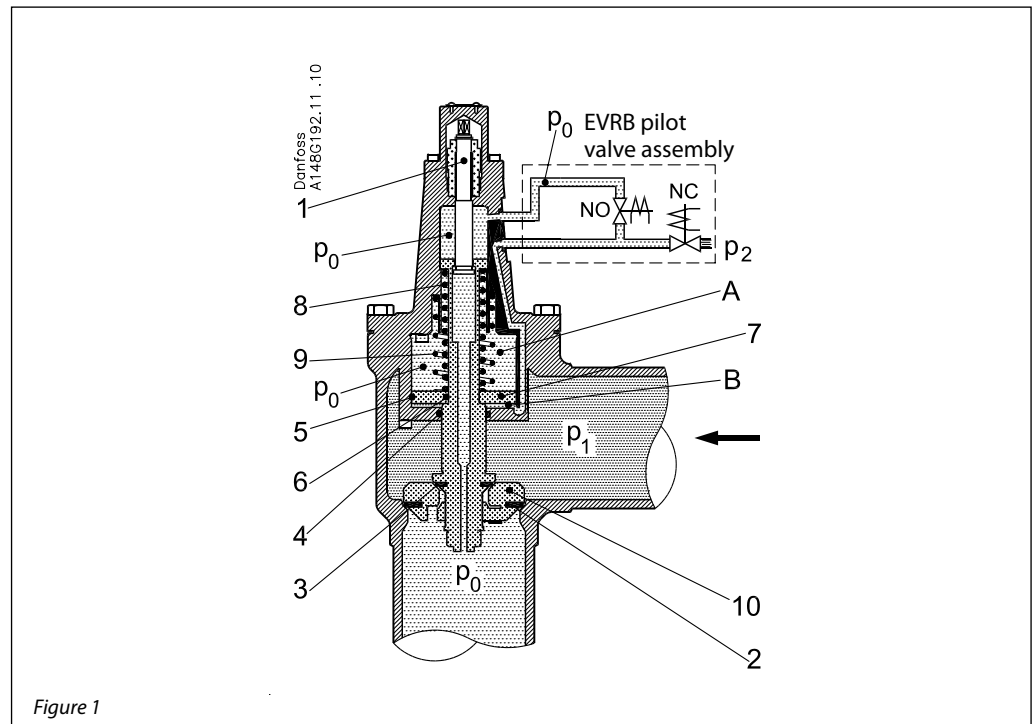

Figure 1

Function

(See figure 1 and 2)

The GPLX valve is of the Normally Closed-type (NC), i.e. in an unloaded condition the valve will always be closed. When the valve is closed, the channel through the spindle (1) is open so that the low pressure (P_0) will travel up through the channel to the top of the piston (7). The valve remains closed due to the force of the outer spring (9).

Furthermore, the pressure difference across the valve cone (10) ($P_1 > P_0$) will increase the closing force of the valve.

The valve is opened by allowing hot gas (P_2) into the chamber below the piston (7) by the EVRB pilot valve assembly, NC.

When the hot gas pressure (P_2) below the piston (7) has reached a level where it is able to overcome both the outer spring and the pressure difference across the valve cone (10) ($P_1 - P_0$), the spindle (1) will begin to move upwards against the spring force on the top of the piston (7), and the inner pilot seat (3) will open (**stage 1**).

If the hot gas pressure P_2 increases, it has no influence on **stage 2** pressure difference, because this pressure will only force the piston to move upwards and thereby compress both the outer and inner springs (8 & 9) and not allow **stage 2** opening before the pressure difference $P_1 - P_0$ is 1.5 bar. The reason for this is that the force for opening stage 2 comes from the compressed inner spring (9) and not P_2 .

When the inner pilot seat (3) is opened, the main valve pressure will begin to equalise (P_1 will be equalised to P_0), and furthermore, the channel through the spindle will feed the pressure P_1 to the top of the piston.

When the pressure equalisation across the valve seat is sufficient, the inner spring will be able to fully open the valve (**stage 2**).

The valve is closed by releasing the hot gas pressure from the chamber below the piston (7) and at the same time connecting it with the suction side P_0 . Then the force from the outer spring will close the valve.

To ensure smooth operation of the GPLX valve the following rules must be adhered to:

- $P_2 \geq P_0 + 3 \text{ bar g (43.5 p sig)}$ and
- $P_2 \geq P_1$ and
- $P_1 \leq 25 \text{ bar g (363 p sig)}$
- $P_1 - P_0 \leq 20 \text{ bar g (290.1 psi g)}$

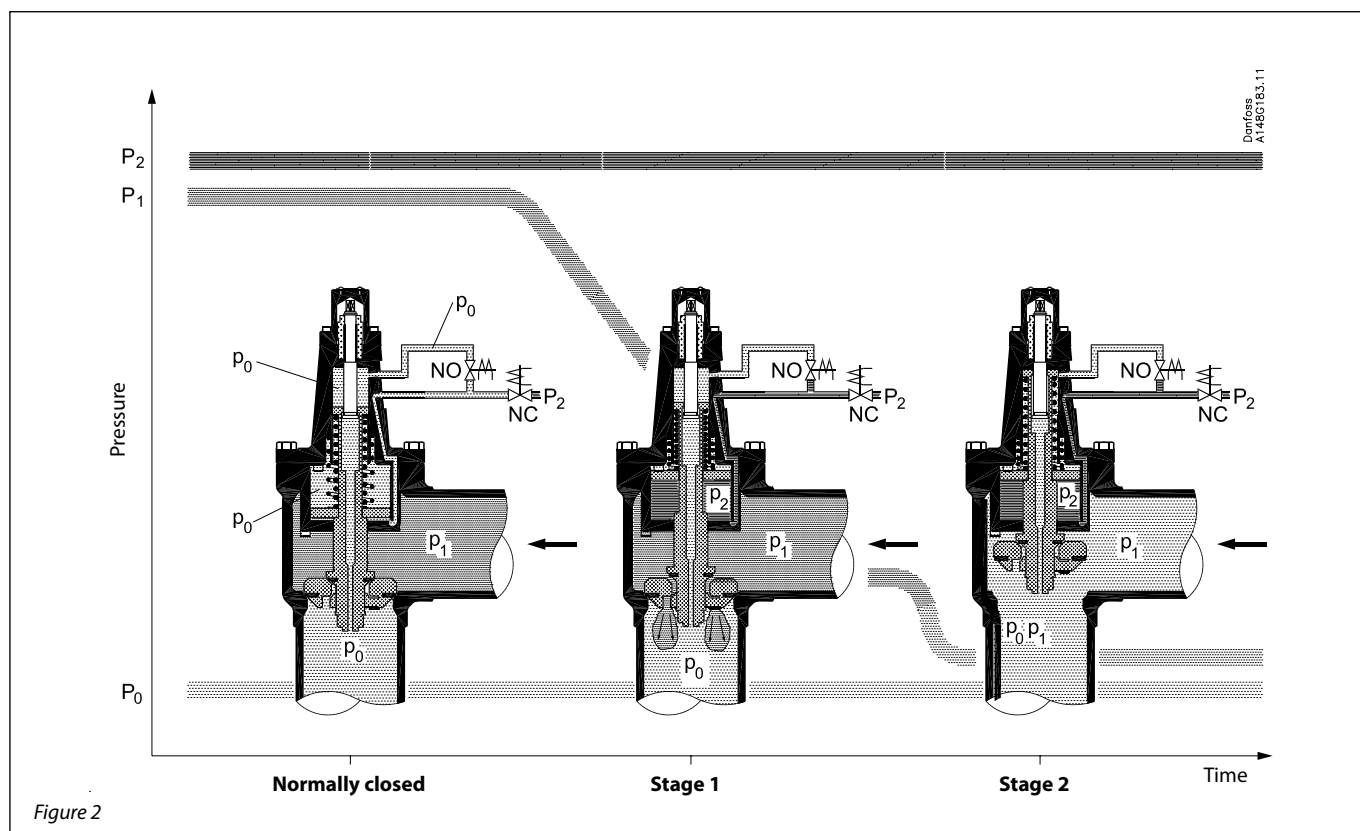
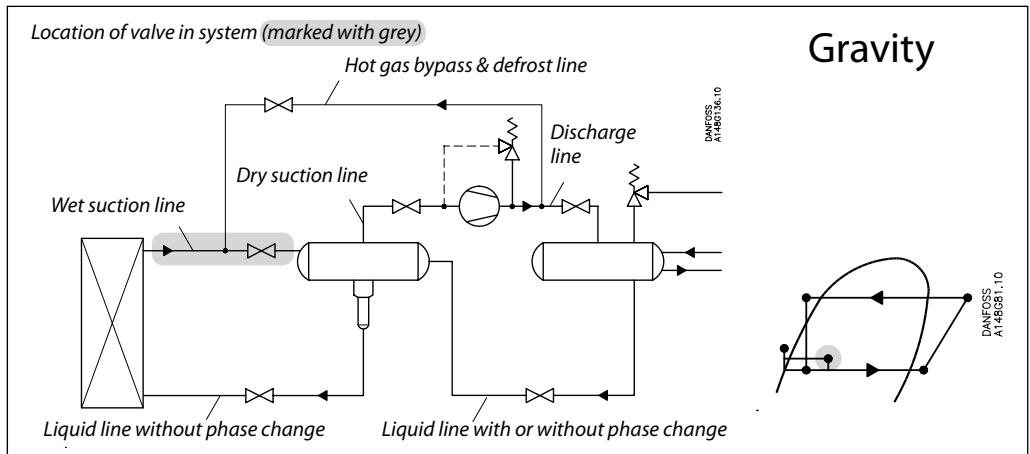
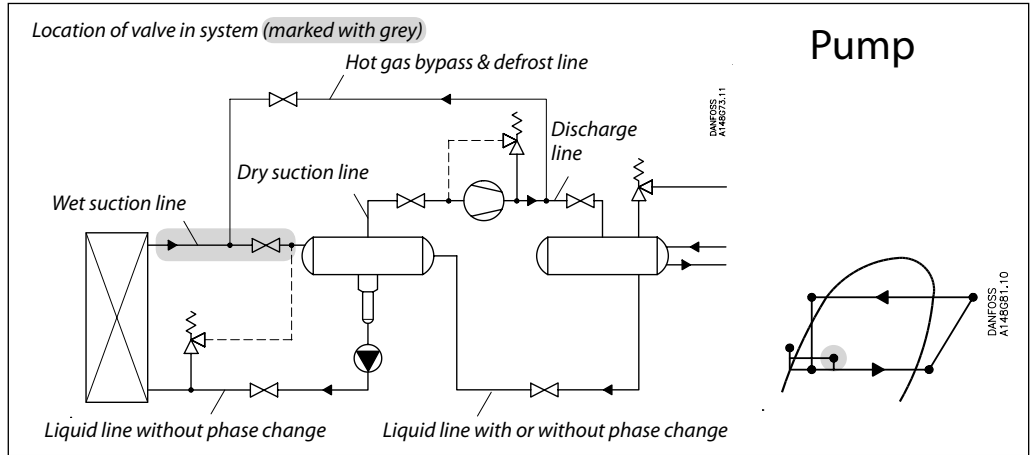

Figure 2

Nominal capacities

Wet suction line



Nominal capacities

Wet suction line

SI units

Calculation example (R 717 capacities):

An application has the following running conditions:

- $T_e = -35^\circ\text{C}$
- $Q_0 = 250 \text{ kW}$
- Recirculating rate = 3
- Max. $\Delta p = 0.03 \text{ bar}$

The capacity table is based on nominal conditions (recirculation rate = 4, pressure drop $\Delta p = 0.05 \text{ bar}$). Therefore the actual capacity must be corrected to the nominal condition by means of correction factors.

Correction factor for:
 Recirculation rate 3 ($f_{\text{rec.}}$) = 0.90
 Δp 0.03 bar ($f_{\Delta p}$) = 1.29

Nominal capacity, Q_N [kW]:
 $Q_N = Q_0 \times f_{\text{rec.}} \times f_{\Delta p}$
 $= 250 \times 0.90 \times 1.29 = 290 \text{ kW}$

From the capacity table a GPLX 100 with Q_N capacity $(264 + 328) \div 2 = \mathbf{296 \text{ kW}}$ is selected.

US units

Calculation example (R 22 capacities):

An application has the following running conditions:

- $T_e = -20^\circ\text{F}$
- $Q_0 = 50 \text{ TR}$
- Recirculating rate = 3
- Max. $\Delta p = 0.45 \text{ psi}$

The capacity table is based on nominal conditions (recirculation rate = 4, pressure drop $\Delta p = 0.75 \text{ psi}$). Therefore the actual capacity must be corrected to the nominal condition by means of correction factors.

Correction factor for:
 Recirculation rate 3 ($f_{\text{rec.}}$) = 0.90
 Δp 0.45 psi ($f_{\Delta p}$) = 1.29

Nominal capacity, Q_N [TR]:
 $Q_N = Q_0 \times f_{\text{rec.}} \times f_{\Delta p}$
 $= 50 \times 0.90 \times 1.29 = 58 \text{ TR}$

From the capacity table a GPLX 125 with Q_N capacity $(58.3 + 71.1) \div 2 = \mathbf{64.7 \text{ TR}}$ is selected.

Nominal capacities

Wet suction line

R 717

SI units

Capacity table at nominal conditions, Q_N [kW],
Recirculation rate = 4
 $\Delta p = 0.05$ bar

Type	k_v m ³ /h	Evaporating temperature T_e							
		-50°C	-40°C	-30°C	-20°C	-10°C	0°C	10°C	20°C
GPLX 80	131	120	155	193	234	279	326	376	428
GPLX 100	223	204	264	328	398	475	556	640	728
GPLX 125	370	338	438	544	661	788	922	1063	1208
GPLX 150	566	517	670	832	1011	1205	1410	1625	1847

Correction factor for Δp ($f_{\Delta p}$)

Δp (bar)	Correction factor
0.01	2.24
0.03	1.29
0.05	1.00
0.08	0.79
0.10	0.71
0.14	0.60

Correction factor for recirculating rate (f_{rec})

Recirculating rate	Correction factor
2.0	0.77
3.0	0.90
4.0	1.00
6.0	1.13
8.0	1.20
10.0	1.25

US units

Capacity table at nominal conditions, Q_N [Tons of Refrigeration],
Recirculating rate = 4.0
 $\Delta p = 0.75$ psi

R 717

Type	C_v USgal/min	Evaporating temperature T_e							
		-60°F *)	-40°F	-20°F	0°F	20°F	40°F	60°F	80°F
GPLX 80	152	33.4	44.8	56.8	70.7	85.2	100.7	116	133
GPLX 100	259	56.8	76.3	96.8	120.4	145	172	198	226
GPLX 125	429	94.1	126.4	160	199	241	284	329	374
GPLX 150	657	144	194	246	305	368	435	503	573

*) 2°F below min. operating temperature.

Correction factor for Δp ($f_{\Delta p}$)

Δp (psi)	Correction factor
0.15	2.24
0.45	1.29
0.75	1.00
1.25	0.77
1.75	0.65
2.25	0.58

Correction factor for recirculating rate (f_{rec})

Recirculating rate	Correction factor
2.0	0.77
3.0	0.90
4.0	1.00
6.0	1.13
8.0	1.20
10.0	1.25

Nominal capacities

Wet suction line

SI units

Capacity table at nominal conditions,
 Q_N [kW],
 Recirculation rate = 4
 $\Delta p = 0.05$ bar

R 22

Type	k_v m ³ /h	Evaporating temperature T_e							
		-50°C	-40°C	-30°C	-20°C	-10°C	0°C	10°C	20°C
GPLX 80	131	58.4	71.6	85.7	100.6	116.0	131.6	147.1	162.1
GPLX 100	223	99.4	121.8	145.9	171.3	197.5	224	250	276
GPLX 125	370	164.9	202.1	242	284	328	372	416	458
GPLX 150	566	252	309	370	435	501	569	636	700

Correction factor for Δp ($f_{\Delta p}$)

Δp (bar)	Correction factor
0.01	2.24
0.03	1.29
0.05	1.00
0.08	0.79
0.10	0.71
0.14	0.60

Correction factor for recirculating rate (f_{rec})

Recirculating rate	Correction factor
2.0	0.77
3.0	0.90
4.0	1.00
6.0	1.13
8.0	1.20
10.0	1.25

US units

Capacity table at nominal conditions,
 Q_N [Tons of Refrigeration],
 Recirculating rate = 4.0
 $\Delta p = 0.75$ psi

R 22

Type	C_v USgal/min	Evaporating temperature T_e							
		-60°F *)	-40°F	-20°F	0°F	20°F	40°F	60°F	80°F
GPLX 80	152	16.5	20.7	25.2	30.0	34.9	39.8	45.1	49.7
GPLX 100	259	28.1	35.2	42.9	51.1	59.4	67.8	76.9	84.7
GPLX 125	429	46.5	58.3	71.1	84.6	98.4	112.3	127.4	140.3
GPLX 150	657	71.3	89.4	108.9	129.5	151	172	195	215

*) 2°F below min. operating temperature.

Correction factor for Δp ($f_{\Delta p}$)

Δp (psi)	Correction factor
0.15	2.24
0.45	1.29
0.75	1.00
1.25	0.77
1.75	0.65
2.25	0.58

Correction factor for recirculating rate (f_{rec})

Recirculating rate	Correction factor
2.0	0.77
3.0	0.90
4.0	1.00
6.0	1.13
8.0	1.20
10.0	1.25

Nominal capacities

Wet suction line

R 404A

SI units

Capacity table at nominal conditions,
 Q_N [kW],
 Recirculation rate = 4
 $\Delta p = 0.05$ bar

Type	k_v m ³ /h	Evaporating temperature T_e							
		-50°C	-40°C	-30°C	-20°C	-10°C	0°C	10°C	20°C
GPLX 80	131	60.5	73.3	86.0	100.4	114.7	128.8	142.3	154.3
GPLX 100	223	103.0	124.8	146.4	170.9	195.3	219	242	263
GPLX 125	370	170.9	207.0	243	284	324	364	402	436
GPLX 150	566	261	317	372	434	496	556	615	667

Correction factor for Δp ($f_{\Delta p}$)

Δp (bar)	Correction factor
0.01	2.24
0.03	1.29
0.05	1.00
0.08	0.79
0.10	0.71
0.14	0.60

Correction factor for recirculating rate (f_{rec})

Recirculating rate	Correction factor
2.0	0.77
3.0	0.90
4.0	1.00
6.0	1.13
8.0	1.20
10.0	1.25

US units

Capacity table at nominal conditions,
 Q_N [Tons of Refrigeration],
 Recirculation rate = 4
 $\Delta p = 0.75$ psi

R 404A

Type	C_v USgal/min	Evaporating temperature T_e							
		-60°F *)	-40°F	-20°F	0°F	20°F	40°F	60°F	80°F
GPLX 80	152	17.1	21.2	25.3	29.8	34.4	38.8	43.2	46.6
GPLX 100	259	29.2	36.1	43.1	50.8	58.6	66.1	73.7	79.4
GPLX 125	429	48.3	59.7	71.5	84.2	97.0	109.5	122.1	131.5
GPLX 150	657	74.0	91.5	109.4	128.9	149	168	187	201

*) 2°F below min. operating temperature.

Correction factor for Δp ($f_{\Delta p}$)

Δp (psi)	Correction factor
0.15	2.24
0.45	1.29
0.75	1.00
1.25	0.77
1.75	0.65
2.25	0.58

Correction factor for recirculating rate (f_{rec})

Recirculating rate	Correction factor
2.0	0.77
3.0	0.90
4.0	1.00
6.0	1.13
8.0	1.20
10.0	1.25

Nominal capacities

Dry suction line

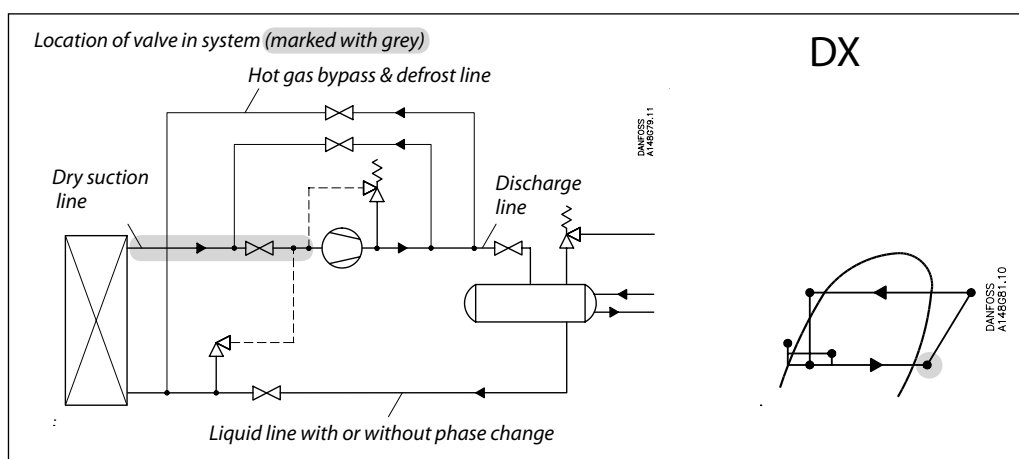
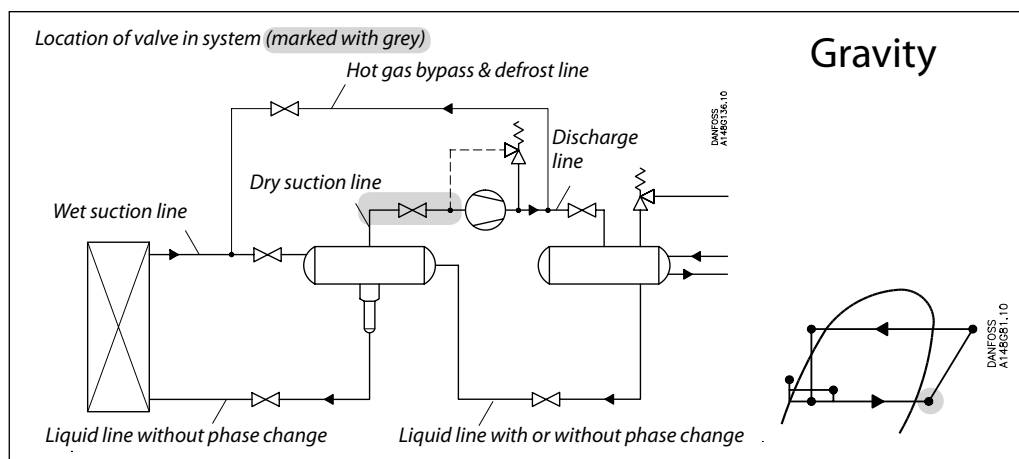
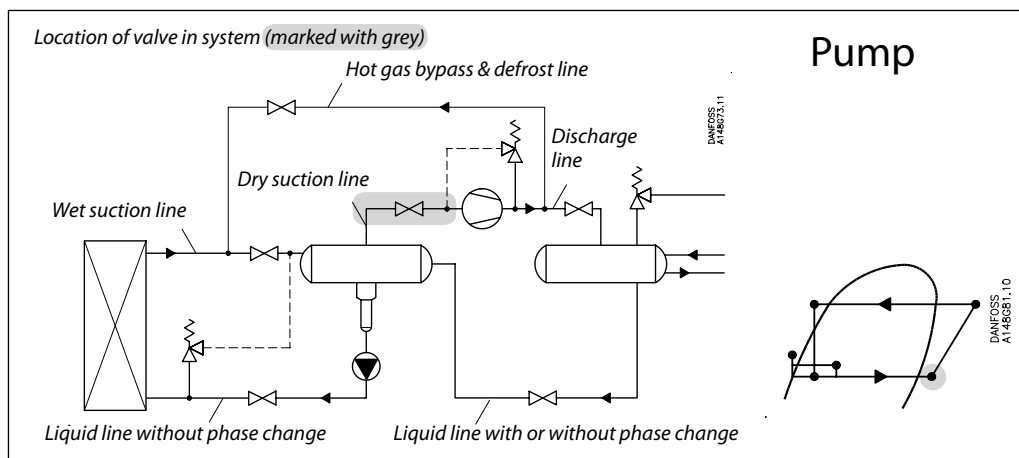

Nominal capacities

Dry suction line

SI units

Calculation example (R 717 capacities):

An application has the following running conditions:

- $T_e = -20^\circ\text{C}$
- $Q_0 = 650 \text{ kW}$
- Max. $\Delta p = 0.08 \text{ bar}$
- $T_{\text{liq.}} = 40^\circ\text{C}$
- $T_s = 12 \text{ K}$

The capacity table is based on nominal conditions ($T_{\text{liq.}} = 30^\circ\text{C}$, pressure drop $\Delta p = 0.05 \text{ bar}$, superheat $T_s = 8 \text{ K}$). Therefore the actual capacity must be corrected to the nominal condition by means of correction factors.

Correction factor for:

- $\Delta p 0.08 \text{ bar } f_{\Delta p} = 0.79$
- $T_{\text{liq.}} 40^\circ\text{C } f_{T_{\text{liq.}}} = 1.09$
- $T_s 12 \text{ K } f_{T_s} = 1.00$

Nominal capacity, Q_N [kW]:

$$Q_N = Q_0 \times f_{\Delta p} \times f_{T_{\text{liq.}}} \times f_{T_s} = 650 \times 0.79 \times 1.09 \times 1.00 = 560 \text{ kW}$$

From the capacity table a GPLX 100 with Q_N capacity **630 kW** is selected.

US units

Calculation example (R 22 capacities):

An application has the following running conditions:

- $T_e = -20^\circ\text{F}$
- $Q_0 = 105 \text{ TR}$
- Max. $\Delta p = 0.45 \text{ psi}$
- $T_{\text{liq.}} = 50^\circ\text{F}$
- $T_s = 20^\circ\text{F}$

The capacity table is based on nominal conditions ($T_{\text{liq.}} = 90^\circ\text{F}$, pressure drop $\Delta p = 0.75 \text{ psi}$, superheat $T_s = 20^\circ\text{F}$). Therefore the actual capacity must be corrected to the nominal condition by means of correction factors.

Correction factor for:

- $\Delta p 0.45 \text{ psi } (f_{\Delta p}) = 1.29$
- $T_{\text{liq.}} 50^\circ\text{F } (f_{T_{\text{liq.}}}) = 0.92$
- $T_s 20^\circ\text{F } (f_{T_s}) = 1.00$

$$Q_N = Q_0 \times f_{\Delta p} \times f_{T_{\text{liq.}}} \times f_{T_s} = 105 \times 1.29 \times 0.87 \times 1.00 = 118 \text{ TR}$$

From the capacity table a GPLX 150 (6 in.) with Q_N capacity **137 TR** is selected.

Nominal capacities

Dry suction line

R 717

SI units

Capacity table at nominal conditions,
 Q_N [kW],
 $T_{liq} = 30^\circ\text{C}$,
 $\Delta p = 0.05$ bar

Type	k_v m ³ /h	Evaporating temperature T_e							
		-50°C	-40°C	-30°C	-20°C	-10°C	0°C	10°C	20°C
GPLX 80	131	168.9	222.9	286	360	442	537	642	759
GPLX 100	223	288	379	486	612	753	914	1094	1292
GPLX 125	370	477	630	807	1016	1249	1516	1815	2144
GPLX 150	566	729.8	963	1234	1554	1910	2319	2776	3279

Correction factor for Δp ($f_{\Delta p}$)

Δp (bar)	Correction factor
0.01	2.24
0.03	1.29
0.05	1.00
0.08	0.79
0.10	0.71
0.14	0.60

Correction factor for superheat (T_s)

T_s	Correction factor
6 K	1.00
8 K	1.00
10 K	1.00
12 K	1.00

Correction factor for liquid temperature (T_{liq})

Liquid temperature	Correction factor
-20°C	0.82
-10°C	0.86
0°C	0.88
10°C	0.92
20°C	0.96
30°C	1.00
40°C	1.04
50°C	1.09

US units

Capacity table at nominal conditions,
 Q_N [Tons of Refrigeration],
 $T_{liq} = 90^\circ\text{F}$,
 $\Delta p = 0.75$ psi

R 717

Type	C_v USgal/min	Evaporating temperature T_e							
		-60°F *)	-40°F	-20°F	0°F	20°F	40°F	60°F	80°F
GPLX 80	152	46.8	64.4	84.1	107.4	135.8	167.7	201.6	240
GPLX 100	259	79.8	109.7	143.3	183.1	231.3	285.8	344	409
GPLX 125	429	132.2	181.7	237.4	303	383	473.4	569	678
GPLX 150	657	202.5	278	364	464	587	725	871	1038

* 2°F below min. operating temperature.

Correction factor for Δp ($f_{\Delta p}$)

Δp (psi)	Correction factor
0.15	2.24
0.45	1.29
0.75	1.00
1.25	0.77
1.75	0.65
2.25	0.58

Correction factor for superheat (T_s)

T_s	Correction factor
10°F	1.00
14°F	1.00
18°F	1.00
20°F	1.00

Correction factor for liquid temperature (T_{liq})

Liquid temperature	Correction factor
-10°F	0.82
10°F	0.85
30°F	0.88
50°F	0.92
70°F	0.96
90°F	1.00
110°F	1.04
130°F	1.09

Nominal capacities

Dry suction line

SI units

R 22

Capacity table at nominal conditions,
 Q_N [kW],
 $T_{liq} = 30^\circ\text{C}$,
 $\Delta p = 0.05$ bar

Type	k_v m ³ /h	Evaporating temperature T_e							
		-50°C	-40°C	-30°C	-20°C	-10°C	0°C	10°C	20°C
GPLX 80	131	66.5	86.2	109.3	136.5	166.0	200	238	280
GPLX 100	223	113.2	146.7	186.0	232	283	340	405	476
GPLX 125	370	187.8	243	309	385	469	565	672	790
GPLX 150	566	287	372	472	590	717	864	1027	1209

Correction factor for Δp ($f_{\Delta p}$)

Δp (bar)	Correction factor
0.01	2.24
0.03	1.29
0.05	1.00
0.08	0.79
0.10	0.71
0.14	0.60

Correction factor for superheat (T_s)

T_s	Correction factor
6 K	1.00
8 K	1.00
10 K	1.00
12 K	1.00

Correction factor for liquid temperature (T_{liq})

Liquid temperature	Correction factor
-20°C	0.71
-10°C	0.75
0°C	0.80
10°C	0.86
20°C	0.92
30°C	1.00
40°C	1.09
50°C	1.22

US units

R 22

Capacity table at nominal conditions,
 Q_N [Tons of Refrigeration],
 $T_{liq} = 90^\circ\text{F}$,
 $\Delta p = 0.75$ psi

Type	C_v USgal/min	Evaporating temperature T_e							
		-60°F *)	-40°F	-20°F	0°F	20°F	40°F	60°F	80°F
GPLX 80	152	18.4	24.5	31.8	40.2	50.0	61.0	74.7	88.7
GPLX 100	259	31.3	41.7	54.1	68.6	85.2	104.0	127.2	151
GPLX 125	429	51.9	69.1	89.6	113.6	141.1	172	211	250
GPLX 150	657	79.4	105.8	137	174	216	264	323	383

* 2°F below min. operating temperature.

Correction factor for Δp ($f_{\Delta p}$)

Δp (psi)	Correction factor
0.15	2.24
0.45	1.29
0.75	1.00
1.25	0.77
1.75	0.65
2.25	0.58

Correction factor for superheat (T_s)

T_s	Correction factor
10°F	1.00
14°F	1.00
18°F	1.00
20°F	1.00

Correction factor for liquid temperature (T_{liq})

Liquid temperature	Correction factor
-10°F	0.73
10°F	0.77
30°F	0.82
50°F	0.87
70°F	0.93
90°F	1.00
110°F	1.09
130°F	1.20

Nominal capacities

Dry suction line

R 134a

SI units

Capacity table at nominal conditions,
 Q_N [kW],
 $T_{liq} = 30^\circ\text{C}$,
 $\Delta p = 0.05$ bar

Type	k_v m ³ /h	Evaporating temperature T_e							
		-50°C	-40°C	-30°C	-20°C	-10°C	0°C	10°C	20°C
GPLX 80	131		56.6	74.8	97.2	123	153	187	227
GPLX 100	223		96.3	127.3	165	209	260	319	386
GPLX 125	370		160	211	275	346	431	529	641
GPLX 150	566		244	323	420	529	660	810	981

Correction factor for Δp ($f_{\Delta p}$)

Δp (bar)	Correction factor
0.01	2.24
0.03	1.29
0.05	1.00
0.08	0.79
0.10	0.71
0.14	0.60

Correction factor for superheat (T_s)

T_s	Correction factor
6 K	1.00
8 K	1.00
10 K	1.00
12 K	1.00

Correction factor for liquid temperature (T_{liq})

Liquid temperature	Correction factor
-20°C	0.66
-10°C	0.70
0°C	0.76
10°C	0.82
20°C	0.90
30°C	1.00
40°C	1.13
50°C	1.29

US units

Capacity table at nominal conditions,
 Q_N [Tons of Refrigeration],
 $T_{liq} = 90^\circ\text{F}$,
 $\Delta p = 0.75$ psi

R 134a

Type	C_v USgal/min	Evaporating temperature T_e							
		-60°F *)	-40°F	-20°F	0°F	20°F	40°F	60°F	80°F
GPLX 80	152		16.0	21.7	28.7	37.2	47.1	59.8	73.3
GPLX 100	259		27.2	37.0	49.0	63.3	80.3	101.9	124.9
GPLX 125	429		45.1	61.3	81.1	104.9	133.0	168.7	206.8
GPLX 150	657		69.1	93.9	124.2	161	204	258	317

* 2°F below min. operating temperature.

Correction factor for Δp ($f_{\Delta p}$)

Δp (psi)	Correction factor
0.15	2.24
0.45	1.29
0.75	1.00
1.25	0.77
1.75	0.65
2.25	0.58

Correction factor for superheat (T_s)

T_s	Correction factor
10°F	1.00
14°F	1.00
18°F	1.00
20°F	1.00

Correction factor for liquid temperature (T_{liq})

Liquid temperature	Correction factor
-10°F	0.64
10°F	0.68
30°F	0.74
50°F	0.81
70°F	0.89
90°F	1.00
110°F	1.15
130°F	1.35

Nominal capacities

Dry suction line

R 404A

SI units

Capacity table at nominal conditions,
 Q_N [kW],
 $T_{liq} = 30^\circ\text{C}$,
 $\Delta p = 0.05$ bar

Type	k_v m ³ /h	Evaporating temperature T_e							
		-50°C	-40°C	-30°C	-20°C	-10°C	0°C	10°C	20°C
GPLX 80	131	50.1	66.9	87.3	112.2	140.1	172.9	211	254
GPLX 100	223	85.2	113.8	148.7	190.9	238	294	359	432
GPLX 125	370	141.4	188.9	247	317	396	488	596	718
GPLX 150	566	216	289	377	485	605	747	911	1098

Correction factor for Δp ($f_{\Delta p}$)

Δp (bar)	Correction factor
0.01	2.24
0.03	1.29
0.05	1.00
0.08	0.79
0.10	0.71
0.14	0.60

Correction factor for superheat (T_s)

T_s	Correction factor
6 K	1.00
8 K	1.00
10 K	1.00
12 K	1.00

Correction factor for liquid temperature (T_{liq})

Liquid temperature	Correction factor
-20°C	0.55
-10°C	0.60
0°C	0.66
10°C	0.74
20°C	0.85
30°C	1.00
40°C	1.23
50°C	1.68

US units

Capacity table at nominal conditions,
 Q_N [Tons of Refrigeration],
 $T_{liq} = 90^\circ\text{F}$,
 $\Delta p = 0.75$ psi

R 404A

Type	C_v USgal/min	Evaporating temperature T_e							
		-60°F *)	-40°F	-20°F	0°F	20°F	40°F	60°F	80°F
GPLX 80	152	13.1	18.1	24.3	31.8	40.7	51.1	64.4	78.6
GPLX 100	259	22.3	30.8	41.4	54.1	69.3	87.1	109.8	133.9
GPLX 125	429	36.9	51.1	68.5	89.7	114.8	144.3	181.9	221.7
GPLX 150	657	56.6	80.6	105.0	137.3	175.8	221.0	278.5	339.6

* 2°F below min. operating temperature.

Correction factor for Δp ($f_{\Delta p}$)

Δp (psi)	Correction factor
0.15	2.24
0.45	1.29
0.75	1.00
1.25	0.77
1.75	0.65
2.25	0.58

Correction factor for superheat (T_s)

T_s	Correction factor
10°F	1.00
14°F	1.00
18°F	1.00
20°F	1.00

Correction factor for liquid temperature (T_{liq})

Liquid temperature	Correction factor
-10°F	0.52
10°F	0.57
30°F	0.63
50°F	0.72
70°F	0.83
90°F	1.00
110°F	1.29
130°F	1.92

**Hot Gas Defrosting
Pump circulation systems**
(flooded evaporators)

It is recommended to start the defrosting cycle by closing the EVRA valve in the liquid supply line and allowing some of the cold liquid contained in the evaporator to return to the liquid separator.

Close the GPLX valve in the wet suction line (flooded return line) and after a delay open the solenoid valve in the hot gas supply in order to build up the defrosting pressure in the evaporator.

Whenever a GPLX is installed in a liquid line, build-up of hydraulic pressure must be avoided.

After defrosting, the GPLX should be opened to allow the evaporator pressure to equalise with the suction side before opening the EVRA in the liquid supply line.

GPLX valves are designed to allow the equalisation of pressures between evaporator pressure and system suction pressure, which eliminates the need to install an external by-pass around the GPLX valve.

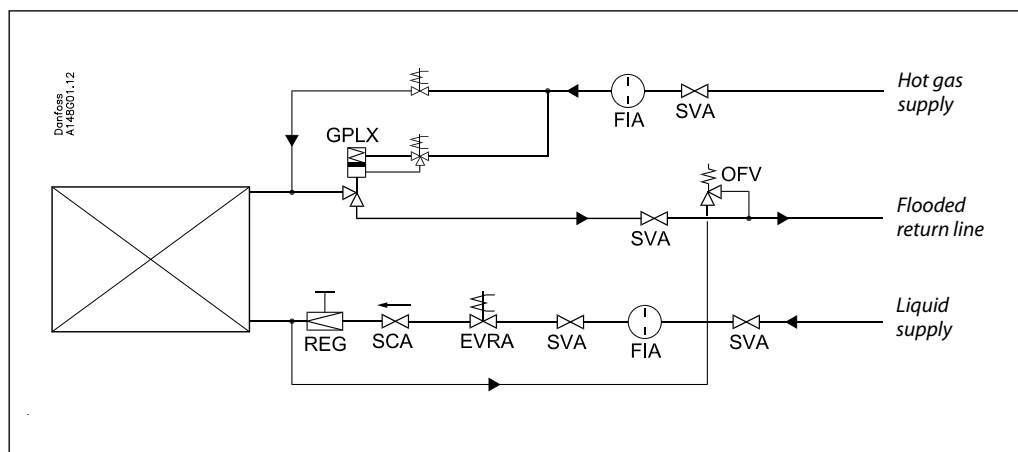

Material specification

No.	Part	Material	EN	ASTM	JIS
1	Valve Housing	Steel	G20Mn5 QT EN 10213-3	LCC A 352	SCPL1 G 5152
2	Bonnet	Steel	P285QH EN 10222-4	LF2 A350	SFL 2 G 3205
3	Valve spindle	Steel			
4	Piston rod	Steel			
5	Cylinder	Steel			
6	Piston	Steel			
7	Spindle guide	Steel			
8	Valve cone back	Steel			
9	Valve cone bush	Steel			
10	Valve front cone	Steel			
11	Spindle top thread bush	Steel			
12	Valve top cap	Steel			
13	Manual opening spindle	Steel			
14	Bushing for spring	Steel			
15	Inner spring for opening	Steel			
16	Outer spring for closing	Steel			

Material specification
(cont.)

No.	Part	Material	EN	ASTM	JIS
17	Top gasket	Fiber, Non-asbestos			
18	Teflon ring step 2	PTFE			
19	Teflon ring step 1	PTFE			
20	Cone nut	Steel			
21	Cone nut disc	Steel			
22	Cone assembly screw	Steel			
23	Cylinder screw	Steel			
24	Hexagon set screw	Stainless steel	A2-70 EN 1515-1	Type 308 A276	A2-70 B 1054
25	O-ring	Cloroprene (Neoprene)			
26	O-ring	Cloroprene (Neoprene)			
27	Piston sealing ring	PTFE			
28	O-ring	Cloroprene (Neoprene)			
29	Spindle sealing ring	PTFE			
30	Sealing ring	PTFE			
31	Solenoid valve, EVRB				
32	Solenoid fixing screw	Steel			
33	Bushing	Steel			
34	O-ring	Cloroprene (Neoprene)			
35	O-ring	Cloroprene (Neoprene)			
36	O-ring	Cloroprene (Neoprene)			
37	Top cap fixing screw	Steel			
38	Spring ring	Steel			
39	Gasket for cylinder top	Fiber, Non-asbestos			
40	O-ring	Cloroprene (Neoprene)			
41	Marking plate	Steel			

Connections

DIN

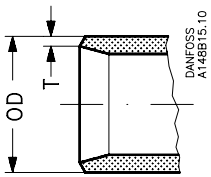

Size		OD	T	OD	T			K _v -angle	C _v -angle	K _v -angle	C _v -angle
mm	in.	mm	mm	in.	in.			m ³ /h	USgal/min	m ³ /h	USgal/min
Welding DIN (2448)											
						First opening step			Fully open		
80	3	88.9	3.2	3.50	0.13			7.7	9	131	152
100	4	114.3	3.6	4.50	0.14			12.0	14	223	259
125	5	139.7	4.0	5.50	0.16			24.0	28	370	429
150	6	168.3	4.5	6.63	0.18			36.0	42	566	657

ANSI

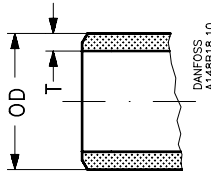

Size		OD	T	OD	T			K _v -angle	C _v -angle	K _v -angle	C _v -angle
mm	in.	mm	mm	in.	in.			m ³ /h	USgal/min	m ³ /h	USgal/min
Welding ANSI (B 36.10)											
						First opening step			Fully open		
80	3	88.9	5.5	3.50	0.22			7.7	9	131	152
100	4	114.3	6.0	4.50	0.24			12.0	14	223	259
125	5	139.7	6.6	5.50	0.26			24.0	28	370	429
150	6	168.3	7.1	6.63	0.28			36.0	42	566	657

Dimensions and weights

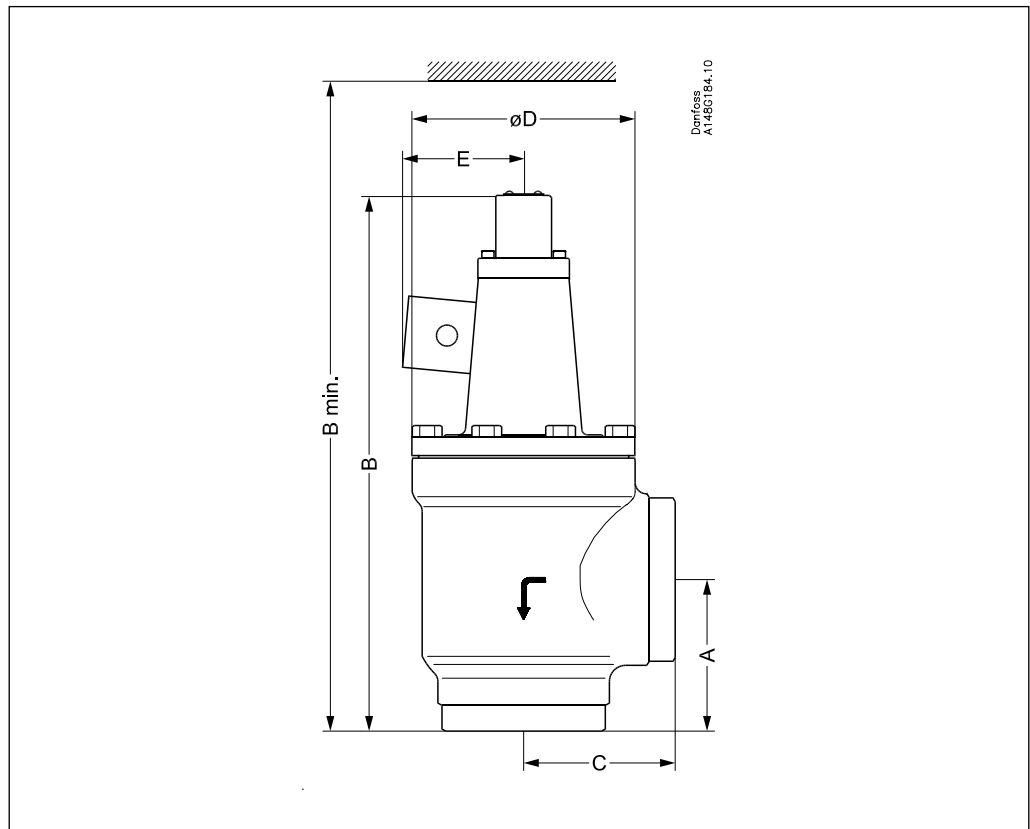

Valve size		A	B	B _{min}	C	ØD	E	Weight
GPLX 80-150								
GPLX 80 (3 in.)	mm	100	390	570	100	155	135	20.0 kg
	in.	3.9	15.4	22.4	3.9	6.1	5.3	
GPLX 100 (4 in.)	mm	125	500	725	125	190	150	33.0 kg
	in.	4.9	19.7	28.5	4.9	7.5	5.9	
GPLX 125 (5 in.)	mm	150	565	790	150	190	150	45.0 kg
	in.	5.9	22.2	31.1	5.9	7.5	5.9	
GPLX 150 (6 in.)	mm	180	620	845	180	190	150	65.0 kg
	in.	7.1	24.4	33.3	7.1	7.5	5.9	

Specified weights are approximate values only.

Ordering

GPLX valves are supplied complete with EVRB pilot valve less solenoid coils.
Please select required coils from the table below. The coils will be supplied loose for site assembly.

DIN butt-weld:

mm	Size		Type	Code number
	in.			
80	3		GPLX 80 D	148G3151
100	4		GPLX 100 D	148G3152
125	5		GPLX 125 D	148G3153
150	6		GPLX 150 D	148G3154

ANSI butt-weld:

mm	Size		Type	Code number
	in.			
80	3		GPLX 80 A	148G3155
100	4		GPLX 100 A	148G3156
125	5		GPLX 125 A	148G3157
150	6		GPLX 150 A	148G3158

D = DIN butt-weld
A = ANSI butt-weld

Important!

Where products need to be certified according to specific certification societies or where higher pressures are required, the relevant information should be included at the time of order.

Please select a set of coils (two pieces) from the list below:

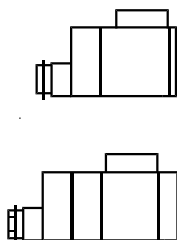

Sets of coils	Code number
24V 50Hz 10W	018F6707
24V 50Hz 12W	018F6807
110V 50/60Hz 10W	018F6730
110V 60Hz 12W	018F6813
220/230V 50Hz 10W	018F6701
220/230V 50Hz 12W	018F6801
220V 60Hz 10W	018F6714
220V 60Hz 12W	018F6814
24V d.c. - 20W	018F6857
110V d.c. - 20W	018F6860
220V d.c. - 20W	018F6851



Note:
Always use coils with the same voltage as the rated power supply.

For further information please contact your local Danfoss Sales Company.

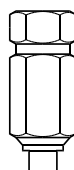

Optional:
Filter for pilot connection with threaded connection - 1/4" BSP male:

Type	Code number
FIL 6 R 1/4"	2464+608

