

Fig. 1, Push rod assembly for PM 1 and 3, sizes 5 to 25

Fig. 2, PM 1, sizes 5 to 25

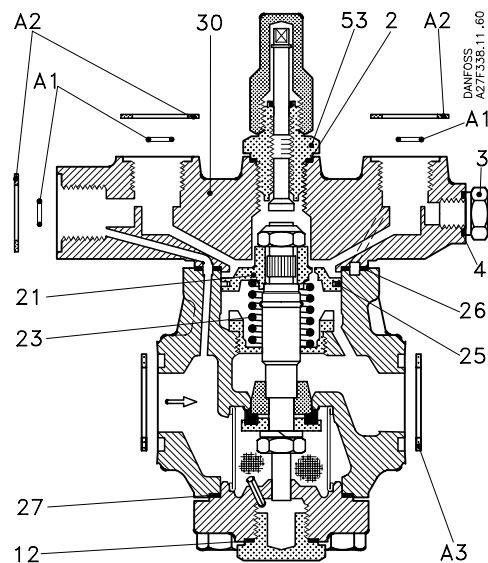

Fig. 3, PM 3, sizes 5 to 25

Description	Qty	Size 5	Size 10	Size 15	Size 20	Size 25
		Code no.	Code no.	Code no.	Code no.	Code no.
Push rod assembly, fig 1		027F0160	027F0161	027F0162	027F0260	027F0261
Pos. 1 Push rod	1					
2 Cone	1					
3 Valve plate	1					
4 Clamping plate	1					
5 Nut	1					
6 Spring washer	1					
7 Nut	1					
8 Locking ring	1					
Valve plate, fig. 1		027F0683	027F0683	027F0683	027F0683	027F0683
Pos. 3 Valve plate	1					
Piston ring, figs. 2 and 3		027F0650	027F0650	027F0650	027F0650	027F0650
Pos. 25 Piston ring	1					
Piston assembly, figs. 2 and 3		027F0395	027F0395	027F0395	027F0395	027F0395
Pos. 21 Piston	1					
25 Piston ring	1					
Servo spring, figs. 2 and 3		027F0901	027F0901	027F0901	027F0901	027F0901
Pos. 23 Spring	1					
Strainer, figs. 2 and 3		027F0657	027F0657	027F0657	027F0657	027F0657
Pos. 24 Strainer	1					
Top cover, PM 1, fig. 2		027F0640	027F0640	027F0640	027F0640	027F0640
Pos. 2 Alu gasket	1					
3 Plug	1					
4 Alu gasket	1					
26 Gasket	1					
30 Top cover	1					
53 Manual operation	1					

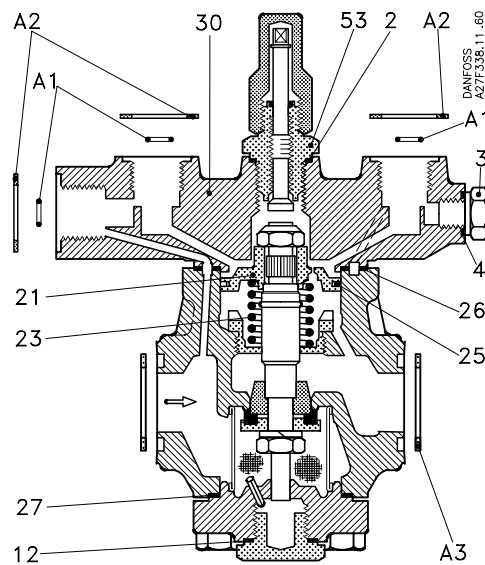
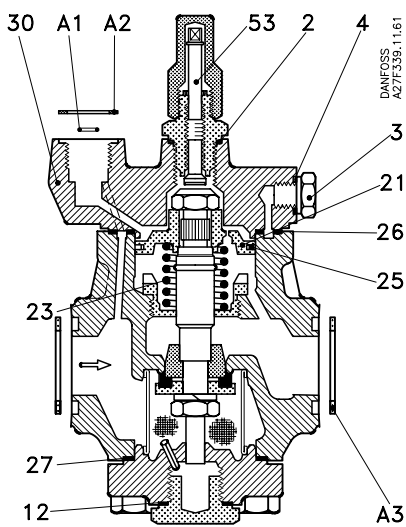
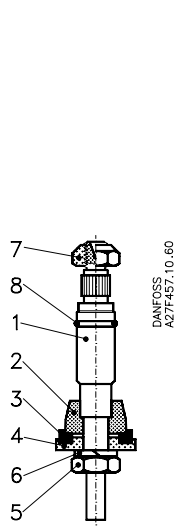

Fig. 1, Push rod assembly for PM 1 and 3, sizes 5 to 25

Fig. 2, PM 1, sizes 5 to 25

Fig. 3, PM 3, sizes 5 to 25

Description	Qty	Size 5	Size 10	Size 15	Size 20	Size 25
		Code no.	Code no.	Code no.	Code no.	Code no.
Top cover, PM 3, fig. 3		027F0645	027F0645	027F0645	027F0645	027F0645
Pos. 2 Alu gasket	1					
3 Plug	1					
4 Alu gasket	1					
26 Gasket	1					
30 Top cover	1					
53 Manual operation	1					
Manual operation, figs. 2 and 3		027F2130	027F2130	027F2130	027F2130	027F2130
Pos. 2 Alu gasket	1					
53 Manual operation	1					
Seal kit, figs. 2 and 3		027F2170	027F2170	027F2170	027F2170	027F2170
Pos. 26 Gasket	1					
27 Gasket	1					
Seal kit, figs. 2 and 3		027F0086	027F0086	027F0086	027F0086	027F0086
Pos. 2 Alu gasket	1					
4 Alu gasket	1					
12 Gasket	1					
26 Gasket	1					
27 Gasket	1					
A1 O-ring	3					
A2 Gasket	3					
A3 Gasket	2					
Flange gaskets, figs. 2 and 3		027F2175	027F2175	027F2175	027F2175	027F2175
Pos. A3 Gasket	2					

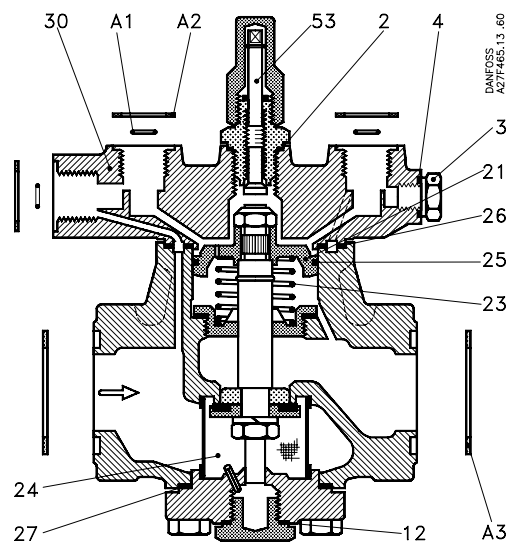
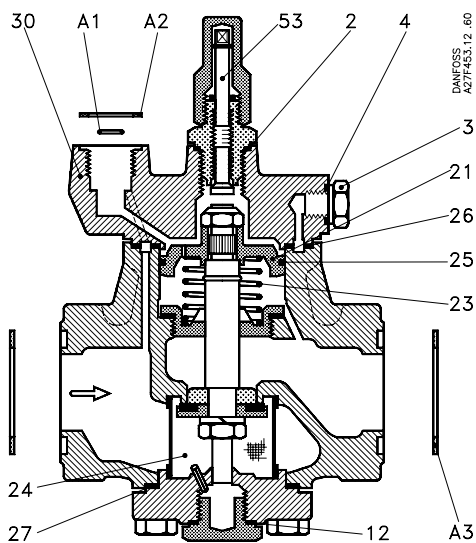
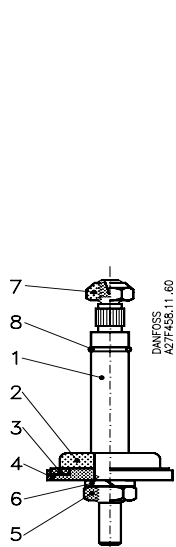

Fig. 1, Push rod assembly for PM 1 and 3 sizes 32 to 65

Fig. 2, PM 1, sizes 32 to 65

Fig. 3, PM 3, sizes 32 to 65

Description	Qty	Size 32	Size 40	Size 50	Size 65
		Code no.	Code no.	Code no.	Code no.
Push rod assembly, fig. 1		027F0262	027F0263	027F0264	027F0265
Pos. 1 Push rod	1				
2 Cone	1				
3 Valve plate	1				
4 Clamping plate	1				
5 Nut	1				
6 Spring washer	1				
7 Nut	1				
8 Locking ring	1				
Valve plate, fig. 1		027F0684	027F0685	027F0686	027F0687
Pos. 3 Valve plate	1				
Piston ring, figs. 2 and 3		027F0651	027F0652	027F0653	027F0654
Pos. 25 Piston ring	1				
Piston assembly, figs. 2 and 3		027F0396	027F0397	027F0398	027F0399
Pos. 21 Piston	1				
25 Piston ring	1				
Servo spring, figs. 2 and 3		027F0902	027F0903	027F0904	027F0905
Pos. 23 Spring	1				
Strainer, figs. 2 and 3		027F0658	027F0659	027F0660	027F0661
Pos. 24 Strainer	1				
Top cover, PM 1, fig. 2		027F0641	027F0642	027F0643	027F0644
Pos. 2 Alu gasket	1				
3 Plug	1				
4 Alu gasket	1				
26 Gasket	1				
30 Top cover	1				
53 Manual operation	1				

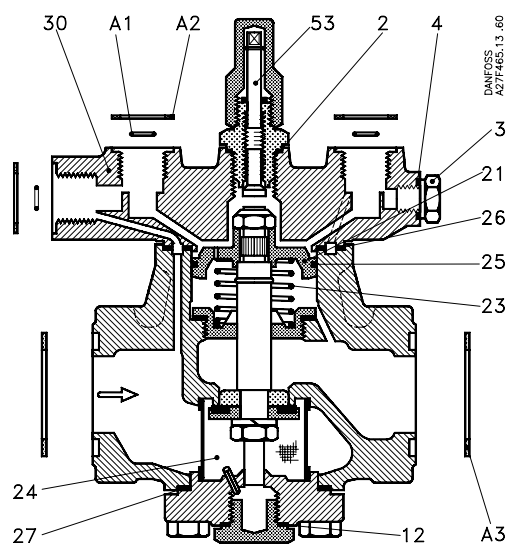
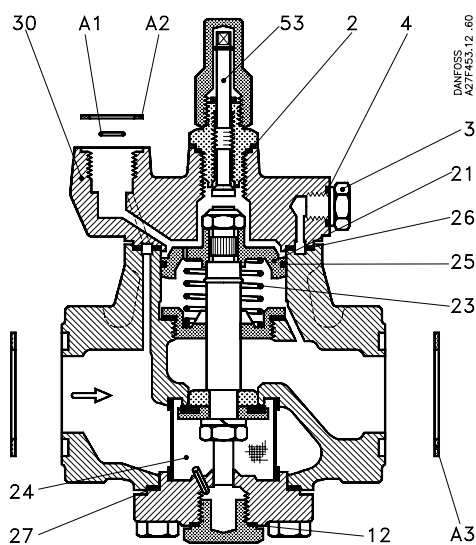
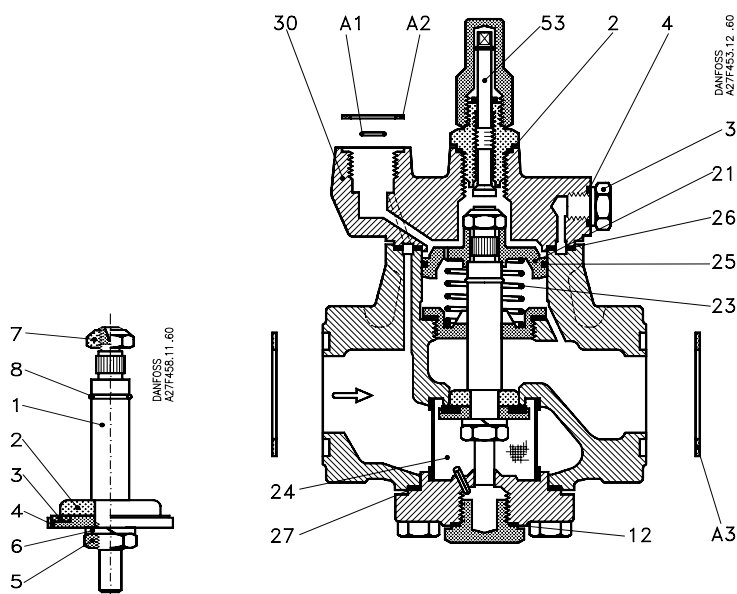

Fig. 1, Push rod assembly for PM 1 and 3, sizes 32 to 65

Fig. 2, PM 1, sizes 32 to 65

Fig. 3, PM 3, sizes 32 to 65

		Size 32	Size 40	Size 50	Size 65
Description	Qty	Code no.	Code no.	Code no.	Code no.
Top cover, PM 3, fig. 3					
Pos. 2 Alu gasket	1	027F0646	027F0647	027F0648	027F0656
3 Plug	1				
4 Alu gasket	1				
26 Gasket	1				
30 Top cover	1				
53 Manual operation	1				
Manual operation, figs. 2 and 3					
Pos. 2 Alu gasket	1	027F2130	027F2130	027F2130	027F2130
53 Manual operation	1				
Seal kit, figs. 2 and 3					
Pos. 26 Gasket	1	027F2171	027F2172	027F2173	027F2174
27 Gasket	1				
Seal kit, figs. 2 and 3					
Pos. 2 Alu gasket	1	027F0087	027F0088	027F0089	027F0090
4 Alu gasket	1				
12 Gasket	1				
26 Gasket	1				
27 Gasket	1				
A1 O-ring	3				
A2 Gasket	3				
A3 Gasket	2				
Flange gaskets, figs. 2 and 3					
Pos. A3 Gasket	2	027F2176	027F2177	027F2178	027F2179

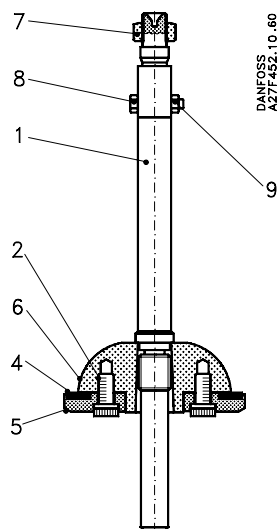

Fig. 1, Push rod assembly for PM 3, sizes 80 to 125

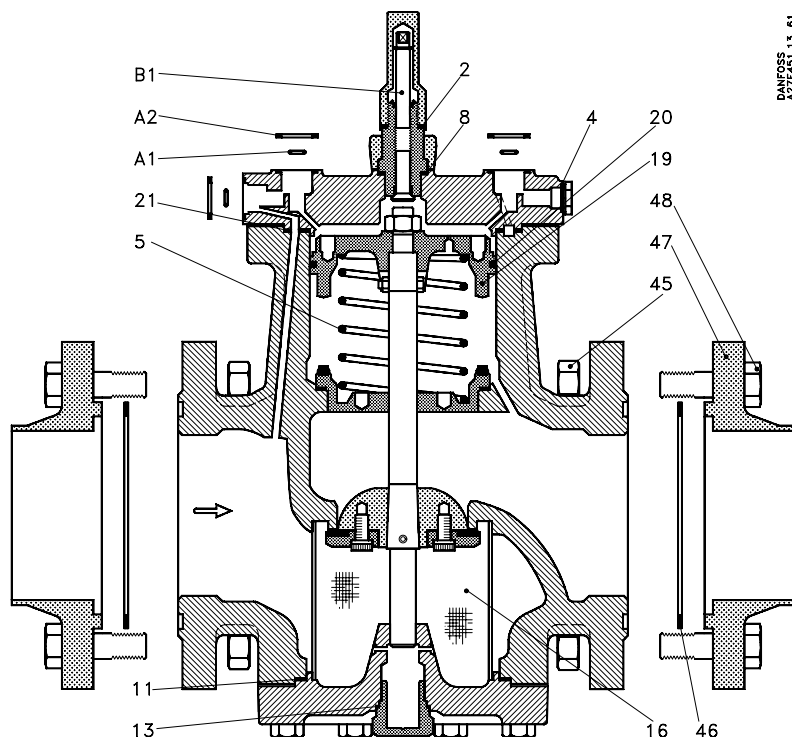

Fig. 2, PM 3, sizes 80 to 125

Description	Qty	Size 80	Size 100	Size 125
		Code no.	Code no.	Code no.
Push rod assembly, fig. 1		027F1204	027F1205	027F1206
Pos. 1 Push rod	1			
2 Screw	6			
4 Valve plate	1			
5 Clamping plate	1			
6 Cone	1			
7 Nut	1			
8 Screw	1			
9 Nut	1			
Valve plate, fig. 1		027F0692	027F0693	027F0694
Pos. 4 Valve plate	1			
Manual operation, fig. 2		027F2134	027F2134	027F2134
Pos. 8 Gasket	1			
B1 Manual operation	1			
Piston ring, fig. 2		027F1246	027F1247	027F1248
Pos. 20 Piston ring	1			
Piston assembly, fig. 2		027F2150	027F2151	027F2152
Pos. 19 Piston	1			
20 Piston ring	1			
Servo spring, fig. 2		027F2140	027F2141	027F2142
Pos. 5 Spring	1			
Strainer, fig. 2		027F2135	027F2136	027F2137
Pos. 16 Strainer	1			
Seal kit, fig. 2		027F2180	027F2181	027F2182
Pos. 11 Gasket	1			
21 Gasket	1			

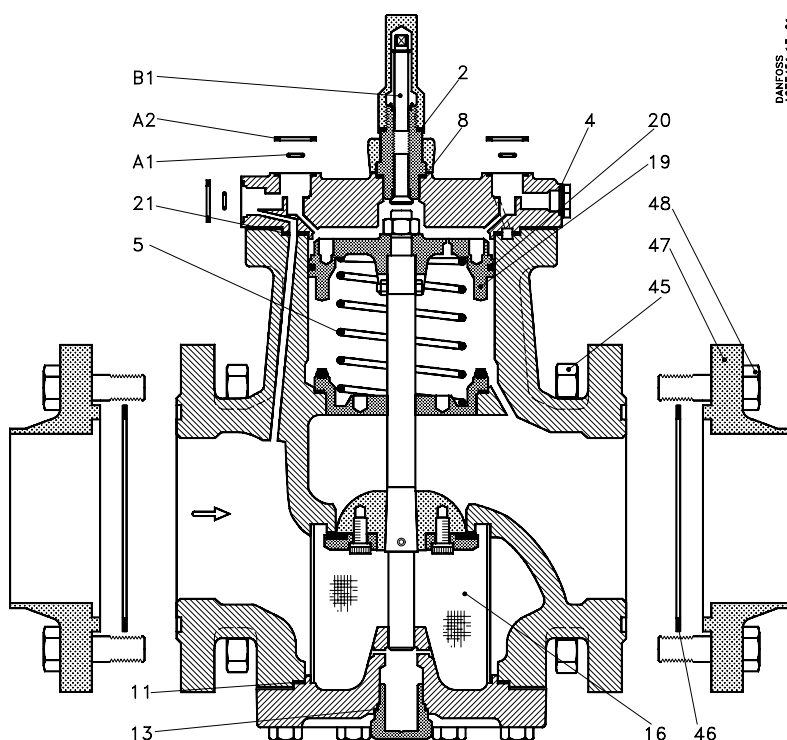
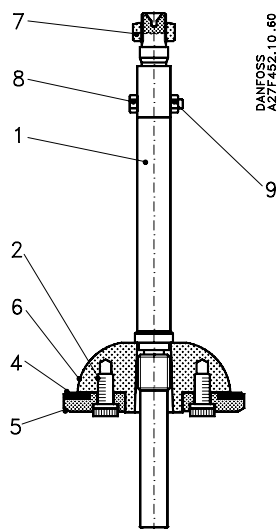











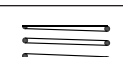



Fig. 1, Push rod assembly for PM 3, sizes 80 to 125

Fig. 2, PM 3, sizes 80 to 125

Description	Qty	Size 80	Size 100	Size 125
		Code no.	Code no.	Code no.
Seal kit, fig. 2		027F1230	027F1231	027F1232
Pos. 2 Alu gasket	1			
4 Alu gasket	1			
8 Gasket	1			
11 Gasket	1			
13 Alu gasket	1			
21 Gasket	1			
46 Gasket	2			
A1 O-ring	3			
A2 Gasket	2			
Flange set, fig. 2		027F2123	027F2124	027F2125
Pos. 47 Flange	2			
Flange gaskets, fig. 2		027F2120	027F2121	027F2122
Pos. 46 Gasket	2			
Flange bolts and nuts, fig. 2		027F2126	027F2127	027F2128
Pos. 45 Nut	16			
48 Bolt	16			

Spare parts and accessories
Main valves, type PM 1 and PM 3

Accessories for PMC	Description	Qty	Code no.
	External pilot connector Weld, PM 5 to 65, ID 12.7 mm/OD 18 mm Weld, PM 80 to 125, ID 12.7 mm/OD 18 mm 1/4 NPT, PM 5 to 65 1/4 NPT, PM 80 to 125 Nipple assembly Damping orifice, dia. 1.0 mm O-ring Gasket	 	
	Seal kit for external pilot connector Alu gasket Gasket O-ring	 	
	Blanking plug Plug Stop plug O-ring Gasket	 	
	Pressure gauge connector, solder/weld Nipple assembly Alu gasket	 	
	Seal kit for solder/weld pressure gauge connector Alu gasket Alu gasket	 	
	Pressure gauge connector cutting ring connector 6 mm 10 mm	 	
	Pressure gauge connector, 1/4 NPT		
	Pressure gauge connector, flare (Must not be used in ammonia systems!) Nipple Schraeder valve Cap Alu gasket	 	
	Function indicator for PM/PMC 1 and 3, sizes 5 to 65 Function indicator assembly Gasket	 	
	CVH pilot valve body weld ID 12.7 mm/OD 18 mm		
	CVH pilot valve body G 1/4 (ISO 228-1)		
	CVH pilot valve body G 1/4 (USAS B2.1-1960)		
	„Strong“ spring for PM 1 and 3, sizes 5 to 25, approx. 45% more closing force		