

Motor valves
type ICM

Actuators
type ICAD

Contents

	Page
Introduction	3
The ICM Concept	4
Features (valve)	5
Design (valve)	5
Technical data (valve)	5
Function (valve)	6
Features (actuator)	7
Technical data (actuator)	7
Electrical data	7
Cable connection	8
Approvals	8
Function (actuator)	8
ICAD-UPS for ICM 20-125	9
Facts and features	9
ICAD-UPS applications	10
Material specification	11
ICM Application	12
Recommended filters	12
Nominal capacities:	
Liquid line with/without phase change	13
Liquid line without phase change	19
Wet suction line	25
Dry suction line	31
Discharge line	37
Expansion capacities	43
R 717	44
R 744	45
R 134a	46
R 404A	47
R 22	48
Ordering:	
ICM 20 / ICAD 600	49
ICM 25 / ICAD 600	50
ICM 32 / ICAD 600	51
ICM 40 / ICAD 900	52
ICM 50 / ICAD 900	53
ICM 65 / ICAD 900	54
Dimensions:	
ICM 20 / ICAD 600	55
ICM 25 / ICAD 600	56
ICM 32 / ICAD 600	57
ICM 40 / ICAD 900	58
ICM 50 / ICAD 900	59
ICM 65 / ICAD 900	60
Connections	61
Actuator setup:	
General operation	62
Alarms	63
Parameter list	63
Reset to factory setting	64

Introduction



ICM motor valves belong to the ICV (Industrial Control Valve) family and are one of two product groups.

ICV types

- ICS - Industrial Control Servo
- ICM - Industrial Control Motor

The motor valve comprises three main components: valve body, combined top cover / function module and actuator.

ICM are direct operated motorised valves driven by actuator type ICAD (Industrial Control Actuator with Display).

ICM valves are designed to regulate an expansion process in liquid lines with or without phase change or control pressure or temperature in dry and wet suction lines and hot gas lines. ICM valves are designed so that the opening and closing forces are balanced, therefore, only two sizes of ICAD actuators are needed for the complete range of ICM from DN 20 to DN 65. The ICM motorised valve and ICAD actuator assembly offers a very compact unit with small dimensions.

The ICM motorised valve and ICAD actuator combinations are as follows:

Actuator	ICAD 600	ICAD 900
Valve size	ICM 20	ICM 40
	ICM 25	ICM 50
	ICM 32	ICM 65

ICAD 600 / ICAD 900

ICAD actuators can be controlled using the following signals:

- 0-20 mA
- 4-20 mA (default)
- 0-10 V
- 2-10 V

ICAD actuators can also operate an ICM valve as an On/Off function supported by a digital input.

The ICM valve can be operated manually via the ICAD actuator or the Multi-function tool for ICM (see the ordering section).

Fail Safe supply options

In the event of a power failure, multiple fail safe options are possible, provided that a ICAD-UPS or similar is used.

During power failure, ICM can be selected to:

- Close ICM
 - Open ICM
 - Stay in the same position, as when power failure occurs
 - Go to a specific ICM valve opening degree
- See the section ICAD UPS for further information.

Please note: a fail safe supply (battery or UPS) is required.

The ICM Concept

The ICM concept is developed around a modular principle. This gives the possibility of combining function modules and top covers with special valve body size that is available in a variety of connection possibilities.

- There are six valve bodies available.

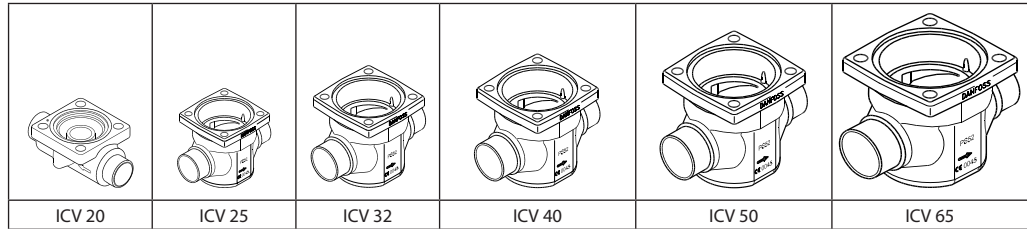

- Each valve body is available with a range of undersized through oversized connection sizes and types.

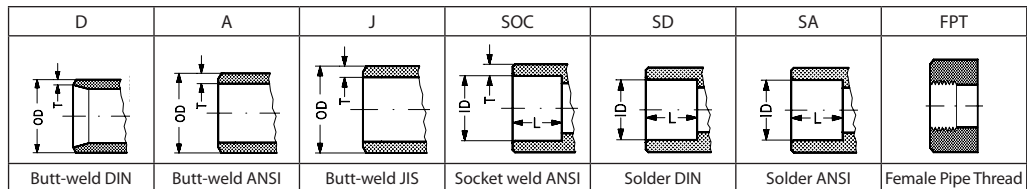

- Each body may be fitted with multiple function / top cover to give different capacities.

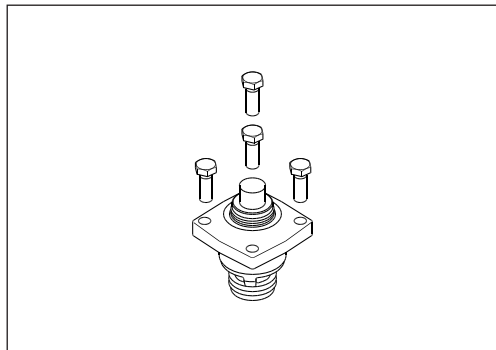

Type	Valve body size	K _v (m ³ /h)	C _v (USgal/min)
ICM20-A	20	0.6	0.7
ICM20-B		2.4	2.8
ICM20-C		4.6	5.3
ICM25-A	25	6	7.0
ICM25-B		12	13.9
ICM32-A	32	9	10.4
ICM32-B		17	20
ICM40-A	40	15	17
ICM40-B		26	30
ICM50-A	50	23	27
ICM50-B		40	46
ICM65-B	65	70	81

A magnetic coupled actuator is easily installed. Only two actuators are needed to cover the entire ICM program

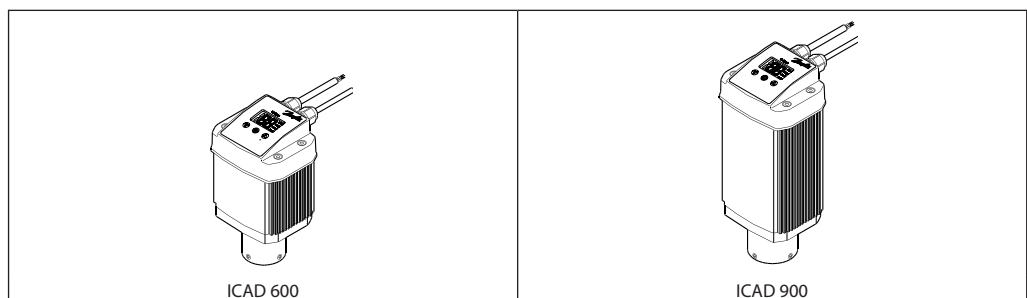

Features (valve)

- Designed for Industrial Refrigeration applications for a maximum working pressure of 52 bar / 754 psig.
- Applicable to all common refrigerants including R717 and R744 (CO₂) and non corrosive gases/liquids.
- Direct coupled connections.
- Connection types include butt weld, socket weld, solder and threaded connections.
- Low temperature steel body.
- Low weight and compact design.
- V-port regulating cone ensures optimum regulating accuracy particularly at part load.
- Cavitation resistant valve seat.
- Modular Concept
 - Each valve body is available with several different connection types and sizes.
 - Valve overhaul is performed by replacing the function module.
 - Possible to convert ICM motor valve to ICS servo valve.
- Manual opening possible via ICAD or Multi-function tool.
- PTFE seat provides excellent valve tightness.
- Magnet coupling - real hermetic sealing.

Design (valve)
Connections

There is a very wide range of connection types available with ICM valves:

- D: Butt weld, DIN (2448)
- A: Butt weld, ANSI (B 36.10)
- J: Butt weld, JIS (B S 602)
- SOC: Socket weld, ANSI (B 16.11)
- SD: Solder connection, DIN (2856)
- SA: Solder connection, ANSI (B 16.22)
- FPT: Female pipe thread (ANSI/ASME B 1.20.1)

Valve body and top cover material

Low temperature steel

Approvals

The ICV valve concept is designed to fulfil global refrigeration requirements.

For specific approval information, please contact Danfoss.

The ICM valves are approved in accordance with the European standard specified in the Pressure Equipment Directive and are CE marked.

For further details / restrictions - see Installation Instruction.



ICM valves		
Nominal bore	DN ≤ 25 (1 in.)	DN 32-65 mm (1 1/4 - 2 1/2 in.)
Classified for	Fluid group I	
Category	Article 3, paragraph 3	II

Technical data (valve)

- *Refrigerants*
Applicable to all common refrigerants including R717 and R744 (CO₂) and non-corrosive gases/liquids.
Use with flammable hydrocarbons cannot be recommended. For further information please contact your local Danfoss sales company.
- *Temperature range:*
Media: -60/+120°C (-76/+248°F).
- *Pressure*
The valve is designed for:
Max. working pressure: 52 bar g (754 psig)
- *Surface protection*
ICM 20-65:
The external surface is zinc-chromated to provide good corrosion protection.
- *Max. opening pressure differential (MOPD)*
 - ICM 20-32: 52 bar (750 psi)
 - ICM 40: 40 bar (580 psi)
 - ICM 50: 30 bar (435 psi)
 - ICM 65: 20 bar (290 psi)

Function (valve)

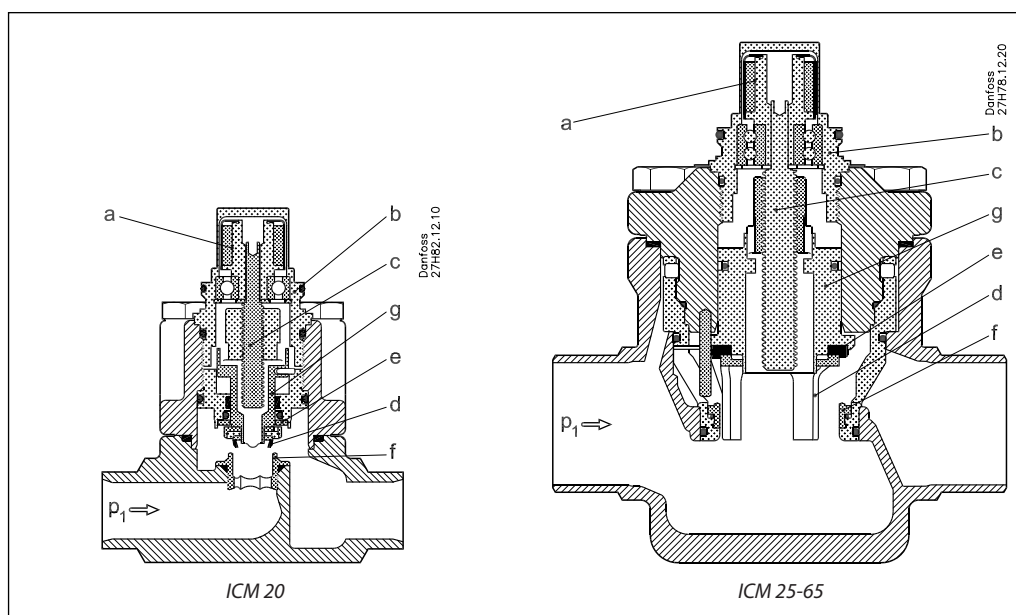

ICM, Industrial Control Motor valves are designed for use with the ICAD, Industrial Control Actuator with Display.

The driving force from the actuator is transferred via a magnetic coupling (a) through the stainless steel top housing (b) and thus eliminates the need for a packing gland. The rotational movement of the magnetic coupling (a) is transferred to a spindle (c) which in turn provides the vertical movement of the cone (d) and PTFE valve plate (e), to open and close the valve. The closing force of the actuator, combined with the PTFE valve plate (e) and cavitation resistant valve seat (f), provides an effective seal to prevent leakage across the valve port, when the valve is in the closed position. To prevent damage to the PTFE valve plate (e) and seat (f) from system debris, it is recommended that a filter is installed upstream of the valve. Please refer to page 10 for filter sizing and application recommendations.

Valve inlet pressure (P_1) acting on the underside of the PTFE valve plate (e) also passes through the hollow cone assembly (d) on to the top of the piston (g) and balances the pressure acting on the piston (g). Any trapped liquid across the throttle cone (d) is allowed to equalise down to the valve outlet without affecting the valve performance.

There are two sizes of ICAD actuator that cover the range of valves from ICM 20 to ICM 65.

The actuators have a fully weather protected enclosure with none of the moving parts exposed to the environment. Spindle and electronic heating elements are not required.

The fast acting actuators and balanced valve design results in the valve being able to move from the fully closed to the fully open position in between 3 to 13 seconds depending on valve size.

The cone (d) includes V-shaped grooves, which provides stable control regulation, particularly at low load conditions. Each valve size has at least two different function modules capacities to select from.

The function modules are designed for different capacities and are designated A and B, (and C in the case of the ICM 20). In general, "A" modules are for liquid applications. The "B" (C) modules have larger capacities than the "A" modules and are mainly for suction applications.

ICAD

Actuator types ICAD 600 and 900 are dedicated for use with ICM motorised valves. There are only two sizes of ICAD actuators that cover the range of valves from ICM 20 to ICM 65.

The ICAD is controlled via a modulating analogue signal (e.g. 4-20 mA/2-10 V) or a digital ON/OFF

signal. ICAD incorporates an advanced MMI (Man Machine Interface), including continuous display of Opening Degree, which gives the user a very advanced and flexible setup procedure that can meet many different applications.

Features (actuator)

- Specifically designed for industrial refrigeration installations
- Advanced and high speed Digital Stepper Motor Technology
- Seven segment LCD display and three programming keys included
- Valve opening degree can be observed continuously.
- Can easily be configured to different applications on-site. (change speed, ON/OFF, modulating valve)
- Open – Close time: 3-13 seconds depending on valve size
- Modulating or ON/OFF operation
- Multiple speed selection during operation
- Logging of old alarms
- Password protection
- Control input signal :
4-20 mA, 0-20 mA, 0-10 V, 2-10 V
- Position feed back : 0-20 mA, 4-20 mA (ICM)
- 3 Digital ON/OFF feedback
- Resolution: 20 micron/step (0.02 mm stroke pr. step)
- Total steps: 250 – 1000 depending on size
- Auto Calibration, Neutral zone
- In the event of a power failure, multiple fail safe options are possible. During power failure, ICM can be selected to:
Close ICM,
Open ICM,
Stay in the same position, as when power failure occurs
Go to a specific ICM valve opening degree
- Hermetic magnetic motor - spindle heater not required
- Enclosure: IP65 ~ NEMA 4
- Approvals: CE (EMC)

Technical data (actuator)

ICAD 600 and ICAD 900 can be used together with following Danfoss valves.

ICAD 600	ICAD 900
ICM 20	ICM 40
ICM 25	ICM 50
ICM 32	ICM 65

Materials

Housing
Aluminium
Top part of ICAD
PBT thermo plastic

Weight

ICAD 600: 1.2 kg (2.64 lb)
ICAD 900: 1.8 kg (3.96 lb)

Temperature range (ambient)

-30°C/+50°C (-22°F/122°F)

Enclosure

IP 65 (~NEMA 4)

Cable connection

2 cable premounted of 1.8 m length (70.7 in.)

Supply cable

3 × 0.34 mm² (3 × ~22 AWG)
Ø4.4 mm (diameter 0.17")

Control cable

7 × 0.25 mm² (7 × ~24 AWG)
Ø5.2 mm (diameter 0.20")

Electrical data

Supply voltage is galvanic isolated from Input/Output.

Supply voltage: 24 V d.c., + 10% / -15%

Load: ICAD 600: 1.2 A
ICAD 900: 2.0 A

Fail safe supply: Min. 19 V d.c, max. 26.4 V d.c.

Load: ICAD 600: 1.2 A
ICAD 900: 2.0 A

Battery capacity:

For each open/closed cycle

ICAD 600: 8.3 mAh
ICAD 900: 11.1 mAh

Analogue Input - Current or Voltage

Current: 0/4-20 mA
Load: 200 Ω
Voltage: 0/2-10 V d.c
Load: 10 kΩ

Analogue Output: 0/4-20 mA

Load: ≤ 250 Ω

Digital input - Digital ON/OFF input by means of volt-free contact (Signal/Telecom relays with gold-plated contacts recommended) – Voltage input used

ON: contact impedance < 50 Ω)
OFF: contact impedance > 100 kΩ

Digital Output - 3 pcs. NPN transistor output

External supply: 5-24 V d.c.

(Same supply as for ICAD can be used, but please note that the galvanically isolated system will then be spoiled)

Output load: 50 Ω

Load: Max. 50 mA

Technical data (cont.)

Cable connection
Two 1.8 m (70.7 in.) cables premounted

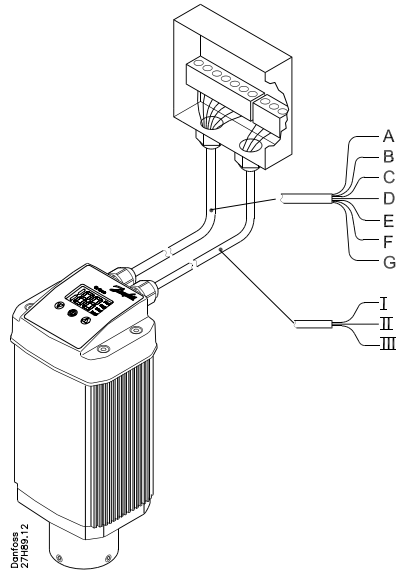

Figure 1

Ref.	Colour		Description
A	White	-	Common Alarm
B	Brown	-	ICM fully open
C	Green	-	ICM fully closed
D	Yellow	-	GND ground
E	Grey	+	0/4 - 20 mA Input
F	Pink	+	0/2 - 10 V Input
G	Blue	+	0/4 - 20 mA Output

} Digital Output

} Analogue In/Output

I	White	+	Fail safe supply Battery / UPS* 19 V d.c.
II	Brown	+	Supply voltage
III	Green	-	24 V d.c.

* Uninterruptable Power Supply

Approvals

CE according to 89/336 EEC (EMC)
Emission : EN61000-6-3
Immunity : EN61000-6-2

Function (actuator)

The design of ICAD is based on a digital stepper motor technology combined with an advanced MMI (Man Machine Interface), that gives excellent possibilities for having a high degree of flexibility with the same type of ICAD actuator.

At the ICAD display the Opening Degree (0-100 %) of the actual ICM valve installed can be continuously observed.

The advanced menu system will allow several parameters to be adjusted to obtain the required function. Many different parameters can be configured, among these:

- Modulating and ON/OFF control
- Analog input
0- 20 mA or 4-20 mA
0-10V or 2-10 V
- Analog output
0- 20 mA or 4-20 mA
- Automatic or manual control
- Change of ICM valve speed
- Automatic calibration
- Multiple Fail Safe set-up options during power cut

For service all Input and Output signals can be recalled and observed from the ICAD display.

A password protection has been linked to the parameter of entering the correct ICM valve to avoid unintentional and non-authorized operation.

ICAD can manage and display different alarms. If an alarm has been detected the display will alternate between showing: Actual alarm present and Opening Degree of ICM valve. If more than one alarm is active at the same time the alarm with the highest priority will take preference. The alarm with the highest priority is shown on the display.

All alarms will automatically reset when disappearing.

Previous alarms can be recalled for traceability and service purposes.

Any active alarm will activate the common digital alarm output. All alarms will automatically reset when disappearing.

ICAD provides two digital output signals to 3rd party control equipment (e.g. PLC) indicating if the ICM valve is completely open or completely closed.

The hermetic magnetic motor coupling makes it easy to dismount the ICAD from ICM valve.

ICAD-UPS for ICM 20-125



ICAD-UPS is dedicated for use along with ICM sizes 20-125 installed with ICAD 600 and ICAD 900 actuators.

In the event of power failure, there is a need to make sure that the ICM goes to a safe position.

ICAD-UPS can be connected to the ICAD 600/900.

The solution ICM with ICAD connected to ICAD-UPS will give one of the following possibilities in the event of power failure:

- close ICM
- open ICM
- stay
- go to a specific ICM Opening Degree

When power supply has been re-established the system will automatically return to normal operation.

Facts and features

- Industrial product.
- Can support up to
 - 5 pcs. of ICAD 900 or
 - 8 pcs. of ICAD 600
- Integrated solution - battery and UPS.
- Industrial approvals: CE, UL, GL (Germanischer Lloyd).
- DIN rail mounting.
- LED indication
 - Green (Power ON)
 - Yellow (Flashing:charging, Constant: Buffer mode (Failsafe supply to ICAD))
 - Red (Battery fully discharged/Battery faulty)
- 24 V d.c supply → Same transformer as for ICAD can be used. Only +0,5 A extra load on the transformer.
- Check of battery every 60 sec.
- Adjustable buffer time*. (1, 2, 3, 5, 10, 15, 20, 30 or infinity) = Ensures longer life time of the battery.
- Forced remote shutdown in buffer mode via digital input.
- 3 digital volt free relay change over contacts for signals to PLC systems. (Power OK, Buffer mode (failsafe supply to ICAD), Alarm).

* Buffer time is defined as the period where ICAD is only powered from the ICAD-UPS (i.e. not from main supply). On ICAD-UPS there is an adjustable buffer time setting (1, 2, 3, 5, 10, 15, 20, 30 min. or infinity). If set to 3, ICAD-UPS will switch off power to connected ICAD 600/900, 3 minutes after the power failure occurs. This ensures that the internal battery inside ICAD-UPS do not fully discharge.

Code number: **027H0182**

For further information please see the instruction PIHV0B.

ICAD-UPS applications

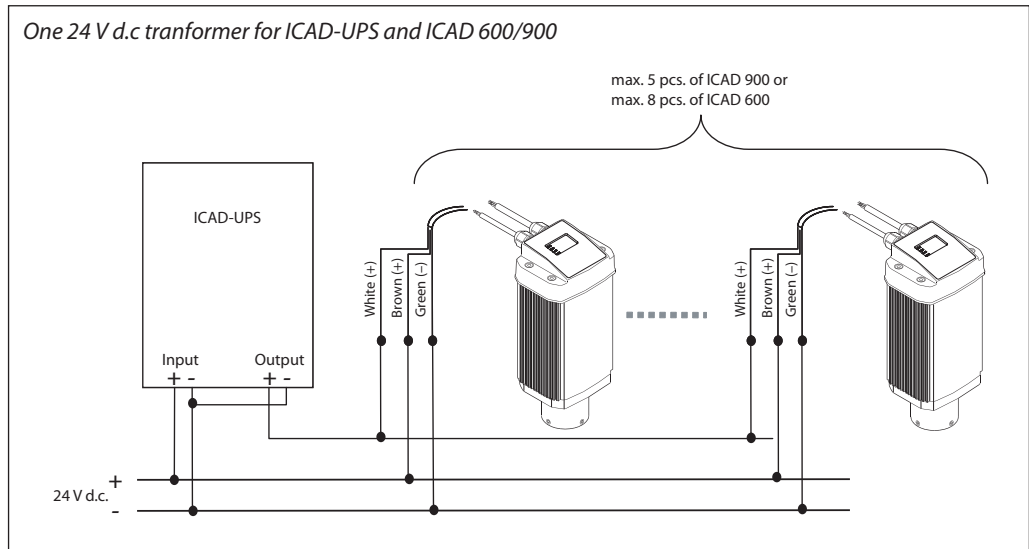
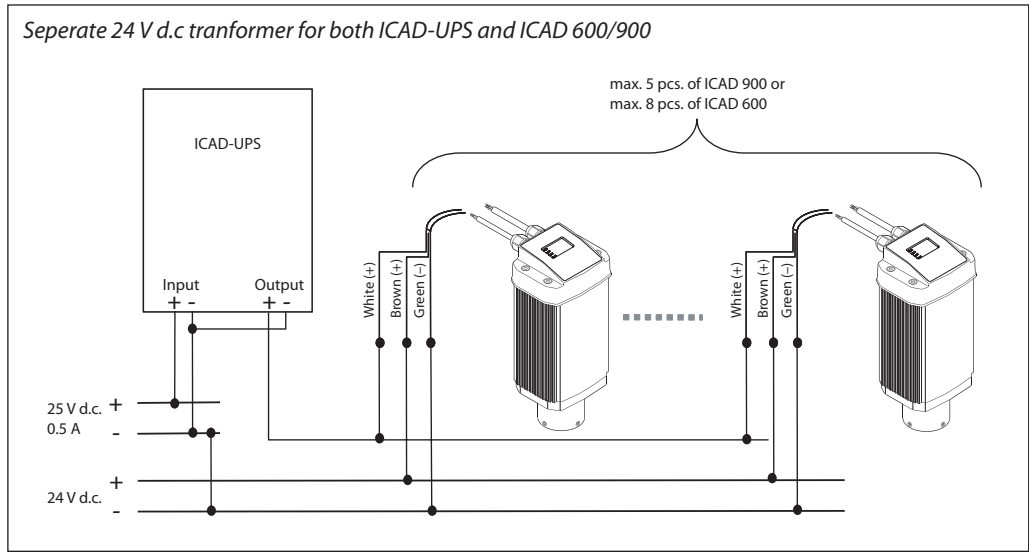

Material specification

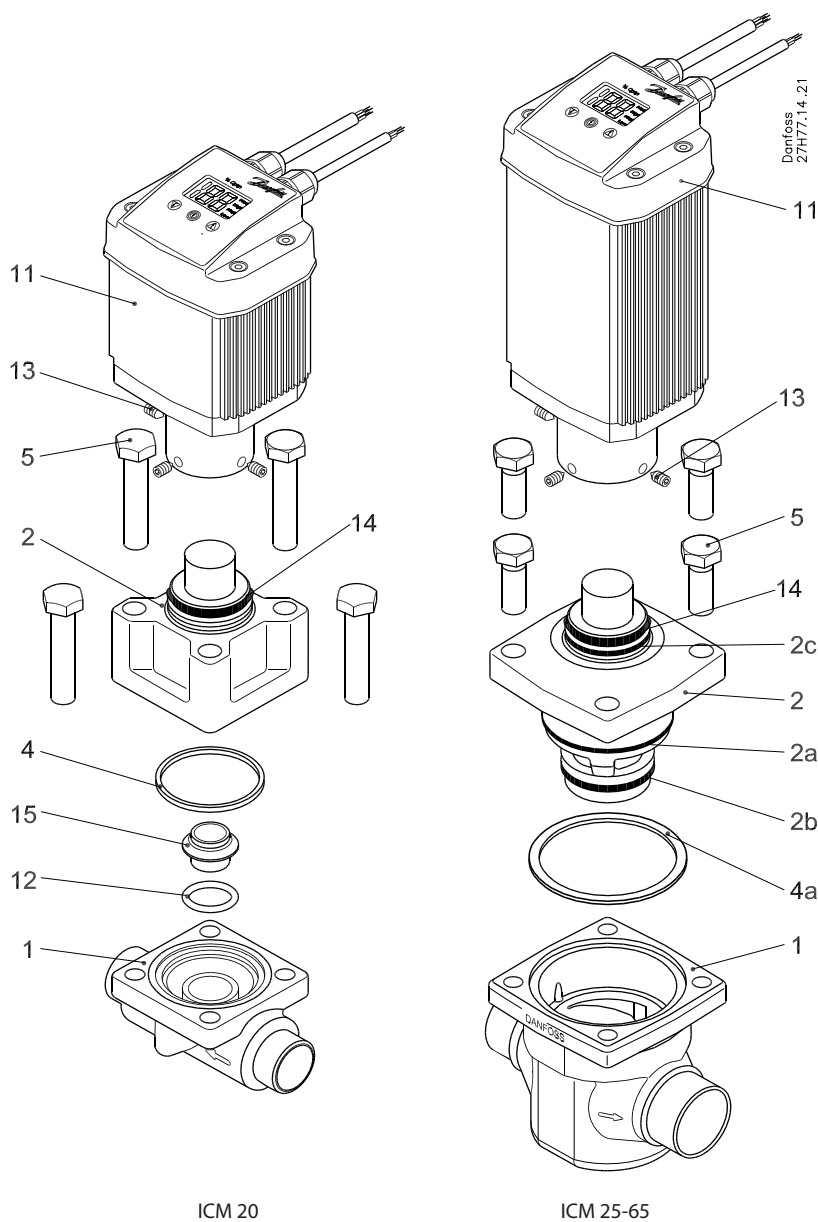

Bolt sizes (pos. 5)

Type	Screw
ICM 20	M10 × 55 A2-70 DIN 931
ICM 25	M12 × 30 A2-70 DIN 933
ICM 32	M14 × 35 A2-70 DIN 933
ICM 40	M14 × 35 A2-70 DIN 933
ICM 50	M16 × 40 A2-70 DIN 933
ICM 65	M16 × 40 A2-70 DIN 933

No.	Part	Material	EN	ASTM	JIS
1	Housing	Low temperature steel	G20Mn5QT, EN 10213-3	LCC, A352	SCPL1, G5151
2	Top cover / function module	Low temperature steel	G20Mn5QT, EN 10213-3	LCC, A352	SCPL1, G5151
2a	O-ring	Cloroprene (Neoprene)			
2b	O-ring	Cloroprene (Neoprene)			
2c	O-ring	Cloroprene (Neoprene)			
4	Gasket	Cloroprene (Neoprene)			
4a	Gasket	Fiber, non-asbestos			
5	Bolts	Stainless steel	A2-70, EN 1515-1	Grade B8 A320	A2-70, B 1054
11	Actuator				
12	O-ring	Cloroprene (Neoprene)			
13	Screw	Stainless steel			
14	O-ring	Cloroprene (Neoprene)			
15	Seat	High density polymer			

ICM Application

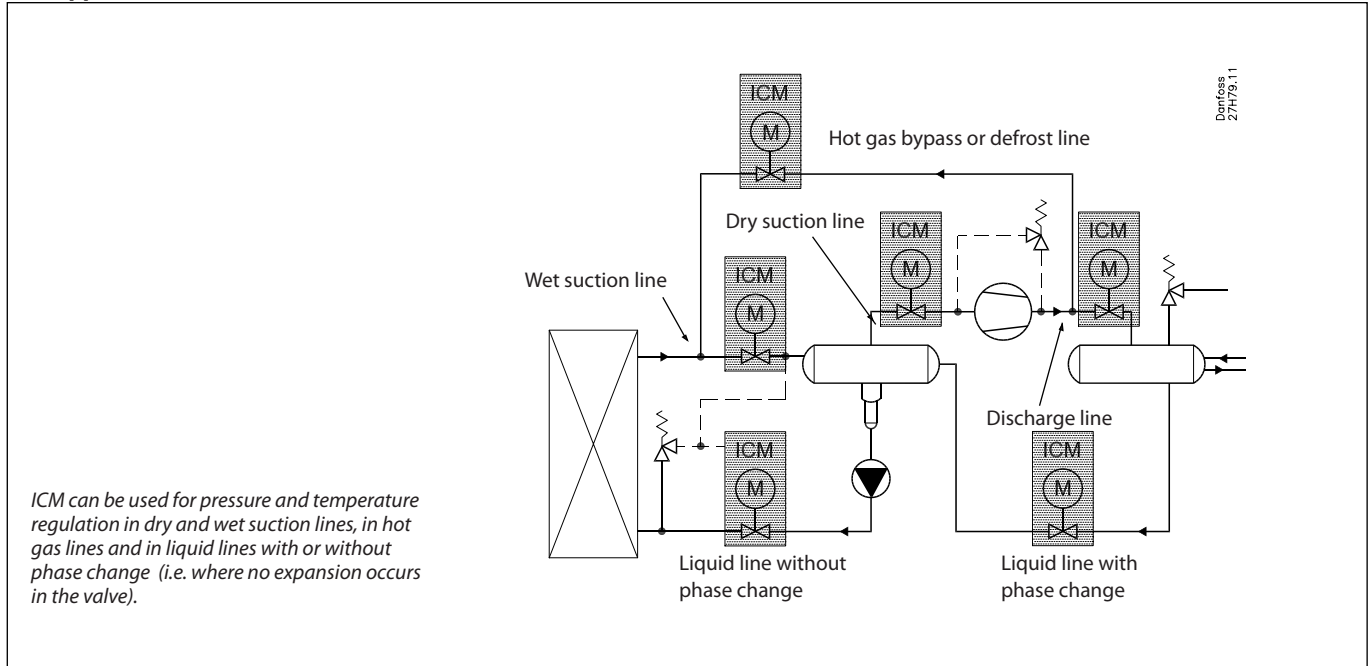

Valve capacities for different refrigerants and applications are given in the following tables. Selection of ICM / ICS valves will be available with the DIRcalc ver. 1.3 selection program and later. The resultant valve selections will be:- ICM-EXP for expansion valve functions and where the selection criteria has been predefined for expansion valve application: ICM will be for control valve functions and will include for all available function modules as valve pressure drop is the main consideration for valve selection.

As the ICM and ICS valves use a common body it is possible to install the body without having previously determined whether a servo or motor function is required. A blank top cover complete with fixing screws can be supplied to allow for pressure testing.

The process for identifying the ICM valve solution can be determined from the ordering pages. Initially select the nominal valve size, identify the required valve body and connection types, followed by the module insert and then the correct actuator to suit the module insert and valve body.

Recommended filters

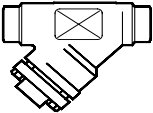
	Filter Type	Size	D	A	FPT	Soc	Filter element for liquid line		Filter element for suction line	
							150 mesh	100 mesh	72 mesh	38 mesh
							100 my	150 my	250 my	500 my
	FIA Straightway	20 (3/4 in.)	148H3086	148H3098	148H3116	148H3110	148H3122	148H3124	148H3126	148H3128
	FIA Straightway	25 (1 in.)	148H3087	148H3099	148H3117	148H3111	148H3123	148H3125	148H3127	148H3129
	FIA Straightway	32 (1 1/4 in.)	148H3088	148H3100	148H3118	148H3112	148H3123	148H3125	148H3127	148H3129
	FIA Straightway	40 (1 1/2 in.)	148H3089	148H3101		148H3113	148H3123	148H3125	148H3127	148H3129
	FIA Straightway	50 (2 in.)	148H3090	148H3102		148H3114	148H3157	148H3130	148H3138	148H3144
	FIA Straightway	65 (2 1/2 in.)	148H3091	148H3103				148H3131	148H3139	148H3145
	FIA Straightway	80 (3 in.)	148H3092	148H3104				148H3119	148H3120	148H3121

Nominal capacities

Liquid line with/without phase change

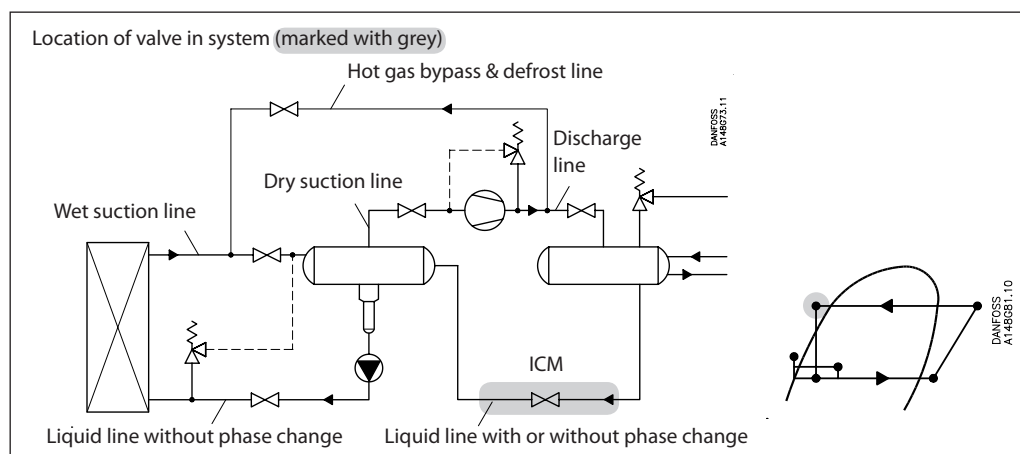

SI units

Calculation example (R717 capacities):

An application has following running conditions:

$T_e = -20^\circ\text{C}$
 $Q_o = 250 \text{ kW}$
 $T_{liq} = 10^\circ\text{C}$
 Max. $\Delta p = 0.3 \text{ bar}$
 Connection: DN20

The capacity table is based on nominal condition (pressure drop $\Delta p = 0.2 \text{ bar}$, $T_{liq} = 30^\circ\text{C}$)

Therefore the actual capacity must be corrected to nominal condition by means of correction factors.

Correction factor for $\Delta p 0.3 \text{ bar } f_{\Delta p} = 0.82$
 Correction factor for liquid temperature $f_{T_{liq}} = 0.92$

$$Q_n = Q_o \times f_{\Delta p} \times f_{T_{liq}} = 250 \times 0.82 \times 0.92 = 189 \text{ kW}$$

From the capacity table a ICM 20-B with Q_n capacity 249 kW is selected.

US units

Calculation example (R717 capacities):

An application has following running conditions:

$T_e = -20^\circ\text{F}$
 $Q_o = 130 \text{ TR}$
 $T_{liq} = 50^\circ\text{F}$
 Max. $\Delta p = 3.5 \text{ psi}$
 Connection: $3/4"$

The capacity table is based on nominal condition (pressure drop $\Delta p = 3 \text{ psi}$, $T_{liq} = 90^\circ\text{F}$)

Therefore the actual capacity must be corrected to nominal condition by means of correction factors.

Correction factor for $\Delta p 3.5 \text{ psi } f_{\Delta p} = 0.91$
 Correction factor for liquid temperature $f_{T_{liq}} = 0.92$

$$Q_n = Q_o \times f_{\Delta p} \times f_{T_{liq}} = 130 \times 0.91 \times 0.92 = 109 \text{ TR}$$

From the capacity table a ICM 20-C with Q_n capacity 134 TR is selected.

Nominal capacities

Liquid line with/without phase change

SI units

Capacity table for nominal conditions, Q_N [kW],
 $T_{liq} = 30^\circ\text{C}$,
 $\Delta P = 0.2$ bar

R 717

Type	Valve body size	K_v (m^3/h)	Evaporating temperature [$^\circ\text{C}$]							
			-50	-40	-30	-20	-10	0	10	20
ICM20-A	20	0.6	59.5	60.5	61.4	62.2	62.9	63.4	63.9	64.2
ICM20-B		2.4	238	242	245	249	251	254	256	257
ICM20-C		4.6	457	464	471	477	482	486	490	493
ICM25-A	25	6	595	605	614	622	629	634	639	642
ICM25-B		12	1191	1210	1227	1243	1257	1269	1278	1285
ICM32-A	32	9	893	907	921	933	943	952	959	964
ICM32-B		17	1687	1714	1739	1761	1781	1797	1811	1820
ICM40-A	40	15	1489	1512	1534	1554	1571	1586	1598	1606
ICM40-B		26	2580	2622	2659	2694	2724	2749	2769	2784
ICM50-A	50	23	2283	2319	2353	2383	2409	2432	2450	2463
ICM50-B		40	3970	4033	4091	4145	4190	4229	4260	4283
ICM65-B	65	70	6947	7058	7160	7253	7333	7401	7455	7495

Correction factor for liquid temperature (T_{liq})

Liquid temperature	Correction factor
-20 $^\circ\text{C}$	0.82
-10 $^\circ\text{C}$	0.86
0 $^\circ\text{C}$	0.88
10 $^\circ\text{C}$	0.92
20 $^\circ\text{C}$	0.96
30$^\circ\text{C}$	1.00
40 $^\circ\text{C}$	1.04
50 $^\circ\text{C}$	1.09

Correction factor for ΔP ($f_{\Delta P}$)

ΔP (bar)	Correction factor
0.05	2.00
0.1	1.41
0.2	1.00
0.3	0.82
0.4	0.71
0.5	0.63

US units

Capacity table for nominal conditions, Q_N [Tons of Refrigeration],
 $T_{liq} = 90^\circ\text{F}$,
 $\Delta P = 3$ psi

R 717

Type	Valve body size	C_v (USgal/min)	Evaporating temperature [$^\circ\text{F}$]							
			-60	-40	-20	0	20	40	60	80
ICM20-A	20	0.7	17.1	17.4	17.7	17.9	18.1	18.3	18.4	18.5
ICM20-B		2.8	68.3	69.5	70.7	71.7	72.5	73.2	73.7	74.0
ICM20-C		5.3	129	132	134	136	137	139	140	140
ICM25-A	25	7	171	174	177	179	181	183	184	185
ICM25-B		14	342	348	353	358	363	366	369	370
ICM32-A	32	10	244	248	252	256	259	261	263	264
ICM32-B		20	488	497	505	512	518	523	527	529
ICM40-A	40	17	415	422	429	435	440	445	448	450
ICM40-B		30	732	745	757	768	777	784	790	793
ICM50-A	50	27	659	670	681	691	699	706	711	714
ICM50-B		46	1122	1142	1161	1177	1191	1203	1211	1216
ICM65-B	65	81	1976	2011	2044	2073	2098	2118	2133	2142

Correction factor for liquid temperature (T_{liq})

Liquid temperature	Correction factor
-10 $^\circ\text{F}$	0.82
10 $^\circ\text{F}$	0.85
30 $^\circ\text{F}$	0.88
50 $^\circ\text{F}$	0.92
70 $^\circ\text{F}$	0.96
90$^\circ\text{F}$	1.00
110 $^\circ\text{F}$	1.04
130 $^\circ\text{F}$	1.09

Correction factor for ΔP ($f_{\Delta P}$)

ΔP (psi)	Correction factor
0.75	1.97
1.5	1.39
3	1.00
3.5	0.91
4	0.85
4.5	0.81

Nominal capacities

Liquid line with/without phase change

SI units

Capacity table for nominal conditions, Q_N [kW], $T_{liq} = 10^\circ\text{C}$, $\Delta P = 0.2$ bar

R 744

Type	Valve body size	K_v (m^3/h)	Evaporating temperature [$^\circ\text{C}$]							
			-50	-40	-30	-20	-10	0	10	20
ICM20-A	20	0.6	14.4	14.6	14.8	14.8	14.7	14.4	13.8	12.8
ICM20-B		2.4	57.8	58.6	59.0	59.1	58.7	57.5	55.3	51.1
ICM20-C		4.6	111	112	113	113	112	110	106	97.8
ICM25-A	25	6	144	146	148	148	147	144	138	128
ICM25-B		12	289	293	295	296	293	288	277	255
ICM32-A	32	9	217	220	221	222	220	216	207	191
ICM32-B		17	409	415	418	419	416	408	392	362
ICM40-A	40	15	361	366	369	369	367	360	346	319
ICM40-B		26	626	634	640	640	636	623	599	553
ICM50-A	50	23	554	561	566	566	562	551	530	489
ICM50-B		40	963	976	984	985	978	959	922	851
ICM65-B	65	70	1685	1708	1722	1724	1711	1678	1613	1489

Correction factor for ΔP ($f_{\Delta P}$)

ΔP (bar)	Correction factor
0.05	2.00
0.1	1.41
0.2	1.00
0.3	0.82
0.4	0.71
0.5	0.63

Correction factor for liquid temperature (T_{liq})

Liquid temperature	Correction factor
-20 $^\circ\text{C}$	0.52
-10 $^\circ\text{C}$	0.67
0 $^\circ\text{C}$	0.91
10$^\circ\text{C}$	1.00
15 $^\circ\text{C}$	1.09

US units

Capacity table for nominal conditions, Q_N [Tons of Refrigeration], $T_{liq} = 50^\circ\text{F}$, $\Delta P = 3$ psi

R 744

Type	Valve body size	C_v (USgal/min)	Evaporating temperature [$^\circ\text{F}$]							
			-60	-40	-20	0	20	40	60	
ICM20-A	20	0.7	4.2	4.2	4.3	4.3	4.2	4.1	3.9	
ICM20-B		2.8	16.7	17.0	17.1	17.1	16.9	16.5	15.5	
ICM20-C		5.3	31.7	32.2	32.5	32.5	32.1	31.1	29.3	
ICM25-A	25	7	41.8	42.5	42.9	42.9	42.3	41.1	38.7	
ICM25-B		14	83.7	85.0	85.7	85.7	84.7	82.3	77.3	
ICM32-A	32	10	59.8	60.7	61.2	61.2	60.5	58.8	55.2	
ICM32-B		20	120	121	122	122	121	118	110	
ICM40-A	40	17	102	103	104	104	103	100	94	
ICM40-B		30	179	182	184	184	181	176	166	
ICM50-A	50	27	161	164	165	165	163	159	149	
ICM50-B		46	275	279	282	282	278	270	254	
ICM65-B	65	81	484	492	496	496	490	476	448	

Correction factor for ΔP ($f_{\Delta P}$)

ΔP (psi)	Correction factor
0.75	1.97
1.5	1.39
3	1.00
3.5	0.91
4	0.85
4.5	0.81

Correction factor for liquid temperature (T_{liq})

Liquid temperature	Correction factor
-10 $^\circ\text{F}$	0.48
10 $^\circ\text{F}$	0.64
30 $^\circ\text{F}$	0.88
50$^\circ\text{F}$	1.00

Nominal capacities

Liquid line with/without phase change

SI units

Capacity table for nominal conditions, Q_N [kW],
 $T_{liq} = 30^\circ\text{C}$,
 $\Delta P = 0.2$ bar

R 134a

Type	Valve body size	K_v (m^3/h)	Evaporating temperature [$^\circ\text{C}$]						
			-40	-30	-20	-10	0	10	20
ICM20-A	20	0.6	10.7	11.2	11.7	12.2	12.7	13.1	13.6
ICM20-B		2.4	42.7	44.7	46.7	48.7	50.6	52.5	54.2
ICM20-C		4.6	81.9	85.8	89.6	93.3	97.0	101	104
ICM25-A	25	6	107	112	117	122	127	131	136
ICM25-B		12	214	224	234	243	253	262	271
ICM32-A	32	9	160	168	175	183	190	197	203
ICM32-B		17	303	317	331	345	358	372	384
ICM40-A	40	15	267	280	292	304	316	328	339
ICM40-B		26	463	485	506	527	548	568	588
ICM50-A	50	23	409	429	448	467	485	503	520
ICM50-B		40	712	746	779	811	843	874	904
ICM65-B	65	70	1246	1305	1363	1420	1476	1530	1582

Correction factor for liquid temperature (T_{liq})

Liquid temperature	Correction factor
-20 $^\circ\text{C}$	0.66
-10 $^\circ\text{C}$	0.70
0 $^\circ\text{C}$	0.76
10 $^\circ\text{C}$	0.82
20 $^\circ\text{C}$	0.90
30$^\circ\text{C}$	1.00
40 $^\circ\text{C}$	1.13
50 $^\circ\text{C}$	1.29

Correction factor for ΔP ($f_{\Delta P}$)

ΔP (bar)	Correction factor
0.05	2.00
0.1	1.41
0.2	1.00
0.3	0.82
0.4	0.71
0.5	0.63

US units

Capacity table for nominal conditions, Q_N [Tons of Refrigeration],
 $T_{liq} = 90^\circ\text{F}$,
 $\Delta P = 3$ psi

R 134a

Type	Valve body size	C_v (USgal/min)	Evaporating temperature [$^\circ\text{F}$]						
			-40	-20	0	20	40	60	80
ICM20-A	20	0.7	3.0	3.2	3.3	3.5	3.7	3.8	3.9
ICM20-B		2.8	12.1	12.7	13.4	14.0	14.6	15.2	15.8
ICM20-C		5.3	22.9	24.1	25.3	26.5	27.7	28.8	29.8
ICM25-A	25	7	30.2	31.8	33.4	35.0	36.6	38.0	39.4
ICM25-B		14	60.4	63.7	66.9	70.1	73.1	76.0	78.8
ICM32-A	32	10	43.1	45.5	47.8	50.1	52.2	54.3	56.3
ICM32-B		20	86.3	91.0	95.6	100	104	109	113
ICM40-A	40	17	73.4	77.3	81.2	85.1	88.8	92.3	95.7
ICM40-B		30	129	136	143	150	157	163	169
ICM50-A	50	27	117	123	129	135	141	147	152
ICM50-B		46	198	209	220	230	240	250	259
ICM65-B	65	81	350	369	387	406	423	440	456

Correction factor for liquid temperature (T_{liq})

Liquid temperature	Correction factor
-10 $^\circ\text{F}$	0.64
10 $^\circ\text{F}$	0.68
30 $^\circ\text{F}$	0.74
50 $^\circ\text{F}$	0.81
70 $^\circ\text{F}$	0.89
90$^\circ\text{F}$	1.00
110 $^\circ\text{F}$	1.15
130 $^\circ\text{F}$	1.35

Correction factor for ΔP ($f_{\Delta P}$)

ΔP (psi)	Correction factor
0.75	1.97
1.5	1.39
3	1.00
3.5	0.91
4	0.85
4.5	0.81

Nominal capacities

Liquid line with/without phase change

SI units

Capacity table for nominal conditions, Q_N [kW],
 $T_{liq} = 30^\circ\text{C}$,
 $\Delta P = 0.2$ bar

R 404A

Type	Valve body size	K_v (m ³ /h)	Evaporating temperature [°C]							
			-50	-40	-30	-20	-10	0	10	20
ICM20-A	20	0.6	6.9	7.4	7.9	8.3	8.8	9.2	9.6	10.0
ICM20-B		2.4	27.7	29.6	31.5	33.4	35.2	36.9	38.5	39.9
ICM20-C		4.6	53.0	56.7	60.4	64.0	67.5	70.8	73.8	76.5
ICM25-A	25	6	69.2	74.0	78.8	83.5	88.0	92.3	96.3	100
ICM25-B		12	138	148	158	167	176	185	193	200
ICM32-A	32	9	104	111	118	125	132	138	144	150
ICM32-B		17	196	210	223	237	249	262	273	283
ICM40-A	40	15	173	185	197	209	220	231	241	249
ICM40-B		26	300	321	341	362	381	400	417	432
ICM50-A	50	23	265	284	302	320	337	354	369	382
ICM50-B		40	461	493	525	557	587	615	642	665
ICM65-B	65	70	807	863	919	974	1027	1077	1123	1164

Correction factor for liquid temperature (T_{liq})

Liquid temperature	Correction factor
-20°C	0.55
-10°C	0.60
0°C	0.66
10°C	0.74
20°C	0.85
30°C	1.00
40°C	1.23
50°C	1.68

Correction factor for ΔP ($f_{\Delta P}$)

ΔP (bar)	Correction factor
0.05	2.00
0.1	1.41
0.2	1.00
0.3	0.82
0.4	0.71
0.5	0.63

US units

Capacity table for nominal conditions, Q_N [Tons of Refrigeration],
 $T_{liq} = 90^\circ\text{F}$,
 $\Delta P = 3$ psi

R 404A

Type	Valve body size	C_v (USgal/min)	Evaporating temperature [°F]							
			-60	-40	-20	0	20	40	60	80
ICM20-A	20	0.7	1.9	2.1	2.2	2.4	2.5	2.6	2.8	2.9
ICM20-B		2.8	7.6	8.2	8.8	9.5	10.0	10.6	11.0	11.4
ICM20-C		5.3	14.4	15.6	16.8	17.9	19.0	20.0	20.9	21.7
ICM25-A	25	7	19.0	20.6	22.1	23.6	25.1	26.4	27.6	28.6
ICM25-B		14	38.0	41.1	44.2	47.3	50.1	52.8	55.2	57.2
ICM32-A	32	10	27.2	29.4	31.6	33.8	35.8	37.7	39.4	40.9
ICM32-B		20	54.3	58.8	63.2	67.5	71.6	75.5	78.9	81.7
ICM40-A	40	17	46.2	50.0	53.7	57.4	60.9	64.1	67.1	69.5
ICM40-B		30	81.5	88.1	94.8	101	107	113	118	123
ICM50-A	50	27	73.3	79.3	85.3	91.2	96.7	102	107	110
ICM50-B		46	125	135	145	155	165	174	181	188
ICM65-B	65	81	220	238	256	274	290	306	320	331

Correction factor for liquid temperature (T_{liq})

Liquid temperature	Correction factor
-10°F	0.52
10°F	0.57
30°F	0.63
50°F	0.72
70°F	0.83
90°F	1.00
110°F	1.29
130°F	1.92

Correction factor for ΔP ($f_{\Delta P}$)

ΔP (psi)	Correction factor
0.75	1.97
1.5	1.39
3	1.00
3.5	0.91
4	0.85
4.5	0.81

Nominal capacities

Liquid line with/without phase change

SI units

Capacity table for nominal conditions, Q_N [kW],
 $T_{liq} = 30^\circ\text{C}$,
 $\Delta P = 0.2$ bar

R 22

Type	Valve body size	K_v (m ³ /h)	Evaporating temperature [°C]							
			-50	-40	-30	-20	-10	0	10	20
ICM20-A	20	0.6	11.9	12.3	12.7	13.0	13.3	13.6	13.9	14.2
ICM20-B		2.4	47.6	49.1	50.6	52.0	53.3	54.5	55.7	56.7
ICM20-C		4.6	91.3	94.2	97.0	100	102	105	107	109
ICM25-A	25	6	119	123	127	130	133	136	139	142
ICM25-B		12	238	246	253	260	267	273	278	283
ICM32-A	32	9	179	184	190	195	200	205	209	213
ICM32-B		17	337	348	358	368	378	386	394	401
ICM40-A	40	15	298	307	316	325	333	341	348	354
ICM40-B		26	516	532	548	563	578	591	603	614
ICM50-A	50	23	456	471	485	498	511	523	534	543
ICM50-B		40	794	819	843	866	889	909	928	945
ICM65-B	65	70	1389	1433	1476	1516	1555	1591	1624	1653

Correction factor for liquid temperature (T_{liq})

Liquid temperature	Correction factor
-20°C	0.71
-10°C	0.75
0°C	0.80
10°C	0.86
20°C	0.92
30°C	1.00
40°C	1.09
50°C	1.22

Correction factor for ΔP ($f_{\Delta P}$)

ΔP (bar)	Correction factor
0.2	1.00
0.25	0.89
0.3	0.82
0.4	0.71
0.5	0.63
0.6	0.58

US units

Capacity table for nominal conditions, Q_N [Tons of Refrigeration],
 $T_{liq} = 90^\circ\text{F}$,
 $\Delta P = 3$ psi

R 22

Type	Valve body size	C_v (USgal/min)	Evaporating temperature [°F]							
			-60	-40	-20	0	20	40	60	80
ICM20-A	20	0.7	3.4	3.5	3.6	3.7	3.8	3.9	4.0	4.1
ICM20-B		2.8	13.5	14.0	14.4	14.9	15.3	15.7	16.0	16.3
ICM20-C		5.3	25.5	26.4	27.4	28.2	29.0	29.7	30.4	30.9
ICM25-A	25	7	33.7	34.9	36.1	37.2	38.3	39.2	40.1	40.8
ICM25-B		14	67.4	69.8	72.2	74.5	76.6	78.5	80.2	81.6
ICM32-A	32	10	48.1	49.9	51.6	53.2	54.7	56.0	57.3	58.3
ICM32-B		20	96.3	100	103	106	109	112	115	117
ICM40-A	40	17	81.9	84.8	87.7	90.5	93.0	95.3	97.4	99.1
ICM40-B		30	144	150	155	160	164	168	172	175
ICM50-A	50	27	130	135	139	144	148	151	155	157
ICM50-B		46	221	229	237	245	252	258	264	268
ICM65-B	65	81	390	404	418	431	443	454	464	472

Correction factor for liquid temperature (T_{liq})

Liquid temperature	Correction factor
-10°F	0.73
10°F	0.77
30°F	0.82
50°F	0.87
70°F	0.93
90°F	1.00
110°F	1.09
130°F	1.20

Correction factor for ΔP ($f_{\Delta P}$)

ΔP (psi)	Correction factor
3	1.00
4	0.87
5	0.79
6	0.72
7	0.66
8	0.62

Nominal capacities

Liquid line without phase change

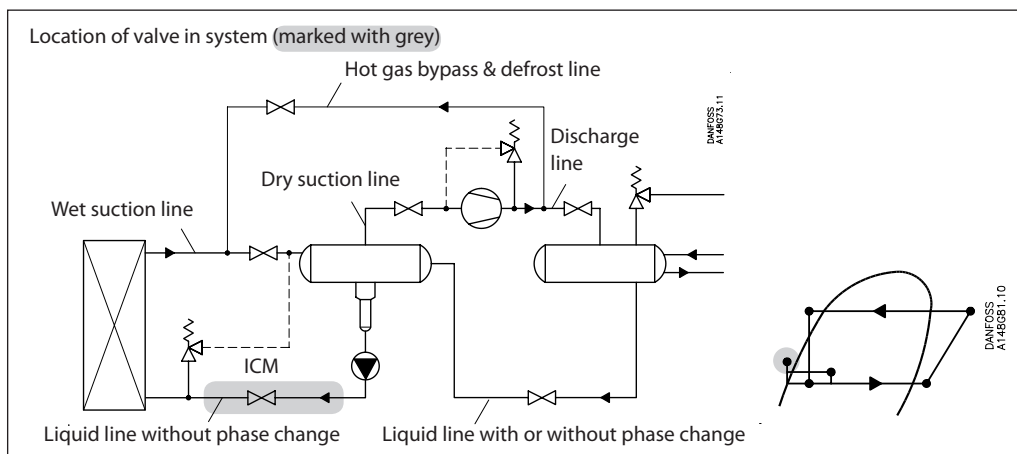

SI units

Calculation example (R717 capacities):

An application has following running conditions:

- $T_e = -20^{\circ}\text{C}$
- $Q_o = 180 \text{ kW}$
- Circulation rate = 3
- Max. $\Delta p = 0.3 \text{ bar}$
- Connection: DN20

Therefore the actual capacity must be corrected to nominal condition by means of correction factors.

- Correction factor for Δp 0.3 bar $f_{\Delta p} = 0.82$
- Correction factor for circulation rate $f_{rec} = 0.75$

$$Q_n = Q_o \times f_{\Delta p} \times f_{rec} = 180 \times 0.82 \times 0.75 = 111 \text{ kW}$$

The capacity table is based on nominal condition (pressure drop $\Delta p = 0.2 \text{ bar}$, circulation rate = 4)

From the capacity table a ICM 20-C with Q_n capacity 153 kW is selected.

US units

Calculation example (R717 capacities):

An application has following running conditions:

- $T_e = -20^{\circ}\text{F}$
- $Q_o = 130 \text{ TR}$
- Circulation rate = 3
- Max. $\Delta p = 3.5 \text{ psi}$
- Connection: 1 1/4"

Therefore the actual capacity must be corrected to nominal condition by means of correction factors.

- Correction factor for Δp 3.5 psi $f_{\Delta p} = 0.91$
- Correction factor for circulation rate $f_{rec} = 0.75$

$$Q_n = Q_o \times f_{\Delta p} \times f_{rec} = 130 \times 0.91 \times 0.75 = 89 \text{ TR}$$

The capacity table is based on nominal condition (pressure drop $\Delta p = 3 \text{ psi}$, circulation rate = 4)

From the capacity table a ICM 32-B with Q_n capacity 171 TR is selected.

Nominal capacities

Liquid line without phase change

SI units

Capacity table at nominal conditions, Q_N [kW], Circulation rate = 4, $\Delta p = 0.2$ bar

R 717

Type	Valve body size	K_v (m ³ /h)	Evaporating temperature [°C]							
			-50	-40	-30	-20	-10	0	10	20
ICM20-A	20	0.6	21.9	21.3	20.7	20.0	19.3	18.5	17.8	16.9
ICM20-B		2.4	87.6	85.2	82.7	80.0	77.1	74.2	71.0	67.8
ICM20-C		4.6	168	163	159	153	148	142	136	130
ICM25-A	25	6	219	213	207	200	193	185	178	169
ICM25-B		12	438	426	413	400	386	371	355	339
ICM32-A	32	9	329	320	310	300	289	278	266	254
ICM32-B		17	621	604	586	567	546	525	503	480
ICM40-A	40	15	548	533	517	500	482	464	444	424
ICM40-B		26	949	923	896	867	836	803	770	734
ICM50-A	50	23	840	817	793	767	739	711	681	650
ICM50-B		40	1460	1421	1378	1333	1286	1236	1184	1130
ICM65-B	65	70	2555	2486	2412	2333	2250	2163	2072	1977

Correction factor for ΔP ($f_{\Delta P}$)

ΔP (bar)	Correction factor
0.05	2.00
0.1	1.41
0.2	1.00
0.3	0.82
0.4	0.71
0.5	0.63

Correction factor for circulation rate (f_{rec})

Circulation rate	Correction factor
2	0.5
3	0.75
4	1
6	1.5
8	2
10	2.5

US units

Capacity table at nominal conditions, Q_N [Tons of Refrigeration], Circulation rate = 4, $\Delta p = 3$ psi

R 717

Type	Valve body size	C_v (USgal/min)	Evaporating temperature [°F]							
			-60	-40	-20	0	20	40	60	80
ICM20-A	20	0.7	6.4	6.2	6.0	5.8	5.5	5.3	5.0	4.8
ICM20-B		2.8	25.6	24.8	24.0	23.1	22.2	21.2	20.2	19.1
ICM20-C		5.3	48.4	46.9	45.3	43.7	41.9	40.1	38.1	36.1
ICM25-A	25	7	64.0	62.0	59.9	57.7	55.4	53.0	50.4	47.7
ICM25-B		14	128	124	120	115	111	106	101	95.4
ICM32-A	32	10	91.4	88.5	85.6	82.5	79.1	75.7	72.0	68.1
ICM32-B		20	183	177	171	165	158	151	144	136
ICM40-A	40	17	155	150	145	140	135	129	122	116
ICM40-B		30	274	266	257	247	237	227	216	204
ICM50-A	50	27	247	239	231	223	214	204	194	184
ICM50-B		46	420	407	394	379	364	348	331	313
ICM65-B	65	81	740	717	693	668	641	613	583	552

Correction factor for ΔP ($f_{\Delta P}$)

ΔP (psi)	Correction factor
0.75	1.97
1.5	1.39
3	1.00
3.5	0.91
4	0.85
4.5	0.81

Correction factor for circulation rate (f_{rec})

Circulation rate	Correction factor
2	0.5
3	0.75
4	1
6	1.5
8	2
10	2.5

Nominal capacities

Liquid line without phase change

SI units

Capacity table at nominal conditions, Q_N [kW], Circulation rate = 4, $\Delta p = 0.2$ bar

R 744

Type	Valve body size	K_v (m ³ /h)	Evaporating temperature [°C]						
			-50	-40	-30	-20	-10	0	10
ICM20-A	20	0.6	6.7	6.3	5.9	5.4	4.8	4.2	3.4
ICM20-B		2.4	27.0	25.3	23.5	21.5	19.2	16.7	13.7
ICM20-C		4.6	51.7	48.5	45.0	41.1	36.8	32.0	26.4
ICM25-A	25	6	67.5	63.3	58.7	53.7	48.0	41.7	34.4
ICM25-B		12	134.9	126.5	117.4	107.3	96.0	83.5	68.7
ICM32-A	32	9	101.2	94.9	88.1	80.5	72.0	62.6	51.6
ICM32-B		17	191	179	166	152	136	118	97.4
ICM40-A	40	15	169	158	147	134	120	104	85.9
ICM40-B		26	292	274	254	233	208	181	149
ICM50-A	50	23	259	242	225	206	184	160	132
ICM50-B		40	450	422	391	358	320	278	229
ICM65-B	65	70	787	738	685	626	560	487	401

Correction factor for ΔP ($f_{\Delta P}$)

ΔP (bar)	Correction factor
0.05	2.00
0.1	1.41
0.2	1.00
0.3	0.82
0.4	0.71
0.5	0.63

Correction factor for circulation rate (f_{rec})

Circulation rate	Correction factor
2	0.77
3	0.90
4	1
6	1.13
8	1.20
10	1.25

US units

Capacity table at nominal conditions, Q_N [Tons of Refrigeration], Circulation rate = 4, $\Delta p = 3$ psi

R 744

Type	Valve body size	C_v (USgal/min)	Evaporating temperature [°F]						
			-60	-40	-20	0	20	40	60
ICM20-A	20	0.7	2.0	1.8	1.7	1.5	1.3	1.1	0.9
ICM20-B		2.8	7.9	7.4	6.8	6.1	5.4	4.5	3.4
ICM20-C		5.3	15.0	13.9	12.8	11.6	10.1	8.5	6.5
ICM25-A	25	7	19.8	18.4	16.9	15.3	13.4	11.2	8.6
ICM25-B		14	39.5	36.8	33.9	30.5	26.8	22.5	17.2
ICM32-A	32	10	28.2	26.3	24.2	21.8	19.1	16.1	12.3
ICM32-B		20	56.4	52.6	48.4	43.6	38.3	32.1	24.6
ICM40-A	40	17	48.0	44.7	41.1	37.1	32.5	27.3	20.9
ICM40-B		30	84.7	78.9	72.6	65.4	57.4	48.2	37.0
ICM50-A	50	27	76.2	71.0	65.3	58.9	51.7	43.4	33.3
ICM50-B		46	130	121	111	100	88.0	73.9	56.7
ICM65-B	65	81	229	213	196	177	155	130	100

Correction factor for ΔP ($f_{\Delta P}$)

ΔP (psi)	Correction factor
0.75	1.97
1.5	1.39
3	1.00
3.5	0.91
4	0.85
4.5	0.81

Correction factor for circulation rate (f_{rec})

Circulation rate	Correction factor
2	0.5
3	0.75
4	1
6	1.5
8	2
10	2.5

Nominal capacities

Liquid line without phase change

SI units

Capacity table at nominal conditions, Q_N [kW], Circulation rate = 4, $\Delta p = 0.2$ bar

R 134a

Type	Valve body size	K_v (m ³ /h)	Evaporating temperature [°C]						
			-40	-30	-20	-10	0	10	20
ICM20-A	20	0.6	4.9	4.8	4.6	4.4	4.2	4.0	3.7
ICM20-B		2.4	19.8	19.1	18.3	17.6	16.7	15.9	14.9
ICM20-C		4.6	37.9	36.6	35.2	33.6	32.1	30.4	28.7
ICM25-A	25	6	49.5	47.7	45.9	43.9	41.8	39.7	37.4
ICM25-B		12	98.9	95.5	91.7	87.8	83.7	79.4	74.7
ICM32-A	32	9	74.2	71.6	68.8	65.8	62.7	59.5	56.1
ICM32-B		17	140	135	130	124	119	112	106
ICM40-A	40	15	124	119	115	110	105	99.2	93.4
ICM40-B		26	214	207	199	190	181	172	162
ICM50-A	50	23	190	183	176	168	160	152	143
ICM50-B		40	330	318	306	293	279	265	249
ICM65-B	65	70	577	557	535	512	488	463	436

Correction factor for ΔP ($f_{\Delta P}$)

ΔP (bar)	Correction factor
0.2	1.00
0.25	0.89
0.3	0.82
0.4	0.71
0.5	0.63
0.6	0.58

Correction factor for circulation rate (f_{rec})

Circulation rate	Correction factor
2	0.5
3	0.75
4	1
6	1.5
8	2
10	2.5

US units

Capacity table at nominal conditions, Q_N [Tons of Refrigeration], Circulation rate = 4, $\Delta p = 3$ psi

R 134a

Type	Valve body size	C_v (USgal/min)	Evaporating temperature [°F]						
			-40	-20	-0	20	40	60	80
ICM20-A	20	0.7	1.4	1.4	1.3	1.3	1.2	1.1	1.0
ICM20-B		2.8	5.8	5.5	5.3	5.0	4.8	4.5	4.2
ICM20-C		5.3	10.9	10.5	10.0	9.5	9.0	8.5	7.9
ICM25-A	25	7	14.4	13.8	13.2	12.6	11.9	11.2	10.4
ICM25-B		14	28.8	27.7	26.4	25.1	23.8	22.4	20.8
ICM32-A	32	10	20.6	19.8	18.9	18.0	17.0	16.0	14.9
ICM32-B		20	41.1	39.5	37.8	35.9	34.0	32.0	29.8
ICM40-A	40	17	35.0	33.6	32.1	30.5	28.9	27.2	25.3
ICM40-B		30	61.7	59.3	56.7	53.9	51.0	48.0	44.6
ICM50-A	50	27	55.5	53.3	51.0	48.5	45.9	43.2	40.2
ICM50-B		46	94.6	90.9	86.9	82.6	78.2	73.5	68.4
ICM65-B	65	81	167	160	153	146	138	130	121

Correction factor for ΔP ($f_{\Delta P}$)

ΔP (psi)	Correction factor
3	1.00
4	0.87
5	0.79
6	0.72
7	0.66
8	0.62

Correction factor for circulation rate (f_{rec})

Circulation rate	Correction factor
2	0.5
3	0.75
4	1
6	1.5
8	2
10	2.5

Nominal capacities

Liquid line without phase change

SI units

Capacity table at nominal conditions, Q_N [kW], Circulation rate = 4, $\Delta p = 0.2$ bar

R 404A

Type	Valve body size	K_v (m ³ /h)	Evaporating temperature [°C]							
			-50	-40	-30	-20	-10	0	10	20
ICM20-A	20	0.6	4.4	4.2	4.0	3.8	5.3	3.4	3.1	2.9
ICM20-B		2.4	17.5	16.7	15.9	15.1	21.2	13.5	12.5	11.5
ICM20-C		4.6	33.4	32.1	30.4	29.0	40.6	25.8	24.0	21.9
ICM25-A	25	6	43.6	41.8	39.7	37.8	53.0	33.7	31.3	28.6
ICM25-B		12	87.3	83.7	79.4	75.6	105.9	67.4	62.6	57.3
ICM32-A	32	9	65.4	62.7	59.5	56.7	79.5	50.5	46.9	42.9
ICM32-B		17	124	119	112	107	150	95.4	88.6	81.1
ICM40-A	40	15	109	105	99.2	94.5	132.4	84.2	78.2	71.6
ICM40-B		26	189	181	172	164	230	146	136	124
ICM50-A	50	23	167	160	152	145	203	129	120	110
ICM50-B		40	291	279	265	252	353	225	209	191
ICM65-B	65	70	509	488	463	441	618	393	365	334

Correction factor for ΔP ($f_{\Delta P}$)

ΔP (bar)	Correction factor
0.05	2.00
0.1	1.41
0.2	1.00
0.3	0.82
0.4	0.71
0.5	0.63

Correction factor for circulation rate (f_{rec})

Circulation rate	Correction factor
2	0.5
3	0.75
4	1
6	1.5
8	1.2
10	2.5

US units

Capacity table at nominal conditions, Q_N [Tons of Refrigeration], Circulation rate = 4, $\Delta p = 3$ psi

R 404A

Type	Valve body size	C_v (USgal/min)	Evaporating temperature [°F]							
			-60	-40	-20	0	20	40	60	80
ICM20-A	20	0.7	1.3	1.2	1.1	1.1	1.0	1.0	0.9	0.8
ICM20-B		2.8	5.1	4.9	4.6	4.4	4.1	3.8	3.5	3.1
ICM20-C		5.3	9.7	9.2	8.7	8.2	7.7	7.2	6.6	5.9
ICM25-A	25	7	12.7	12.2	11.5	10.9	10.2	9.5	8.7	7.8
ICM25-B		14	25.5	24.4	23.0	21.8	20.4	19.0	17.4	15.5
ICM32-A	32	10	18.2	17.4	16.4	15.6	14.6	13.6	12.4	11.1
ICM32-B		20	36.4	34.8	32.8	31.1	29.2	27.2	24.8	22.2
ICM40-A	40	17	31.0	29.6	27.9	26.4	24.8	23.1	21.1	18.8
ICM40-B		30	54.6	52.2	49.3	46.7	43.8	40.7	37.2	33.3
ICM50-A	50	27	49.2	47.0	44.3	42.0	39.4	36.7	33.5	29.9
ICM50-B		46	83.8	80.1	75.5	71.6	67.2	62.5	57.1	51.0
ICM65-B	65	81	148	141	133	126	118	110	101	89.8

Correction factor for ΔP ($f_{\Delta P}$)

ΔP (psi)	Correction factor
0.75	1.97
1.5	1.39
3	1.00
3.5	0.91
4	0.85
4.5	0.81

Correction factor for circulation rate (f_{rec})

Circulation rate	Correction factor
2	0.5
3	0.75
4	1
6	1.5
8	2
10	2.5

Nominal capacities

Liquid line without phase change

SI units

Capacity table at nominal conditions, Q_N [kW], Circulation rate = 4, $\Delta p = 0.2$ bar

R 22

Type	Valve body size	K_v (m ³ /h)	Evaporating temperature [°C]							
			-50	-40	-30	-20	-10	0	10	20
ICM20-A	20	0.6	5.3	5.2	5.0	4.8	4.6	4.3	4.1	3.9
ICM20-B		2.4	21.4	20.6	19.9	19.1	18.2	17.3	16.4	15.4
ICM20-C		4.6	40.9	39.6	38.1	36.5	35.0	33.3	31.5	29.6
ICM25-A	25	6	53.4	51.6	49.7	47.7	45.6	43.4	41.1	38.6
ICM25-B		12	107	103	99.4	95.3	91.2	86.7	82.1	77.1
ICM32-A	32	9	80.1	77.4	74.6	71.5	68.4	65.1	61.6	57.9
ICM32-B		17	151	146	141	135	129	123	116	109
ICM40-A	40	15	134	129	124	119	114	108	103	96
ICM40-B		26	231	224	215	207	198	188	178	167
ICM50-A	50	23	205	198	191	183	175	166	157	148
ICM50-B		40	356	344	331	318	304	289	274	257
ICM65-B	65	70	623	602	580	556	532	506	479	450

Correction factor for ΔP ($f_{\Delta P}$)

ΔP (bar)	Correction factor
0.2	1.00
0.25	0.89
0.3	0.82
0.4	0.71
0.5	0.63
0.6	0.58

Correction factor for circulation rate (f_{rec})

Circulation rate	Correction factor
2	0.5
3	0.75
4	1
6	1.5
8	2
10	2.5

US units

Capacity table at nominal conditions, Q_N [Tons of Refrigeration], Circulation rate = 4, $\Delta p = 3$ psi

R 22

Type	Valve body size	C_v (USgal/min)	Evaporating temperature [°F]							
			-60	-40	-20	0	20	40	60	80
ICM20-A	20	0.7	1.6	1.5	1.4	1.4	1.3	1.2	1.2	1.1
ICM20-B		2.8	6.2	6.0	5.8	5.5	5.2	4.9	4.6	4.3
ICM20-C		5.3	11.8	11.4	10.9	10.4	9.9	9.3	8.7	8.1
ICM25-A	25	7	15.6	15.0	14.4	13.7	13.1	12.3	11.6	10.7
ICM25-B		14	31.2	30.1	28.8	27.5	26.1	24.7	23.1	21.4
ICM32-A	32	10	22.3	21.5	20.6	19.6	18.7	17.6	16.5	15.3
ICM32-B		20	44.6	43.0	41.2	39.3	37.3	35.2	33.0	30.6
ICM40-A	40	17	37.9	36.5	35.0	33.4	31.7	29.9	28.1	26.0
ICM40-B		30	66.9	64.4	61.7	58.9	56.0	52.9	49.5	45.9
ICM50-A	50	27	60.2	58.0	55.6	53.0	50.4	47.6	44.6	41.3
ICM50-B		46	103	98.8	94.7	90.4	85.8	81.0	75.9	70.4
ICM65-B	65	81	181	174	167	159	151	143	134	124

Correction factor for ΔP ($f_{\Delta P}$)

ΔP (psi)	Correction factor
3	1.00
4	0.87
5	0.79
6	0.72
7	0.66
8	0.62

Correction factor for circulation rate (f_{rec})

Circulation rate	Correction factor
2	0.5
3	0.75
4	1
6	1.5
8	2
10	2.5

Nominal capacities

Wet suction line

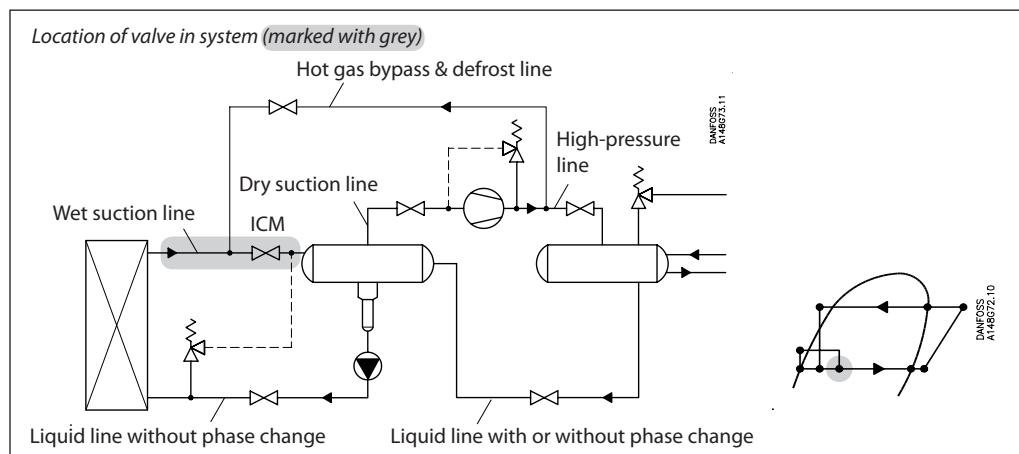

SI units

Calculation example (R717 capacities):

An application has following running conditions:

- $T_e = -20\text{ C}$
- $Q_o = 80\text{ kW}$
- Circulation rate = 3
- Max. $\Delta p = 0.3\text{ bar}$
- Connection: DN32

Therefore the actual capacity must be corrected to nominal condition by means of correction factors.

- Correction factor for $\Delta p\ 0.3\text{ bar } f_{\Delta p} = 0.82$
- Correction factor for circulation rate $f_{rec} = 0.9$

$$Q_n = Q_o \times f_{\Delta p} \times f_{rec} = 80 \times 0.82 \times 0.9 = 59\text{ kW}$$

The capacity table is based on nominal condition (pressure drop $\Delta p = 0.2\text{ bar}$, recirculation rate = 4)

From the capacity table a ICM 32-B with Q_n capacity 60.1 kW is selected.

US units

Calculation example (R717 capacities):

An application has following running conditions:

- $T_e = -20\text{ F}$
- $Q_o = 8\text{ TR}$
- Circulation rate = 3
- Max. $\Delta p = 3.5\text{ psi}$
- Connection: 1"

Therefore the actual capacity must be corrected to nominal condition by means of correction factors.

- Correction factor for $\Delta p\ 3.5\text{ psi } f_{\Delta p} = 0.91$
- Correction factor for circulation rate $f_{rec} = 0.9$

$$Q_n = Q_o \times f_{\Delta p} \times f_{rec} = 8 \times 0.91 \times 0.9 = 6.6\text{ TR}$$

The capacity table is based on nominal condition (pressure drop $\Delta p = 3\text{ psi}$, recirculation rate = 4)

From the capacity table a ICM 25-B with Q_n capacity 10.2 TR is selected.

Nominal capacities

Wet suction line

SI units

Capacity table at nominal conditions, Q_N [kW], Circulation rate = 4, $\Delta p = 0.2$ bar

R 717

Type	Valve body size	K_v (m ³ /h)	Evaporating temperature [°C]							
			-50	-40	-30	-20	-10	0	10	20
ICM20-A	20	0.6	0.9	1.3	1.7	2.1	2.5	3.0	3.4	3.9
ICM20-B		2.4	3.4	5.2	6.8	8.5	10.2	11.9	13.7	15.6
ICM20-C		4.6	6.6	10.0	13.1	16.3	19.5	22.9	26.4	29.9
ICM25-A	25	6	8.6	13.0	17.1	21.2	25.5	29.8	34.4	39.0
ICM25-B		12	17.2	26.0	34.2	42.4	50.9	59.7	68.7	78.0
ICM32-A	32	9	12.9	19.5	25.7	31.8	38.2	44.7	51.6	58.5
ICM32-B		17	24.4	36.8	48.5	60.1	72.1	84.5	97.4	111
ICM40-A	40	15	21.5	32.5	42.8	53.0	63.6	74.6	85.9	97.5
ICM40-B		26	37.3	56.3	74.1	91.9	110	129	149	169
ICM50-A	50	23	33.0	49.8	65.6	81.3	97.6	114	132	150
ICM50-B		40	57.4	86.6	114	141	170	199	229	260
ICM65-B	65	70	101	152	200	248	297	348	401	455

Correction factor for ΔP ($f_{\Delta P}$)

ΔP (bar)	Correction factor
0.05	2.00
0.1	1.41
0.2	1.00
0.3	0.82
0.4	0.71
0.5	0.63

Correction factor for circulation rate (f_{rec})

Circulation rate	Correction factor
2	0.77
3	0.90
4	1
6	1.13
8	1.20
10	1.25

US units

Capacity table at nominal conditions, Q_N [Tons of Refrigeration], Circulation rate = 4, $\Delta p = 3$ psi

R 717

Type	Valve body size	C_v (USgal/min)	Evaporating temperature [°F]							
			-60	-40	-20	0	20	40	60	80
ICM20-A	20	0.7	0.2	0.4	0.5	0.6	0.8	0.9	1.1	1.2
ICM20-B		2.8	0.9	1.5	2.0	2.6	3.1	3.7	4.3	4.9
ICM20-C		5.3	1.8	2.8	3.9	4.9	5.9	7.0	8.1	9.3
ICM25-A	25	7	2.3	3.8	5.1	6.4	7.8	9.3	10.8	12.3
ICM25-B		14	4.6	7.5	10.2	12.9	15.7	18.5	21.5	24.5
ICM32-A	32	10	3.3	5.4	7.3	9.2	11.2	13.2	15.4	17.5
ICM32-B		20	6.6	10.7	14.6	18.4	22.4	26.5	30.7	35.0
ICM40-A	40	17	5.6	9.1	12.4	15.6	19.0	22.5	26.1	29.8
ICM40-B		30	9.9	16.1	21.9	27.6	33.5	39.7	46.1	52.5
ICM50-A	50	27	8.9	14.5	19.7	24.8	30.2	35.8	41.5	47.3
ICM50-B		46	15.2	24.7	33.5	42.3	51.4	60.9	70.7	80.5
ICM65-B	65	81	26.8	43.5	59.0	74.5	90.6	107	125	142

Correction factor for ΔP ($f_{\Delta P}$)

ΔP (psi)	Correction factor
0.75	1.97
1.5	1.39
3	1.00
3.5	0.91
4	0.85
4.5	0.81

Correction factor for circulation rate (f_{rec})

Circulation rate	Correction factor
2	0.77
3	0.90
4	1
6	1.13
8	1.20
10	1.25

Nominal capacities

Wet suction line

SI units

Capacity table at nominal conditions, Q_N [kW], Circulation rate = 4, $\Delta p = 0.2$ bar

R 744

Type	Valve body size	K_v (m ³ /h)	Evaporating temperature [°C]						
			-50	-40	-30	-20	-10	0	10
ICM20-A	20	0.6	1.8	2.1	2.4	2.6	2.8	2.9	2.9
ICM20-B		2.4	7.3	8.4	9.4	10.4	11.2	11.7	11.8
ICM20-C		4.6	14.0	16.1	18.1	19.9	21.5	22.5	22.6
ICM25-A	25	6	18.3	21.0	23.6	26.0	28.0	29.3	29.5
ICM25-B		12	36.5	41.9	47.1	51.9	56.0	58.6	59.0
ICM32-A	32	9	27.4	31.4	35.4	39.0	42.0	44.0	44.2
ICM32-B		17	51.7	59.4	66.8	73.6	79.3	83.1	83.5
ICM40-A	40	15	45.6	52.4	58.9	64.9	70.0	73.3	73.7
ICM40-B		26	79.1	90.8	102	113	121	127	128
ICM50-A	50	23	70.0	80.3	90.4	100	107	112	113
ICM50-B		40	122	140	157	173	187	195	197
ICM65-B	65	70	213	245	275	303	327	342	344

Correction factor for ΔP ($f_{\Delta P}$)

ΔP (bar)	Correction factor
0.05	2.00
0.1	1.41
0.2	1.00
0.3	0.82
0.4	0.71
0.5	0.63

Correction factor for circulation rate (f_{rec})

Circulation rate	Correction factor
2	0.77
3	0.90
4	1
6	1.13
8	1.20
10	1.25

US units

Capacity table at nominal conditions, Q_N [Tons of Refrigeration], Circulation rate = 4, $\Delta p = 3$ psi

R 744

Type	Valve body size	C_v (USgal/min)	Evaporating temperature [°F]						
			-60	-40	-20	0	20	40	60
ICM20-A	20	0.7	0.5	0.6	0.7	0.8	0.8	0.9	0.8
ICM20-B		2.8	2.1	2.4	2.8	3.1	3.3	3.4	3.3
ICM20-C		5.3	4.0	4.6	5.3	5.8	6.3	6.5	6.3
ICM25-A	25	7	5.2	6.1	7.0	7.7	8.3	8.6	8.4
ICM25-B		14	10.5	12.2	13.9	15.4	16.6	17.2	16.7
ICM32-A	32	10	7.5	8.7	9.9	11.0	11.9	12.3	11.9
ICM32-B		20	14.9	17.4	19.9	22.0	23.7	24.6	23.9
ICM40-A	40	17	12.7	14.8	16.9	18.7	20.1	20.9	20.3
ICM40-B		30	22.4	26.1	29.8	33.0	35.6	36.9	35.8
ICM50-A	50	27	20.2	23.5	26.8	29.7	32.0	33.2	32.2
ICM50-B		46	34.4	40.1	45.7	50.7	54.5	56.6	54.9
ICM65-B	65	81	60.5	70.6	80.5	89.2	96.0	100	97

Correction factor for ΔP ($f_{\Delta P}$)

ΔP (psi)	Correction factor
0.75	1.97
1.5	1.39
3	1.00
3.5	0.91
4	0.85
4.5	0.81

Correction factor for circulation rate (f_{rec})

Circulation rate	Correction factor
2	0.77
3	0.90
4	1
6	1.13
8	1.20
10	1.25

Nominal capacities

Wet suction line

SI units

Capacity table at nominal conditions, Q_N [kW], Circulation rate = 4, $\Delta p = 0.2$ bar

R 134a

Type	Valve body size	K_v (m ³ /h)	Evaporating temperature [°C]						
			-40	-30	-20	-10	0	10	20
ICM20-A	20	0.6	0.4	0.5	0.7	0.8	1.0	1.1	1.2
ICM20-B		2.4	1.6	2.2	2.7	3.3	3.8	4.3	4.9
ICM20-C		4.6	3.1	4.2	5.3	6.3	7.3	8.3	9.4
ICM25-A	25	6	4.0	5.5	6.8	8.2	9.5	10.9	12.2
ICM25-B		12	8.0	11.0	13.7	16.4	19.1	21.7	24.4
ICM32-A	32	9	6.0	8.2	10.3	12.3	14.3	16.3	18.3
ICM32-B		17	11.4	15.5	19.4	23.2	27.0	30.8	34.6
ICM40-A	40	15	10.1	13.7	17.1	20.5	23.9	27.2	30.5
ICM40-B		26	17.4	23.7	29.7	35.5	41.3	47.1	52.9
ICM50-A	50	23	15.4	21.0	26.3	31.4	36.6	41.6	46.8
ICM50-B		40	26.8	36.5	45.7	54.6	63.6	72.4	81.4
ICM65-B	65	70	47.0	63.9	79.9	95.5	111	127	142

Correction factor for ΔP ($f_{\Delta P}$)

ΔP (bar)	Correction factor
0.2	1.00
0.25	0.89
0.3	0.82
0.4	0.71
0.5	0.63
0.6	0.58

Correction factor for circulation rate (f_{rec})

Circulation rate	Correction factor
2	0.77
3	0.90
4	1
6	1.13
8	1.20
10	1.25

US units

Capacity table at nominal conditions, Q_N [Tons of Refrigeration], Circulation rate = 4, $\Delta p = 3$ psi

R 134a

Type	Valve body size	C_v (USgal/min)	Evaporating temperature [°F]						
			-40	-20	0	20	40	60	80
ICM20-A	20	0.7	0.1	0.2	0.2	0.3	0.3	0.3	0.4
ICM20-B		2.8	0.5	0.7	0.8	1.0	1.2	1.4	1.5
ICM20-C		5.3	0.9	1.2	1.6	1.9	2.2	2.6	2.9
ICM25-A	25	7	1.2	1.6	2.1	2.5	2.9	3.4	3.8
ICM25-B		14	2.3	3.3	4.1	5.0	5.9	6.8	7.6
ICM32-A	32	10	1.7	2.3	3.0	3.6	4.2	4.8	5.4
ICM32-B		20	3.3	4.7	5.9	7.2	8.4	9.7	10.9
ICM40-A	40	17	2.8	4.0	5.0	6.1	7.2	8.2	9.2
ICM40-B		30	5.0	7.0	8.9	10.8	12.6	14.5	16.3
ICM50-A	50	27	4.5	6.3	8.0	9.7	11.4	13.0	14.7
ICM50-B		46	7.6	10.7	13.6	16.5	19.4	22.2	25.0
ICM65-B	65	81	13.4	18.9	24.0	29.1	34.1	39.1	44.0

Correction factor for ΔP ($f_{\Delta P}$)

ΔP (psi)	Correction factor
3	1.00
4	0.87
5	0.79
6	0.72
7	0.66
8	0.62

Correction factor for circulation rate (f_{rec})

Circulation rate	Correction factor
2	0.77
3	0.90
4	1
6	1.13
8	1.20
10	1.25

Nominal capacities

Wet suction line

SI units

Capacity table at nominal conditions, Q_N [kW], Circulation rate = 4, $\Delta p = 0.2$ bar

R 404A

Type	Valve body size	K_v (m ³ /h)	Evaporating temperature [°C]							
			-50	-40	-30	-20	-10	0	10	20
ICM20-A	20	0.6	0.5	0.7	0.8	0.9	1.0	1.2	1.3	1.4
ICM20-B		2.4	2.1	2.6	3.1	3.7	4.2	4.7	5.2	5.6
ICM20-C		4.6	4.0	5.0	6.0	7.0	8.0	9.0	10.0	10.8
ICM25-A	25	6	5.2	6.5	7.8	9.1	10.5	11.7	13.0	14.1
ICM25-B		12	10.4	13.0	15.6	18.3	20.9	23.5	26.0	28.2
ICM32-A	32	9	7.8	9.8	11.7	13.7	15.7	17.6	19.5	21.1
ICM32-B		17	14.7	18.5	22.1	25.9	29.6	33.3	36.8	39.9
ICM40-A	40	15	12.9	16.3	19.5	22.8	26.1	29.4	32.5	35.2
ICM40-B		26	22.4	28.3	33.7	39.6	45.3	50.9	56.3	61.1
ICM50-A	50	23	19.8	25.0	29.8	35.0	40.1	45.0	49.8	54.0
ICM50-B		40	34.5	43.5	51.9	60.9	69.7	78.3	86.6	93.9
ICM65-B	65	70	60.4	76.1	90.8	107	122	137	152	164

Correction factor for ΔP ($f_{\Delta P}$)

ΔP (bar)	Correction factor
0.05	2.00
0.1	1.41
0.2	1.00
0.3	0.82
0.4	0.71
0.5	0.63

Correction factor for circulation rate (f_{rec})

Circulation rate	Correction factor
2	0.77
3	0.90
4	1
6	1.13
8	1.20
10	1.25

US units

Capacity table at nominal conditions, Q_N [Tons of Refrigeration], Circulation rate = 4, $\Delta p = 3$ psi

R 404A

Type	Valve body size	C_v (USgal/min)	Evaporating temperature [°F]							
			-60	-40	-20	0	20	40	60	80
ICM20-A	20	0.7	0.1	0.2	0.2	0.3	0.3	0.4	0.4	0.4
ICM20-B		2.8	0.6	0.8	0.9	1.1	1.3	1.4	1.6	1.7
ICM20-C		5.3	1.1	1.4	1.7	2.1	2.4	2.7	3.0	3.2
ICM25-A	25	7	1.5	1.9	2.3	2.7	3.2	3.6	4.0	4.3
ICM25-B		14	2.9	3.8	4.6	5.5	6.3	7.2	7.9	8.6
ICM32-A	32	10	2.1	2.7	3.3	3.9	4.5	5.1	5.7	6.1
ICM32-B		20	4.2	5.4	6.6	7.8	9.1	10.2	11.3	12.2
ICM40-A	40	17	3.5	4.6	5.6	6.7	7.7	8.7	9.6	10.4
ICM40-B		30	6.2	8.1	9.9	11.7	13.6	15.4	17.0	18.3
ICM50-A	50	27	5.6	7.3	8.9	10.6	12.2	13.8	15.3	16.5
ICM50-B		46	9.6	12.4	15.2	18.0	20.8	23.6	26.1	28.1
ICM65-B	65	81	16.9	21.9	26.7	31.7	36.7	41.5	45.9	49.5

Correction factor for ΔP ($f_{\Delta P}$)

ΔP (psi)	Correction factor
0.75	1.97
1.5	1.39
3	1.00
3.5	0.91
4	0.85
4.5	0.81

Correction factor for circulation rate (f_{rec})

Circulation rate	Correction factor
2	0.77
3	0.90
4	1
6	1.13
8	1.20
10	1.25

Nominal capacities

Wet suction line

SI units

Capacity table at nominal conditions, Q_N [kW], Circulation rate = 4, $\Delta p = 0.2$ bar

R 22

Type	Valve body size	K_v (m ³ /h)	Evaporating temperature [°C]							
			-50	-40	-30	-20	-10	0	10	20
ICM20-A	20	0.6	0.5	0.6	0.8	0.9	1.1	1.2	1.3	1.5
ICM20-B		2.4	1.9	2.5	3.1	3.7	4.2	4.8	5.4	5.9
ICM20-C		4.6	3.7	4.8	5.9	7.0	8.1	9.2	10.3	11.4
ICM25-A	25	6	4.8	6.3	7.7	9.1	10.6	12.0	13.5	14.9
ICM25-B		12	9.6	12.6	15.4	18.3	21.2	24.1	26.9	29.7
ICM32-A	32	9	7.2	9.4	11.6	13.7	15.9	18.1	20.2	22.3
ICM32-B		17	13.6	17.8	21.9	25.9	30.0	34.1	38.1	42.1
ICM40-A	40	15	12.0	15.7	19.3	22.8	26.5	30.1	33.6	37.2
ICM40-B		26	20.7	27.2	33.4	39.6	45.9	52.2	58.3	64.4
ICM50-A	50	23	18.3	24.1	29.6	35.0	40.6	46.2	51.6	57.0
ICM50-B		40	31.9	41.9	51.4	60.9	70.6	80.3	89.7	99.1
ICM65-B	65	70	55.8	73.3	90.0	107	124	141	157	173

Correction factor for ΔP ($f_{\Delta P}$)

ΔP (bar)	Correction factor
0.2	1.00
0.25	0.89
0.3	0.82
0.4	0.71
0.5	0.63
0.6	0.58

Correction factor for circulation rate (f_{rec})

Circulation rate	Correction factor
2	0.77
3	0.90
4	1
6	1.13
8	1.20
10	1.25

US units

Capacity table at nominal conditions, Q_N [Tons of Refrigeration], Circulation rate = 4, $\Delta p = 3$ psi

R 22

Type	Valve body size	C_v (USgal/min)	Evaporating temperature [°F]							
			-60	-40	-20	0	20	40	60	80
ICM20-A	20	0.7	0.1	0.2	0.2	0.3	0.3	0.4	0.4	0.5
ICM20-B		2.8	0.5	0.7	0.9	1.1	1.3	1.5	1.7	1.8
ICM20-C		5.3	1.0	1.4	1.7	2.1	2.4	2.8	3.1	3.5
ICM25-A	25	7	1.3	1.8	2.3	2.8	3.2	3.7	4.1	4.6
ICM25-B		14	2.7	3.6	4.6	5.5	6.4	7.4	8.3	9.2
ICM32-A	32	10	1.9	2.6	3.3	3.9	4.6	5.3	5.9	6.5
ICM32-B		20	3.8	5.2	6.5	7.9	9.2	10.5	11.9	13.1
ICM40-A	40	17	3.2	4.4	5.6	6.7	7.8	9.0	10.1	11.1
ICM40-B		30	5.7	7.8	9.8	11.8	13.8	15.8	17.8	19.6
ICM50-A	50	27	5.1	7.0	8.8	10.6	12.4	14.2	16.0	17.7
ICM50-B		46	8.7	12.0	15.0	18.1	21.2	24.2	27.3	30.1
ICM65-B	65	81	15.4	21.1	26.5	31.9	37.3	42.7	48.0	53.0

Correction factor for ΔP ($f_{\Delta P}$)

ΔP (psi)	Correction factor
3	1.00
4	0.87
5	0.79
6	0.72
7	0.66
8	0.62

Correction factor for circulation rate (f_{rec})

Circulation rate	Correction factor
2	0.77
3	0.90
4	1
6	1.13
8	1.20
10	1.25

Nominal capacities

Dry suction line

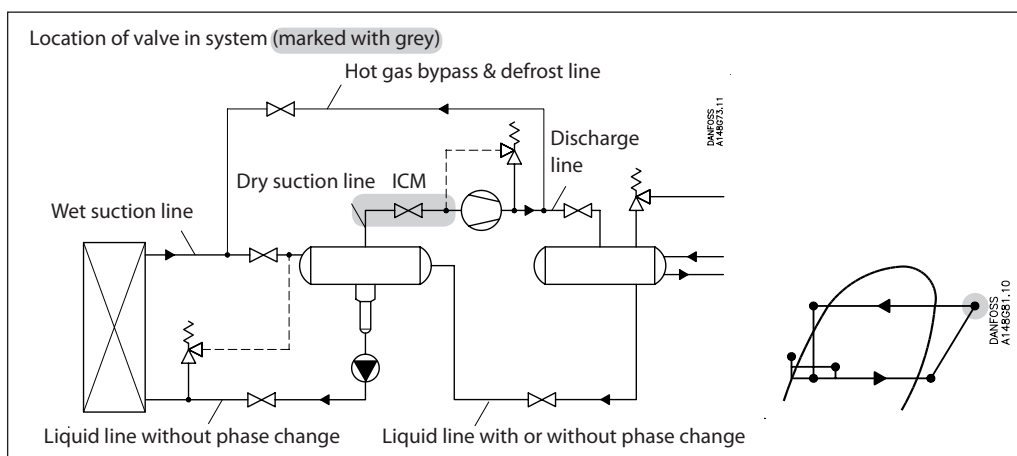

SI units

Calculation example (R717 capacities):

An application has following running conditions:

- $T_e = -20^\circ\text{C}$
- $Q_o = 90 \text{ kW}$
- $T_{liq} = 10^\circ\text{C}$
- Max. $\Delta p = 0.3 \text{ bar}$
- Connection: DN32

Therefore the actual capacity must be corrected to nominal condition by means of correction factors.
 Correction factor for Δp 0.3 bar $f_{\Delta p} = 0.82$
 Correction factor for liquid temperature $f_{T_{liq}} = 0.92$

$$Q_n = Q_o \times f_{\Delta p} \times f_{T_{liq}} = 90 \times 0.82 \times 0.92 = 68 \text{ kW}$$

The capacity table is based on nominal condition ($\Delta p = 0.2 \text{ bar}$, $T_{liq} = 30^\circ\text{C}$)

From the capacity table a ICM 32-B with Q_n capacity 92.3 kW is selected.

US units

Calculation example (R717 capacities):

An application has following running conditions:

- $T_e = 0^\circ\text{F}$
- $Q_o = 20 \text{ TR}$
- $T_{liq} = 50^\circ\text{F}$
- Max. $\Delta p = 3.5 \text{ psi}$
- Connection: $1\frac{1}{4}''$

Therefore the actual capacity must be corrected to nominal condition by means of correction factors.
 Correction factor for Δp 3.5 psi $f_{\Delta p} = 0.91$
 Correction factor for liquid temperature $f_{T_{liq}} = 0.92$

$$Q_n = Q_o \times f_{\Delta p} \times f_{T_{liq}} = 20 \times 0.91 \times 0.92 = 16.7 \text{ TR}$$

The capacity table is based on nominal condition ($\Delta p = 3 \text{ psi}$, $T_{liq} = 90^\circ\text{F}$)

From the capacity table a ICM 32-B with Q_n capacity 28.2 TR is selected.

Nominal capacities

Dry suction line

SI units

Capacity table at nominal conditions, Q_N [kW],
 $T_{liq} = 30^\circ\text{C}$,
 $\Delta p = 0.2 \text{ bar}$
 Superheating = 8°C

R 717

Type	Valve body size	K_v (m ³ /h)	Evaporating temperature [°C]							
			-50	-40	-30	-20	-10	0	10	20
ICM20-A	20	0.6	1.6	2.0	2.6	3.3	4.0	4.9	5.9	6.9
ICM20-B		2.4	6.2	8.0	10.3	13.0	16.1	19.5	23.4	27.7
ICM20-C		4.6	11.9	15.3	19.8	25.0	30.9	37.5	44.9	53.0
ICM25-A	25	6	15.5	20.0	25.8	32.6	40.3	48.9	58.5	69.2
ICM25-B		12	31.0	40.0	51.6	65.1	80.6	97.7	117	138
ICM32-A	32	9	23.3	30.0	38.7	48.9	60.4	73.3	87.8	104
ICM32-B		17	44.0	56.7	73.1	92.3	114	138	166	196
ICM40-A	40	15	38.8	50.0	64.5	81.4	101	122	146	173
ICM40-B		26	67.2	86.7	112	141	175	212	254	300
ICM50-A	50	23	59.5	76.7	98.9	125	154	187	224	265
ICM50-B		40	103	133	172	217	269	326	390	461
ICM65-B	65	70	181	234	301	380	470	570	683	807

Correction factor for ΔP ($f_{\Delta P}$)

ΔP (bar)	Correction factor
0.05	2.00
0.1	1.41
0.2	1.00
0.3	0.82
0.4	0.71
0.5	0.63

Correction factor for liquid temperature (T_{liq})

Liquid temperature	Correction factor
-20°C	0.82
-10°C	0.86
0°C	0.88
10°C	0.92
20°C	0.96
30°C	1.00
40°C	1.04
50°C	1.09

US units

Capacity table at nominal conditions, Q_N [Tons of Refrigeration],
 $T_{liq} = 90^\circ\text{F}$,
 $\Delta p = 3 \text{ psi}$
 Superheating = 12°F

R 717

Type	Valve body size	C_v (USgal/min)	Evaporating temperature [°F]							
			-60	-40	-20	0	20	40	60	80
ICM20-A	20	0.7	0.5	0.6	0.8	1.0	1.2	1.5	1.9	2.2
ICM20-B		2.8	1.9	2.3	3.1	3.9	5.0	6.1	7.4	8.8
ICM20-C		5.3	3.5	4.4	5.8	7.5	9.4	11.6	14.0	16.8
ICM25-A	25	7	4.7	5.8	7.6	9.9	12.4	15.3	18.5	22.1
ICM25-B		14	9.3	11.6	15.3	19.7	24.8	30.6	37.1	44.2
ICM32-A	32	10	6.7	8.3	10.9	14.1	17.7	21.9	26.5	31.6
ICM32-B		20	13.3	16.5	21.9	28.2	35.5	43.8	53.0	63.2
ICM40-A	40	17	11.3	14.0	18.6	23.9	30.1	37.2	45.0	53.7
ICM40-B		30	20.0	24.8	32.8	42.3	53.2	65.6	79.4	94.8
ICM50-A	50	27	18.0	22.3	29.5	38.0	47.9	59.1	71.5	85.3
ICM50-B		46	30.7	38.0	50.3	64.8	81.6	101	122	145
ICM65-B	65	81	54.0	66.9	88.5	114	144	177	215	256

Correction factor for ΔP ($f_{\Delta P}$)

ΔP (psi)	Correction factor
0.75	1.97
1.5	1.39
3	1.00
3.5	0.91
4	0.85
4.5	0.81

Correction factor for superheat (T_s)

T_s	Correction factor
10°F	1.00
14°F	1.00
18°F	1.00
20°F	1.00

Correction factor for liquid temperature (T_{liq})

Liquid temperature	Correction factor
-10°F	0.82
10°F	0.85
30°F	0.88
50°F	0.92
70°F	0.96
90°F	1.00
110°F	1.04
130°F	1.09

Nominal capacities

Dry suction line

SI units

Capacity table at nominal conditions, Q_N [kW],
 $T_{liq} = 10^\circ\text{C}$,
 $\Delta p = 0.2$ bar
 Superheating = 8°C

R 744

Type	Valve body size	K_v (m ³ /h)	Evaporating temperature [°C]						
			-50	-40	-30	-20	-10	0	10
ICM20-A	20	0.6	2.1	2.6	3.1	3.7	4.3	4.9	5.6
ICM20-B		2.4	8.4	10.3	12.4	14.6	17.1	19.6	22.3
ICM20-C		4.6	16.1	19.7	23.7	28.1	32.7	37.7	42.8
ICM25-A	25	6	21.0	25.8	30.9	36.6	42.7	49.1	55.8
ICM25-B		12	42.1	51.5	61.9	73.2	85.4	98.2	112
ICM32-A	32	9	31.6	38.6	46.4	54.9	64.0	73.7	83.7
ICM32-B		17	59.6	73.0	87.7	104	121	139	158
ICM40-A	40	15	52.6	64.4	77.4	91.5	107	123	140
ICM40-B		26	91.2	112	134	159	185	213	242
ICM50-A	50	23	80.7	98.7	119	140	164	188	214
ICM50-B		40	140	172	206	244	285	327	372
ICM65-B	65	70	246	301	361	427	498	573	651

Correction factor for ΔP ($f_{\Delta P}$)

ΔP (bar)	Correction factor
0.05	2.00
0.1	1.41
0.2	1.00
0.3	0.82
0.4	0.71
0.5	0.63

Correction factor for liquid temperature (T_{liq})

Liquid temperature	Correction factor
-20°C	0.52
-10°C	0.67
0°C	0.91
10°C	1.00
15°C	1.09

US units

Capacity table at nominal conditions, Q_N [Tons of Refrigeration],
 $T_{liq} = 50^\circ\text{F}$,
 $\Delta p = 3$ psi
 Superheating = 12°F

R 744

Type	Valve body size	C_v (USgal/min)	Evaporating temperature [°F]						
			-60	-40	-20	0	20	40	60
ICM20-A	20	0.7	0.6	0.7	0.9	1.1	1.3	1.5	1.7
ICM20-B		2.8	2.4	3.0	3.7	4.4	5.2	6.0	6.9
ICM20-C		5.3	4.5	5.7	6.9	8.3	9.8	11.4	13.0
ICM25-A	25	7	6.0	7.5	9.1	11.0	13.0	15.1	17.2
ICM25-B		14	11.9	14.9	18.3	22.0	26.0	30.2	34.5
ICM32-A	32	10	8.5	10.7	13.1	15.7	18.5	21.5	24.6
ICM32-B		20	17.0	21.3	26.1	31.4	37.1	43.1	49.2
ICM40-A	40	17	14.5	18.1	22.2	26.7	31.5	36.6	41.8
ICM40-B		30	25.5	32.0	39.2	47.1	55.6	64.6	73.9
ICM50-A	50	27	23.0	28.8	35.3	42.4	50.1	58.2	66.5
ICM50-B		46	39.1	49.1	60.1	72.2	85.3	99.1	113
ICM65-B	65	81	68.9	86.4	106	127	150	175	199

Correction factor for ΔP ($f_{\Delta P}$)

ΔP (psi)	Correction factor
0.75	1.97
1.5	1.39
3	1.00
3.5	0.91
4	0.85
4.5	0.81

Correction factor for superheat (T_s)

T_s	Correction factor
10°F	1.00
14°F	1.00
18°F	1.00
20°F	1.00

Correction factor for liquid temperature (T_{liq})

Liquid temperature	Correction factor
-10°F	0.48
10°F	0.64
30°F	0.88
50°F	1.00

Nominal capacities

Dry suction line

SI units

Capacity table at nominal conditions, Q_N [kW],
 $T_{liq} = 30^\circ\text{C}$,
 $\Delta p = 0.2 \text{ bar}$
 Superheating = 8°C

R 134a

Type	Valve body size	K_v (m^3/h)	Evaporating temperature [$^\circ\text{C}$]						
			-40	-30	-20	-10	0	10	20
ICM20-A	20	0.6	0.5	0.7	0.9	1.2	1.4	1.8	2.1
ICM20-B		2.4	2.1	2.8	3.6	4.6	5.7	7.0	8.5
ICM20-C		4.6	4.1	5.4	7.0	8.8	11.0	13.5	16.3
ICM25-A	25	6	5.3	7.0	9.1	11.5	14.4	17.6	21.3
ICM25-B		12	10.6	14.1	18.2	23.1	28.7	35.2	42.6
ICM32-A	32	9	8.0	10.5	13.6	17.3	21.5	26.4	32.0
ICM32-B		17	15.1	19.9	25.7	32.7	40.7	49.9	60.4
ICM40-A	40	15	13.3	17.6	22.7	28.8	35.9	44.0	53.3
ICM40-B		26	23.1	30.5	39.4	50.0	62.2	76.3	92.3
ICM50-A	50	23	20.4	26.9	34.8	44.2	55.0	67.5	81.7
ICM50-B		40	35.5	46.9	60.6	76.9	95.7	117	142
ICM65-B	65	70	62.1	82.0	106	135	168	206	249

Correction factor for ΔP ($f_{\Delta P}$)

ΔP (bar)	Correction factor
0.05	2.00
0.1	1.41
0.2	1.00
0.3	0.82
0.4	0.71
0.5	0.63

Correction factor for liquid temperature (T_{liq})

Liquid temperature	Correction factor
-20 $^\circ\text{C}$	0.66
-10 $^\circ\text{C}$	0.70
0 $^\circ\text{C}$	0.76
10 $^\circ\text{C}$	0.82
20 $^\circ\text{C}$	0.90
30$^\circ\text{C}$	1.00
40 $^\circ\text{C}$	1.13
50 $^\circ\text{C}$	1.29

US units

Capacity table at nominal conditions, Q_N [Tons of Refrigeration],
 $T_{liq} = 90^\circ\text{F}$,
 $\Delta p = 3 \text{ psi}$
 Superheating = 12°F

R 134a

Type	Valve body size	C_v (USgal/min)	Evaporating temperature [$^\circ\text{F}$]						
			-40	-20	0	20	40	60	80
ICM20-A	20	0.7	0.2	0.2	0.3	0.4	0.4	0.6	0.7
ICM20-B		2.8	0.6	0.8	1.1	1.4	1.8	2.2	2.7
ICM20-C		5.3	1.1	1.6	2.1	2.7	3.4	4.2	5.2
ICM25-A	25	7	1.5	2.1	2.7	3.5	4.5	5.6	6.9
ICM25-B		14	3.0	4.1	5.4	7.1	9.0	11.2	13.7
ICM32-A	32	10	2.2	2.9	3.9	5.0	6.4	8.0	9.8
ICM32-B		20	4.3	5.9	7.8	10.1	12.8	16.0	19.6
ICM40-A	40	17	3.7	5.0	6.6	8.6	10.9	13.6	16.6
ICM40-B		30	6.5	8.8	11.7	15.1	19.2	23.9	29.4
ICM50-A	50	27	5.8	7.9	10.5	13.6	17.3	21.5	26.4
ICM50-B		46	9.9	13.5	17.9	23.2	29.4	36.7	45.0
ICM65-B	65	81	17.4	23.8	31.5	40.8	51.8	64.6	79.3

Correction factor for ΔP ($f_{\Delta P}$)

ΔP (psi)	Correction factor
0.75	1.97
1.5	1.39
3	1.00
3.5	0.91
4	0.85
4.5	0.81

Correction factor for superheat (T_s)

T_s	Correction factor
10 $^\circ\text{F}$	1.00
14 $^\circ\text{F}$	1.00
18 $^\circ\text{F}$	1.00
20 $^\circ\text{F}$	1.00

Correction factor for liquid temperature (T_{liq})

Liquid temperature	Correction factor
-10 $^\circ\text{F}$	0.64
10 $^\circ\text{F}$	0.68
30 $^\circ\text{F}$	0.74
50 $^\circ\text{F}$	0.81
70 $^\circ\text{F}$	0.89
90$^\circ\text{F}$	1.00
110 $^\circ\text{F}$	1.15
130 $^\circ\text{F}$	1.35

Nominal capacities

Dry suction line

SI units

Capacity table at nominal conditions, Q_N [kW],
 $T_{liq} = 30^\circ\text{C}$,
 $\Delta p = 0.2$ bar
 Superheating = 8°C

R 404A

Type	Valve body size	K_v (m ³ /h)	Evaporating temperature [°C]							
			-50	-40	-30	-20	-10	0	10	20
ICM20-A	20	0.6	0.5	0.6	0.8	1.1	1.3	1.6	2.0	2.4
ICM20-B		2.4	1.9	2.5	3.3	4.2	5.3	6.5	8.0	9.6
ICM20-C		4.6	3.6	4.9	6.3	8.1	10.2	12.5	15.2	18.3
ICM25-A	25	6	4.8	6.4	8.3	10.6	13.2	16.3	19.9	23.9
ICM25-B		12	9.5	12.7	16.5	21.1	26.5	32.7	39.8	47.8
ICM32-A	32	9	7.1	9.5	12.4	15.9	19.9	24.5	29.8	35.9
ICM32-B		17	13.5	18.0	23.4	29.9	37.5	46.3	56.3	67.8
ICM40-A	40	15	11.9	15.9	20.7	26.4	33.1	40.8	49.7	59.8
ICM40-B		26	20.6	27.5	35.8	45.8	57.4	70.8	86.2	104
ICM50-A	50	23	18.2	24.3	31.7	40.5	50.8	62.6	76.2	91.7
ICM50-B		40	31.7	42.3	55.1	70.5	88.3	109	133	159
ICM65-B	65	70	55.5	74.1	96.5	123	155	191	232	279

Correction factor for liquid temperature (T_{liq})

Liquid temperature	Correction factor
-20°C	0.55
-10°C	0.60
0°C	0.66
10°C	0.74
20°C	0.85
30°C	1.00
40°C	1.23
50°C	1.68

Correction factor for ΔP ($f_{\Delta P}$)

ΔP (bar)	Correction factor
0.05	2.00
0.1	1.41
0.2	1.00
0.3	0.82
0.4	0.71
0.5	0.63

US units

Capacity table at nominal conditions, Q_N [Tons of Refrigeration],
 $T_{liq} = 90^\circ\text{F}$,
 $\Delta p = 3$ psi
 Superheating = 12°F

R 404A

Type	Valve body size	C_v (USgal/min)	Evaporating temperature [°F]							
			-60	-40	-20	0	20	40	60	80
ICM20-A	20	0.7	0.1	0.2	0.2	0.3	0.4	0.5	0.6	0.8
ICM20-B		2.8	0.5	0.7	1.0	1.2	1.6	2.0	2.5	3.0
ICM20-C		5.3	1.0	1.3	1.8	2.4	3.0	3.8	4.7	5.7
ICM25-A	25	7	1.3	1.8	2.4	3.1	4.0	5.0	6.2	7.6
ICM25-B		14	2.6	3.5	4.8	6.2	8.0	10.0	12.4	15.2
ICM32-A	32	10	1.8	2.5	3.4	4.5	5.7	7.2	8.9	10.8
ICM32-B		20	3.7	5.1	6.8	8.9	11.4	14.3	17.8	21.7
ICM40-A	40	17	3.1	4.3	5.8	7.6	9.7	12.2	15.1	18.4
ICM40-B		30	5.5	7.6	10.2	13.4	17.1	21.5	26.6	32.5
ICM50-A	50	27	4.9	6.8	9.2	12.0	15.4	19.4	24.0	29.3
ICM50-B		46	8.4	11.6	15.7	20.5	26.2	33.0	40.8	49.9
ICM65-B	65	81	14.8	20.5	27.6	36.1	46.2	58.1	71.9	87.8

Correction factor for liquid temperature (T_{liq})

Liquid temperature	Correction factor
-10°F	0.52
10°F	0.57
30°F	0.63
50°F	0.72
70°F	0.83
90°F	1.00
110°F	1.29
130°F	1.92

Correction factor for ΔP ($f_{\Delta P}$)

ΔP (psi)	Correction factor
0.75	1.97
1.5	1.39
3	1.00
3.5	0.91
4	0.85
4.5	0.81

Correction factor for superheat (T_s)

T_s	Correction factor
10°F	1.00
14°F	1.00
18°F	1.00
20°F	1.00

Nominal capacities

Dry suction line

SI units

Capacity table at nominal conditions, Q_N [kW],
 $T_{liq} = 30^\circ\text{C}$,
 $\Delta p = 0.2 \text{ bar}$
 Superheating = 8°C

R 22

Type	Valve body size	K_v (m ³ /h)	Evaporating temperature [°C]							
			-50	-40	-30	-20	-10	0	10	20
ICM20-A	20	0.6	0.6	0.8	1.0	1.3	1.5	1.9	2.2	2.6
ICM20-B		2.4	2.5	3.2	4.1	5.0	6.2	7.4	8.8	10.4
ICM20-C		4.6	4.7	6.1	7.8	9.7	11.8	14.2	16.9	19.9
ICM25-A	25	6	6.2	8.0	10.1	12.6	15.4	18.6	22.1	26.0
ICM25-B		12	12.3	16.0	20.3	25.2	30.8	37.1	44.1	51.9
ICM32-A	32	9	9.3	12.0	15.2	18.9	23.1	27.8	33.1	39.0
ICM32-B		17	17.5	22.6	28.7	35.7	43.6	52.6	62.5	73.6
ICM40-A	40	15	15.4	20.0	25.4	31.5	38.5	46.4	55.2	64.9
ICM40-B		26	26.7	34.6	43.9	54.6	66.7	80.4	95.6	113
ICM50-A	50	23	23.7	30.6	38.9	48.3	59.0	71.1	84.6	100
ICM50-B		40	41.1	53.3	67.6	84.0	103	124	147	173
ICM65-B	65	70	72.0	93.2	118	147	180	217	258	303

Correction factor for ΔP ($f_{\Delta P}$)

ΔP (bar)	Correction factor
0.2	1.00
0.25	0.89
0.3	0.82
0.4	0.71
0.5	0.63
0.6	0.58

Correction factor for liquid temperature (T_{liq})

Liquid temperature	Correction factor
-20°C	0.71
-10°C	0.75
0°C	0.80
10°C	0.86
20°C	0.92
30°C	1.00
40°C	1.09
50°C	1.22

US units

Capacity table at nominal conditions, Q_N [Tons of Refrigeration],
 $T_{liq} = 90^\circ\text{F}$,
 $\Delta p = 3 \text{ psi}$
 Superheating = 12°F

R 22

Type	Valve body size	C_v (USgal/min)	Evaporating temperature [°F]							
			-60	-40	-20	0	20	40	60	80
ICM20-A	20	0.7	0.2	0.2	0.3	0.4	0.5	0.6	0.7	0.8
ICM20-B		2.8	0.7	0.9	1.2	1.5	1.9	2.3	2.8	3.3
ICM20-C		5.3	1.3	1.7	2.2	2.9	3.6	4.3	5.2	6.2
ICM25-A	25	7	1.7	2.3	3.0	3.8	4.7	5.7	6.9	8.2
ICM25-B		14	3.4	4.6	5.9	7.5	9.4	11.5	13.8	16.4
ICM32-A	32	10	2.4	3.3	4.2	5.4	6.7	8.2	9.9	11.7
ICM32-B		20	4.9	6.5	8.5	10.8	13.4	16.4	19.8	23.5
ICM40-A	40	17	4.1	5.5	7.2	9.2	11.4	13.9	16.8	20.0
ICM40-B		30	7.3	9.8	12.7	16.1	20.1	24.6	29.6	35.2
ICM50-A	50	27	6.6	8.8	11.4	14.5	18.1	22.1	26.7	31.7
ICM50-B		46	11.2	15.0	19.5	24.8	30.8	37.7	45.4	54.0
ICM65-B	65	81	19.7	26.4	34.3	43.6	54.3	66.4	80.0	95.1

Correction factor for ΔP ($f_{\Delta P}$)

ΔP (psi)	Correction factor
3	1.00
4	0.87
5	0.79
6	0.72
7	0.66
8	0.62

Correction factor for superheat (T_s)

T_s	Correction factor
10°F	1.00
14°F	1.00
18°F	1.00
20°F	1.00

Correction factor for liquid temperature (T_{liq})

Liquid temperature	Correction factor
-10°F	0.73
10°F	0.77
30°F	0.82
50°F	0.87
70°F	0.93
90°F	1.00
110°F	1.09
130°F	1.20

Nominal capacities

Discharge line

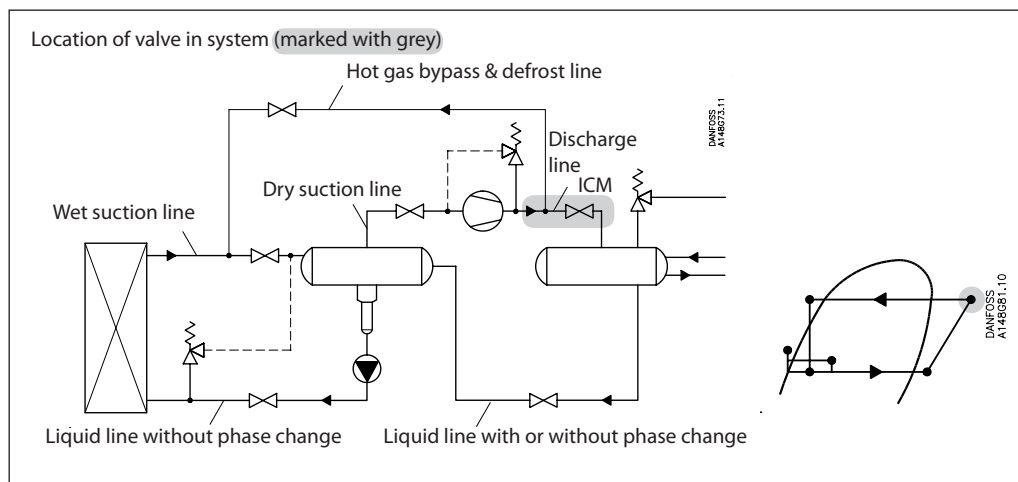

SI units

Calculation example (R717 capacities):

An application has following running conditions:

$T_e = -20^\circ\text{C}$
 $Q_o = 90 \text{ kW}$
 $T_{liq} = 10^\circ\text{C}$
 Max. $\Delta p = 0.4 \text{ bar}$
 $T_{disch.} = 60^\circ\text{C}$
 Connection: DN25

The capacity table is based on nominal condition
 ($\Delta p = 0.2 \text{ bar}$, $T_{liq} = 30^\circ\text{C}$, $P_{disch.} = 12 \text{ bar}$, $T_{disch.} = 80^\circ\text{C}$)

Therefore the actual capacity must be corrected to nominal condition by means of correction factors.

Correction factor for Δp 0.4 bar $f_{\Delta p} = 0.72$
 Correction factor for liquid temperature $f_{T_{liq}} = 0.92$
 Correction factor for $T_{disch.}$ 60°C , $f_{disch.} = 0.97$

$$Q_n = Q_o \times f_{\Delta p} \times f_{T_{liq}} \times f_{T_{disch.}} = 90 \times 0.72 \times 0.92 \times 0.97 = 58 \text{ kW}$$

From the capacity table a ICM 25-A with Q_n capacity 73.2 kW is selected.

US units

Calculation example (R717 capacities):

An application has following running conditions:

$T_e = 0^\circ\text{F}$
 $Q_o = 8 \text{ TR}$
 $T_{liq} = 50^\circ\text{F}$
 Max. $\Delta p = 4.5 \text{ psi}$
 $T_{disch.} = 120^\circ\text{F}$
 Connection: $3/4''$

The capacity table is based on nominal condition
 ($\Delta p = 3 \text{ psi}$, $T_{liq} = 90^\circ\text{F}$, $P_{disch.} = 185 \text{ psi}$, $T_{disch.} = 180^\circ\text{F}$)

Therefore the actual capacity must be corrected to nominal condition by means of correction factors.

Correction factor for Δp 4.5 psi $f_{\Delta p} = 0.81$
 Correction factor for liquid temperature $f_{T_{liq}} = 0.92$
 Correction factor for $T_{disch.}$ 120°F , $f_{disch.} = 0.95$

$$Q_n = Q_o \times f_{\Delta p} \times f_{T_{liq}} \times f_{T_{disch.}} = 8 \times 0.81 \times 0.92 \times 0.95 = 5.7 \text{ TR}$$

From the capacity table a ICM 20-B with Q_n capacity 8.4 TR is selected.

Nominal capacities

Discharge line

SI units

Capacity table at nominal conditions, Q_N [kW],
 $T_{liq} = 30^\circ\text{C}$,
 $\Delta p = 0.2 \text{ bar}$,
 $P_{disch.} = 12 \text{ bar}$,
 $T_{disch.} = 80^\circ\text{C}$
 Superheating = 8°C

R 717

Type	Valve body size	K_v (m^3/h)	Evaporating temperature [$^\circ\text{C}$]							
			-50	-40	-30	-20	-10	0	10	20
ICM20-A	20	0.6	7.0	7.1	7.2	7.3	7.4	7.5	7.5	7.6
ICM20-B		2.4	28.0	28.5	28.9	29.3	29.6	29.9	30.1	30.3
ICM20-C		4.6	53.7	54.5	55.4	56.1	56.8	57.3	57.8	58.1
ICM25-A	25	6	70.0	71.1	72.3	73.2	74.1	74.7	75.3	75.8
ICM25-B		12	140	142	145	146	148	149	151	152
ICM32-A	32	9	105	107	108	110	111	112	113	114
ICM32-B		17	198	202	205	207	210	212	213	215
ICM40-A	40	15	175	178	181	183	185	187	188	189
ICM40-B		26	303	308	313	317	321	324	326	328
ICM50-A	50	23	268	273	277	281	284	287	289	290
ICM50-B		40	467	474	482	488	494	498	502	505
ICM65-B	65	70	817	830	843	854	864	872	879	884

Correction factor for ΔP ($f_{\Delta P}$)

ΔP (bar)	Correction factor
0.05	2.00
0.1	1.41
0.2	1.00
0.3	0.82
0.4	0.71
0.5	0.63

Correction factor for discharge temperature ($T_{disch.}$)

Discharge temperature	Correction factor
50 $^\circ\text{C}$	0.96
60 $^\circ\text{C}$	0.97
80$^\circ\text{C}$	1.00
90 $^\circ\text{C}$	1.01
100 $^\circ\text{C}$	1.03
110 $^\circ\text{C}$	1.04
120 $^\circ\text{C}$	1.06

Correction factor for liquid temperature (T_{liq})

Liquid temperature	Correction factor
-20 $^\circ\text{C}$	0.82
-10 $^\circ\text{C}$	0.86
0 $^\circ\text{C}$	0.88
10 $^\circ\text{C}$	0.92
20 $^\circ\text{C}$	0.96
30$^\circ\text{C}$	1.00
40 $^\circ\text{C}$	1.04
50 $^\circ\text{C}$	1.09

US units

Capacity table at nominal conditions, Q_N [Tons of Refrigeration],
 $T_{liq} = 90^\circ\text{F}$,
 $\Delta p = 2.9 \text{ psi}$,
 $P_{disch.} = 185 \text{ psi}$,
 $T_{disch.} = 180^\circ\text{F}$
 Superheating = 12°F

R 717

Type	Valve body size	C_v (USgal/min)	Evaporating temperature [$^\circ\text{F}$]							
			-60	-40	-20	0	20	40	60	80
ICM20-A	20	0.7	2.0	2.0	2.1	2.1	2.1	2.2	2.2	2.2
ICM20-B		2.8	8.0	8.2	8.3	8.4	8.5	8.6	8.7	8.7
ICM20-C		5.3	15.2	15.4	15.7	15.9	16.1	16.3	16.4	16.5
ICM25-A	25	7	20.0	20.4	20.7	21.0	21.3	21.5	21.7	21.8
ICM25-B		14	40.1	40.8	41.5	42.0	42.6	43.0	43.4	43.6
ICM32-A	32	10	28.6	29.1	29.6	30.0	30.4	30.7	31.0	31.2
ICM32-B		20	57.3	58.3	59.3	60.0	60.9	61.5	62.0	62.3
ICM40-A	40	17	48.7	49.5	50.4	51.0	51.7	52.3	52.7	53.0
ICM40-B		30	85.9	87.4	88.9	90.0	91.3	92.2	93.0	93.5
ICM50-A	50	27	77.3	78.7	80.0	81.0	82.2	83.0	83.7	84.2
ICM50-B		46	132	134	136	138	140	141	143	143
ICM65-B	65	81	232	236	240	243	247	249	251	253

Correction factor for ΔP ($f_{\Delta P}$)

ΔP (psi)	Correction factor
0.75	1.97
1.5	1.39
3	1.00
3.5	0.91
4	0.85
4.5	0.81

Correction factor for discharge temperature ($T_{disch.}$)

Discharge temperature	Correction factor
120 $^\circ\text{F}$	0.95
140 $^\circ\text{F}$	0.97
180$^\circ\text{F}$	1.00
200 $^\circ\text{F}$	1.02
210 $^\circ\text{F}$	1.02
230 $^\circ\text{F}$	1.04
250 $^\circ\text{F}$	1.05

Correction factor for liquid temperature (T_{liq})

Liquid temperature	Correction factor
-10 $^\circ\text{F}$	0.82
10 $^\circ\text{F}$	0.85
30 $^\circ\text{F}$	0.88
50 $^\circ\text{F}$	0.92
70 $^\circ\text{F}$	0.96
90$^\circ\text{F}$	1.00
110 $^\circ\text{F}$	1.04
130 $^\circ\text{F}$	1.09

Nominal capacities

Discharge line

SI units

Capacity table at nominal conditions, Q_N [kW],
 $T_{liq} = 10^\circ\text{C}$,
 $\Delta p = 0.2 \text{ bar}$,
 $P_{disch.} = 10 \text{ bar}$,
 $T_{disch.} = 80^\circ\text{C}$
 Superheating = 8°C

R 744

Type	Valve body size	K_v (m^3/h)	Evaporating temperature [$^\circ\text{C}$]						
			-50	-40	-30	-20	-10	0	10
ICM20-A	20	0.6	4.4	4.5	4.5	4.6	4.6	4.5	4.4
ICM20-B		2.4	17.7	17.9	18.1	18.2	18.2	18.0	17.7
ICM20-C		4.6	33.8	34.4	34.8	34.9	34.9	34.6	33.9
ICM25-A	25	6	44.1	44.8	45.3	45.5	45.5	45.1	44.2
ICM25-B		12	88.3	89.7	90.7	91.0	91.0	90.2	88.5
ICM32-A	32	9	66.2	67.2	68.0	68.3	68.3	67.6	66.3
ICM32-B		17	125	127	128	129	129	128	125
ICM40-A	40	15	110	112	113	114	114	113	111
ICM40-B		26	191	194	196	197	197	195	192
ICM50-A	50	23	169	172	174	174	174	173	170
ICM50-B		40	294	299	302	303	303	301	295
ICM65-B	65	70	515	523	529	531	531	526	516

Correction factor for discharge temperature ($T_{disch.}$).

Discharge temperature	Correction factor
50 $^\circ\text{C}$	0.96
60 $^\circ\text{C}$	0.97
80$^\circ\text{C}$	1.00
90 $^\circ\text{C}$	1.01
100 $^\circ\text{C}$	1.03
110 $^\circ\text{C}$	1.04
120 $^\circ\text{C}$	1.06

Correction factor for ΔP ($f_{\Delta P}$)

ΔP (bar)	Correction factor
0.05	2.00
0.1	1.41
0.2	1.00
0.3	0.82
0.4	0.71
0.5	0.63

Correction factor for liquid temperature (T_{liq})

Liquid temperature	Correction factor
-20 $^\circ\text{C}$	0.52
-10 $^\circ\text{C}$	0.67
0 $^\circ\text{C}$	0.91
10$^\circ\text{C}$	1.00
15 $^\circ\text{C}$	1.09

US units

Capacity table at nominal conditions, Q_N [Tons of Refrigeration],
 $T_{liq} = 90^\circ\text{F}$,
 $\Delta p = 3 \text{ psi}$,
 $P_{disch.} = 120 \text{ psi}$,
 $T_{disch.} = 180^\circ\text{F}$
 Superheating = 12°F

R 744

Type	Valve body size	C_v (USgal/min)	Evaporating temperature [$^\circ\text{F}$]						
			-60	-40	-20	0	20	40	60
ICM20-A	20	0.7	1.2	1.3	1.3	1.3	1.3	1.2	1.2
ICM20-B		2.8	4.9	5.0	5.1	5.1	5.1	5.0	5.0
ICM20-C		5.3	9.3	9.5	9.6	9.7	9.6	9.5	9.5
ICM25-A	25	7	12.3	12.6	12.7	12.8	12.7	12.5	12.5
ICM25-B		14	24.7	25.1	25.4	25.5	25.4	25.0	25.0
ICM32-A	32	10	17.6	18.0	18.1	18.2	18.1	17.8	17.8
ICM32-B		20	35.3	35.9	36.3	36.5	36.3	35.7	35.7
ICM40-A	40	17	30.0	30.5	30.9	31.0	30.9	30.3	30.3
ICM40-B		30	52.9	53.9	54.4	54.7	54.4	53.5	53.5
ICM50-A	50	27	47.6	48.5	49.0	49.2	49.0	48.2	48.2
ICM50-B		46	81.1	82.6	83.5	83.9	83.5	82.1	82.1
ICM65-B	65	81	143	145	147	148	147	145	145

Correction factor for discharge temperature ($T_{disch.}$).

Discharge temperature	Correction factor
120 $^\circ\text{F}$	0.95
140 $^\circ\text{F}$	0.97
180$^\circ\text{F}$	1.00
200 $^\circ\text{F}$	1.02
210 $^\circ\text{F}$	1.02
230 $^\circ\text{F}$	1.04
250 $^\circ\text{F}$	1.05

Correction factor for ΔP ($f_{\Delta P}$)

ΔP (psi)	Correction factor
0.75	1.97
1.5	1.39
3	1.00
3.5	0.91
4	0.85
4.5	0.81

Correction factor for liquid temperature (T_{liq})

Liquid temperature	Correction factor
-10 $^\circ\text{F}$	0.48
10 $^\circ\text{F}$	0.64
30 $^\circ\text{F}$	0.88
50$^\circ\text{F}$	1.00

Nominal capacities

Discharge line

SI units

Capacity table at nominal conditions, Q_N [kW],
 $T_{liq} = 30^\circ\text{C}$,
 $\Delta p = 0.2 \text{ bar}$,
 $P_{disch.} = 8 \text{ bar}$,
 $T_{disch.} = 80^\circ\text{C}$
 Superheating = 8°C

R 134a

Type	Valve body size	K_v (m ³ /h)	Evaporating temperature [°C]						
			-40	-30	-20	-10	0	10	20
ICM20-A	20	0.6	5.7	6.0	6.3	6.5	6.8	7.0	7.3
ICM20-B		2.4	22.9	24.0	25.1	26.1	27.2	28.2	29.1
ICM20-C		4.6	43.8	45.9	48.0	50.1	52.0	54.0	55.9
ICM25-A	25	6	57.2	59.9	62.7	65.3	67.9	70.5	72.9
ICM25-B		12	114	120	125	131	136	141	146
ICM32-A	32	9	85.8	89.9	94.0	98.0	102	106	109
ICM32-B		17	162	170	178	185	192	200	206
ICM40-A	40	15	143	150	157	163	170	176	182
ICM40-B		26	248	260	272	283	294	305	316
ICM50-A	50	23	219	230	240	250	260	270	279
ICM50-B		40	381	399	418	435	453	470	486
ICM65-B	65	70	667	699	731	762	792	822	850

Correction factor for ΔP ($f_{\Delta P}$)

ΔP (bar)	Correction factor
0.05	2.00
0.1	1.41
0.2	1.00
0.3	0.82
0.4	0.71
0.5	0.63

Correction factor for discharge temperature ($T_{disch.}$)

Discharge temperature	Correction factor
50°C	0.96
60°C	0.97
80°C	1.00
90°C	1.01
100°C	1.03
110°C	1.04
120°C	1.06

Correction factor for liquid temperature (T_{liq})

Liquid temperature	Correction factor
-20°C	0.66
-10°C	0.70
0°C	0.76
10°C	0.82
20°C	0.90
30°C	1.00
40°C	1.13
50°C	1.29

US units

Capacity table at nominal conditions, Q_N [Tons of Refrigeration],
 $T_{liq} = 90^\circ\text{F}$,
 $\Delta p = 3 \text{ psi}$,
 $P_{disch.} = 120 \text{ psi}$,
 $T_{disch.} = 180^\circ\text{F}$
 Superheating = 12°F

R 134a

Type	Valve body size	C_v (USgal/min)	Evaporating temperature [°F]						
			-40	-20	0	20	40	60	80
ICM20-A	20	0.7	0.5	0.5	0.6	0.6	0.6	0.6	0.7
ICM20-B		2.8	2.0	2.1	2.3	2.4	2.5	2.6	2.7
ICM20-C		5.3	3.9	4.1	4.3	4.5	4.7	4.9	5.0
ICM25-A	25	7	5.1	5.4	5.6	5.9	6.2	6.4	6.7
ICM25-B		14	10.2	10.7	11.3	11.8	12.3	12.8	13.3
ICM32-A	32	10	7.3	7.7	8.0	8.4	8.8	9.2	9.5
ICM32-B		20	14.5	15.3	16.1	16.9	17.6	18.3	19.0
ICM40-A	40	17	12.4	13.0	13.7	14.3	15.0	15.6	16.2
ICM40-B		30	21.8	23.0	24.1	25.3	26.4	27.5	28.5
ICM50-A	50	27	19.6	20.7	21.7	22.8	23.8	24.7	25.7
ICM50-B		46	33.4	35.3	37.0	38.8	40.5	42.1	43.7
ICM65-B	65	81	58.9	62.1	65.2	68.3	71.3	74.2	77.0

Correction factor for ΔP ($f_{\Delta P}$)

ΔP (psi)	Correction factor
0.75	1.97
1.5	1.39
3	1.00
3.5	0.91
4	0.85
4.5	0.81

Correction factor for discharge temperature ($T_{disch.}$)

Discharge temperature	Correction factor
120°F	0.95
140°F	0.97
180°F	1.00
200°F	1.02
210°F	1.02
230°F	1.04
250°F	1.05

Correction factor for liquid temperature (T_{liq})

Liquid temperature	Correction factor
-10°F	0.64
10°F	0.68
30°F	0.74
50°F	0.81
70°F	0.89
90°F	1.00
110°F	1.15
130°F	1.35

Nominal capacities

Discharge line

SI units

Capacity table at nominal conditions, Q_N [kW],
 $T_{liq} = 30^\circ\text{C}$,
 $\Delta p = 0.2 \text{ bar}$,
 $P_{disch.} = 12 \text{ bar}$,
 $T_{disch.} = 80^\circ\text{C}$
 Superheating = 8°C

R 404A

Type	Valve body size	K_v (m^3/h)	Evaporating temperature [$^\circ\text{C}$]							
			-50	-40	-30	-20	-10	0	10	20
ICM20-A	20	0.6	5.3	5.7	6.0	6.4	6.7	7.1	7.4	7.6
ICM20-B		2.4	21.2	22.6	24.1	25.5	26.9	28.2	29.5	30.5
ICM20-C		4.6	40.6	43.4	46.2	48.9	51.5	54.1	56.4	58.6
ICM25-A	25	6	53.0	56.6	60.3	63.8	67.2	70.5	73.6	76.4
ICM25-B		12	106	113	121	128	134	141	147	153
ICM32-A	32	9	79.5	84.9	90.4	95.7	101	106	110	115
ICM32-B		17	150	160	171	181	190	200	209	216
ICM40-A	40	15	132	141	151	159	168	176	184	191
ICM40-B		26	230	245	261	276	291	306	319	331
ICM50-A	50	23	203	217	231	244	258	270	282	293
ICM50-B		40	353	377	402	425	448	470	491	509
ICM65-B	65	70	618	660	703	744	784	823	859	891

Correction factor for ΔP ($f_{\Delta P}$)

ΔP (bar)	Correction factor
0.05	2.00
0.1	1.41
0.2	1.00
0.3	0.82
0.4	0.71
0.5	0.63

Correction factor for discharge temperature ($T_{disch.}$).

Discharge temperature	Correction factor
50 $^\circ\text{C}$	0.96
60 $^\circ\text{C}$	0.97
80$^\circ\text{C}$	1.00
90 $^\circ\text{C}$	1.01
100 $^\circ\text{C}$	1.03
110 $^\circ\text{C}$	1.04
120 $^\circ\text{C}$	1.06

Correction factor for liquid temperature (T_{liq})

Liquid temperature	Correction factor
-20 $^\circ\text{C}$	0.55
-10 $^\circ\text{C}$	0.60
0 $^\circ\text{C}$	0.66
10 $^\circ\text{C}$	0.74
20 $^\circ\text{C}$	0.85
30$^\circ\text{C}$	1.00
40 $^\circ\text{C}$	1.23
50 $^\circ\text{C}$	1.68

US units

Capacity table at nominal conditions, Q_N [Tons of Refrigeration],
 $T_{liq} = 90^\circ\text{F}$,
 $\Delta p = 3 \text{ psi}$,
 $P_{disch.} = 120 \text{ psi}$,
 $T_{disch.} = 180^\circ\text{F}$
 Superheating = 12°F

R 404A

Typ	Valve body size	C_v (USgal/min)	Evaporating temperature [$^\circ\text{F}$]							
			-60	-40	-20	0	20	40	60	80
ICM20-A	20	0.7	0.5	0.5	0.5	0.6	0.6	0.6	0.7	0.7
ICM20-B		2.8	1.8	2.0	2.1	2.3	2.4	2.5	2.7	2.8
ICM20-C		5.3	3.5	3.7	4.0	4.3	4.6	4.8	5.0	5.2
ICM25-A	25	7	4.6	5.0	5.3	5.7	6.0	6.4	6.6	6.9
ICM25-B		14	9.2	9.9	10.6	11.4	12.0	12.7	13.3	13.8
ICM32-A	32	10	6.5	7.1	7.6	8.1	8.6	9.1	9.5	9.9
ICM32-B		20	13.1	14.1	15.2	16.2	17.2	18.1	19.0	19.7
ICM40-A	40	17	11.1	12.0	12.9	13.8	14.6	15.4	16.1	16.8
ICM40-B		30	19.6	21.2	22.8	24.3	25.8	27.2	28.5	29.6
ICM50-A	50	27	17.7	19.1	20.5	21.9	23.2	24.5	25.6	26.6
ICM50-B		46	30.1	32.5	35.0	37.3	39.6	41.7	43.7	45.4
ICM65-B	65	81	53.0	57.3	61.6	65.7	69.7	73.5	76.9	79.9

Correction factor for ΔP ($f_{\Delta P}$)

ΔP (psi)	Correction factor
0.75	1.97
1.5	1.39
3	1.00
3.5	0.91
4	0.85
4.5	0.81

Correction factor for discharge temperature ($T_{disch.}$).

Discharge temperature	Correction factor
120 $^\circ\text{F}$	0.95
140 $^\circ\text{F}$	0.97
180$^\circ\text{F}$	1.00
200 $^\circ\text{F}$	1.02
210 $^\circ\text{F}$	1.02
230 $^\circ\text{F}$	1.04
250 $^\circ\text{F}$	1.05

Correction factor for liquid temperature (T_{liq})

Liquid temperature	Correction factor
-10 $^\circ\text{F}$	0.52
10 $^\circ\text{F}$	0.57
30 $^\circ\text{F}$	0.63
50 $^\circ\text{F}$	0.72
70 $^\circ\text{F}$	0.83
90$^\circ\text{F}$	1.00
110 $^\circ\text{F}$	1.29
130 $^\circ\text{F}$	1.92

Nominal capacities

Discharge line

SI units

Capacity table at nominal conditions, Q_N [kW],
 $T_{liq} = 30^\circ\text{C}$,
 $\Delta p = 0.2 \text{ bar}$,
 $P_{disch.} = 12 \text{ bar}$,
 $T_{disch.} = 80^\circ\text{C}$
 Superheating = 8°C

R 22

Type	Valve body size	K_v (m^3/h)	Evaporating temperature [$^\circ\text{C}$]							
			-50	-40	-30	-20	-10	0	10	20
ICM20-A	20	0.6	2.3	2.3	2.4	2.5	2.5	2.6	2.7	2.7
ICM20-B		2.4	9.1	9.3	9.6	9.9	10.1	10.4	10.6	10.8
ICM20-C		4.6	17.3	17.9	18.4	19.0	19.5	19.9	20.4	20.8
ICM25-A	25	6	22.6	23.4	24.0	24.7	25.4	26.0	26.6	27.1
ICM25-B		12	45.3	46.7	48.1	49.5	50.7	51.9	53.1	54.2
ICM32-A	32	9	33.9	35.0	36.1	37.1	38.1	39.0	39.9	40.6
ICM32-B		17	64.1	66.2	68.1	70.1	71.9	73.6	75.3	76.7
ICM40-A	40	15	56.6	58.4	60.1	61.8	63.4	64.9	66.4	67.7
ICM40-B		26	98.1	101	104	107	110	113	115	117
ICM50-A	50	23	86.7	89.5	92.2	94.8	97.3	100	102	104
ICM50-B		40	151	156	160	165	169	173	177	181
ICM65-B	65	70	264	273	281	289	296	303	310	316

Correction factor for ΔP ($f_{\Delta P}$)

ΔP (bar)	Correction factor
0.2	1.00
0.25	0.89
0.3	0.82
0.4	0.71
0.5	0.63
0.6	0.58

Correction factor for discharge temperature ($T_{disch.}$).

Discharge temperature	Correction factor
50 $^\circ\text{C}$	0.96
60 $^\circ\text{C}$	0.97
80$^\circ\text{C}$	1.00
90 $^\circ\text{C}$	1.01
100 $^\circ\text{C}$	1.03
110 $^\circ\text{C}$	1.04
120 $^\circ\text{C}$	1.06

Correction factor for liquid temperature (T_{liq}).

Liquid temperature	Correction factor
-20 $^\circ\text{C}$	0.71
-10 $^\circ\text{C}$	0.75
0 $^\circ\text{C}$	0.80
10 $^\circ\text{C}$	0.86
20 $^\circ\text{C}$	0.92
30$^\circ\text{C}$	1.00
40 $^\circ\text{C}$	1.09
50 $^\circ\text{C}$	1.22

R 22

US units

Capacity table at nominal conditions, Q_N [Tons of Refrigeration],
 $T_{liq} = 90^\circ\text{F}$,
 $\Delta p = 3 \text{ psi}$,
 $P_{disch.} = 120 \text{ psi}$,
 $T_{disch.} = 180^\circ\text{F}$
 Superheating = 12°F

Typ	Valve body size	C_v (USgal/min)	Evaporating temperature [$^\circ\text{F}$]							
			-60	-40	-20	0	20	40	60	80
ICM20-A	20	0.7	0.6	0.7	0.7	0.7	0.7	0.7	0.8	0.8
ICM20-B		2.8	2.6	2.6	2.7	2.8	2.9	3.0	3.0	3.1
ICM20-C		5.3	4.8	5.0	5.2	5.3	5.5	5.6	5.8	5.9
ICM25-A	25	7	6.4	6.6	6.8	7.1	7.3	7.4	7.6	7.8
ICM25-B		14	12.8	13.2	13.7	14.1	14.5	14.9	15.2	15.6
ICM32-A	32	10	9.1	9.5	9.8	10.1	10.4	10.6	10.9	11.1
ICM32-B		20	18.2	18.9	19.6	20.2	20.7	21.3	21.8	22.2
ICM40-A	40	17	15.5	16.1	16.6	17.1	17.6	18.1	18.5	18.9
ICM40-B		30	27.4	28.4	29.3	30.3	31.1	31.9	32.7	33.3
ICM50-A	50	27	24.6	25.5	26.4	27.2	28.0	28.7	29.4	30.0
ICM50-B		46	42.0	43.5	45.0	46.4	47.7	49.0	50.1	51.1
ICM65-B	65	81	73.9	76.6	79.2	81.7	84.0	86.2	88.2	90.0

Correction factor for ΔP ($f_{\Delta P}$)

ΔP (psi)	Correction factor
3	1.00
4	0.87
5	0.79
6	0.72
7	0.66
8	0.62

Correction factor for discharge temperature ($T_{disch.}$).

Discharge temperature	Correction factor
120 $^\circ\text{F}$	0.95
140 $^\circ\text{F}$	0.97
180$^\circ\text{F}$	1.00
200 $^\circ\text{F}$	1.02
210 $^\circ\text{F}$	1.02
230 $^\circ\text{F}$	1.04
250 $^\circ\text{F}$	1.05

Correction factor for liquid temperature (T_{liq}).

Liquid temperature	Correction factor
-10 $^\circ\text{F}$	0.73
10 $^\circ\text{F}$	0.77
30 $^\circ\text{F}$	0.82
50 $^\circ\text{F}$	0.87
70 $^\circ\text{F}$	0.93
90$^\circ\text{F}$	1.00
110 $^\circ\text{F}$	1.09
130 $^\circ\text{F}$	1.20

Nominal capacities

Expansion - ICM

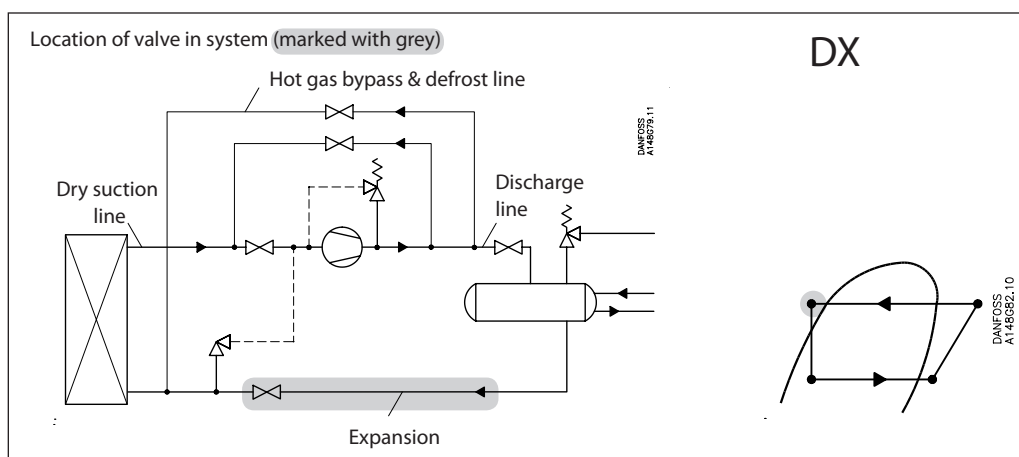
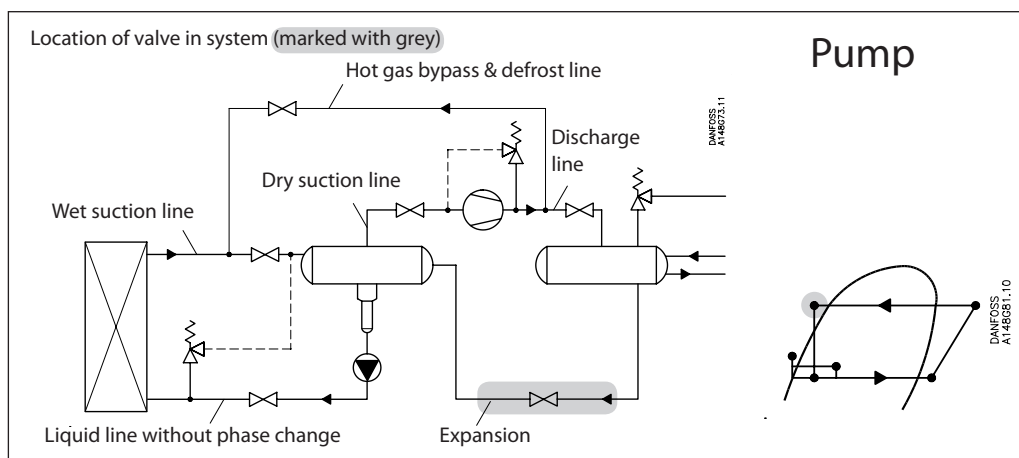

Correction factors

When dimensioning, multiply the evaporator capacity by a correction factor k dependent on the subcooling Δt_{sub} just ahead of the valve. The corrected capacity* can then be found in the capacity table.

Correction factors for subcooling

Subcooling K	2	4	10	15	20	25	30	35	40
R717	1.01	1	0.98	0.96	0.94	0.92	0.91	0.89	0.87
R744	1.02	1	0.95	0.90	0.86	0.82	0.79	0.75	0.73
R134a	1.03	1	0.93	0.88	0.84	0.80	0.76	0.73	0.70
R404A	1.04	1	0.91	0.83	0.78	0.73	0.68	0.65	0.61
R22	1.03	1	0.94	0.90	0.87	0.83	0.80	0.77	0.74

*The capacity table is based on nominal conditions of subcooling just ahead of the valve of 4°K.

Calculation example:

An application has the following operating conditions:

Refrigerant R717
 $T_e = -10^\circ\text{C}$
 $T_c = +30^\circ\text{C}$
 $Q_0 = 1500 \text{ kW}$
 $\Delta t_{sub} = 20^\circ\text{K}$

Correction factor for subcooling: 0.94

Pressure drop across the valve:
 11.7 bar - 2.9 bar = 8.8 bar

Corrected capacity: $1500 \times 0.94 = 1410 \text{ kW}$

From the R717 capacity table ICM 20-C is selected with Q_{nom} capacity 1990 kW at 8 bar.

Expansion

Capacities for nominal conditions, Q_n (kW)

R 717

Type		Pressure drop across valve Δp bar						
		1	2	4	8	12	16	
Evaporating temperature 10°C								
ICM20-A	DN20	0.6	85.9	119	163	217	253	279
ICM20-B	DN20	2.4	498	686	930	1230	1435	1587
ICM20-C	DN20	4.6	824	1124	1507	1990	2310	2550
ICM25-A	DN25	6	1274	1739	2337	3080	3575	3970
ICM32-A	DN32	9	1834	2515	3400	4490	5220	5775
ICM40-A	DN40	15	3410	4630	6200	8150	9450	10450
ICM50-A	DN50	23	5960	8050	10750	14100	16300	18100
Evaporating temperature -10°C								
ICM20-A	DN20	0.6	92	127	170	224	258	284
ICM20-B	DN20	2.4	527	715	955	1253	1452	1594
ICM20-C	DN20	4.6	859	1152	1520	1990	2310	2550
ICM25-A	DN25	6	1332	1780	2360	3090	3590	3960
ICM32-A	DN32	9	1930	2600	3450	4520	5240	5780
ICM40-A	DN40	15	3550	4715	6220	8140	9450	10430
ICM50-A	DN50	23	6150	8150	10700	14000	16300	18000
Evaporating temperature -30°C								
ICM20-A	DN20	0.6	96	130	173	225	258	282
ICM20-B	DN20	2.4	532	716	950	1240	1435	1580
ICM20-C	DN20	4.6	840	1111	1480	1950	2270	2505
ICM25-A	DN25	6	1310	1740	2310	3030	3530	3880
ICM32-A	DN32	9	1920	2560	3400	4460	5150	5700
ICM40-A	DN40	15	3430	4530	6030	7950	9250	10200
ICM50-A	DN50	23	5900	7800	10350	13650	15900	17600
Evaporating temperature -50°C								
ICM20-A	DN20	0.6	97.5	131	172	222	253	276
ICM20-B	DN20	2.4	512	690	925	1210	1400	1535
ICM20-C	DN20	4.6	780	1055	1425	1890	2200	2430
ICM25-A	DN25	6	1220	1650	2220	2950	3420	3780
ICM32-A	DN32	9	1810	2450	3280	4325	5030	5540
ICM40-A	DN40	15	3170	4280	5800	7710	8950	9900
ICM50-A	DN50	23	5430	7350	9900	13200	15400	17100

		Pressure drop across valve Δp bar					
		1	2	4	8	12	16
Evaporating temperature 0°C							
		90	123	167	221	256	282
		515	705	950	1245	1450	1594
		850	1145	1525	2000	2320	2560
		1310	1773	2370	3100	3600	3980
		1890	2580	3450	4530	5250	5790
		3500	4700	6250	8170	9480	10450
		6100	8150	10800	14100	16300	18100
Evaporating temperature -20°C							
		94.5	129	172	225	258	284
		535	718	957	1250	1450	1594
		860	1140	1505	1975	2290	2525
		1332	1770	2345	3070	3570	3940
		1935	2590	3440	4510	5220	5750
		3520	4650	6140	8050	9350	10350
		6070	8000	10550	13850	16100	17800
Evaporating temperature -40°C							
		97	131	173	224	256	280
		527	705	940	1230	1420	1555
		815	1085	1450	1920	2230	2470
		1270	1690	2270	2990	3480	3830
		1870	2500	3350	4400	5100	5630
		3300	4400	5900	7820	9120	10100
		5670	7550	10150	13400	15700	17400

Expansion

Capacities for nominal conditions, Q_n (TR)

R 717

Type		Pressure drop across valve Δp psi						
		15	30	60	120	180	240	
Evaporating temperature 60°F								
ICM20-A	DN20	0.7	24.5	33.9	46.3	61.8	72	79.3
ICM20-B	DN20	2.8	142	196	265	352	410	451
ICM20-C	DN20	5.3	235	321	432	570	660	730
ICM25-A	DN25	7	363	497	670	880	1025	1130
ICM32-A	DN32	10	523	720	970	1280	1490	1645
ICM40-A	DN40	17	975	1325	1780	2330	2705	3000
ICM50-A	DN50	27	1695	2310	3070	4030	4690	5170
Evaporating temperature 20°F								
ICM20-A	DN20	0.7	26.3	36.2	48.8	64	74	81.4
ICM20-B	DN20	2.8	151	206	275	360	416	459
ICM20-C	DN20	5.3	248	332	439	574	665	734
ICM25-A	DN25	7	383	515	681	888	1030	1135
ICM32-A	DN32	10	553	746	993	1299	1510	1657
ICM40-A	DN40	17	1020	1360	1795	2346	2715	3005
ICM50-A	DN50	27	1770	2350	3100	4040	4680	5170
Evaporating temperature -20°F								
ICM20-A	DN20	0.7	27.7	37.5	50	64.5	74	81
ICM20-B	DN20	2.8	154	206	274	357	413	454
ICM20-C	DN20	5.3	244	323	428	560	653	720
ICM25-A	DN25	7	380	503	665	875	1015	1120
ICM32-A	DN32	10	555	740	978	1285	1485	1635
ICM40-A	DN40	17	995	1315	1740	2290	2660	2945
ICM50-A	DN50	27	1720	2255	2985	3930	4570	5050
Evaporating temperature -60°F								
ICM20-A	DN20	0.7	28.1	37.6	49.5	63.7	72.5	79
ICM20-B	DN20	2.8	147	199	266	347	400	440
ICM20-C	DN20	5.3	225	304	410	544	630	695
ICM25-A	DN25	7	352	475	640	845	980	1080
ICM32-A	DN32	10	520	703	943	1246	1440	1585
ICM40-A	DN40	17	910	1230	1660	2210	2570	2850
ICM50-A	DN50	27	1560	2110	2850	3800	4430	4900

		Pressure drop across valve Δp psi					
		15	30	60	120	180	240
Evaporating temperature 40°F							
		25.3	35	47.6	63	73	80.4
		147	201	271	358	415	458
		243	328	438	574	665	735
		375	510	680	888	1030	1140
		539	735	985	1294	1500	1655
		1000	1350	1800	2344	2715	3010
		1745	2350	3100	4050	4700	5200
Evaporating temperature 0°F							
		27.1	37	49.5	64.5	74.3	81.5
		154	207	276	360	416	458
		249	330	435	570	660	728
		385	513	678	884	1025	1130
		560	747	990	1293	1500	1650
		1022	1345	1775	2325	2700	2970
		1770	2320	3050	4000	4650	5130
Evaporating temperature -40°F							
		28	37.8	50	64.3	73.5	79.9
		152	203	270	353	408	446
		235	313	418	553	642	710
		366	488	653	860	1000	1100
		540	723	965	1265	1465	1610
		955	1270	1700	2250	2615	2900
		1640	2180	2920	3870	4500	4990

Expansion

Capacities for nominal conditions, Q_n (kW)

Type	Pressure drop across valve Δp bar					
	1	2	4	8	12	16

Evaporating temperature 10°C								
ICM20-A	DN20	0.6	18.7	26.2	36.1	48.3	56	61
ICM20-B	DN20	2.4	109	152	209	280	324	353
ICM20-C	DN20	4.6	180	251	347	465	535	583
ICM25-A	DN25	6	277	389	535	718	826	900
ICM32-A	DN32	9	400	560	770	1030	1190	1300
ICM40-A	DN40	15	743	1040	1435	1920	2215	2400
ICM50-A	DN50	23	1295	1810	2500	3340	3850	4180

Evaporating temperature -10°C								
ICM20-A	DN20	0.6	24.7	34.5	47.5	63.6	74	81
ICM20-B	DN20	2.4	143	200	275	368	428	470
ICM20-C	DN20	4.6	238	331	455	608	705	770
ICM25-A	DN25	6	368	513	705	940	1090	1195
ICM32-A	DN32	9	528	735	1015	1355	1570	1720
ICM40-A	DN40	15	980	1370	1880	2510	2910	3180
ICM50-A	DN50	23	1710	2380	3280	4380	5050	5550

Evaporating temperature -30°C								
ICM20-A	DN20	0.6	29.7	41	56.3	75	86.8	95
ICM20-B	DN20	2.4	172	238	325	432	500	545
ICM20-C	DN20	4.6	285	395	536	710	820	895
ICM25-A	DN25	6	440	610	828	1100	1270	1380
ICM32-A	DN32	9	632	880	1195	1585	1830	2000
ICM40-A	DN40	15	1175	1630	2220	2920	3370	3680
ICM50-A	DN50	23	2050	2850	3850	5080	5850	6400

Evaporating temperature -50°C								
ICM20-A	DN20	0.6	33.3	46	62.5	82.5	94.8	103
ICM20-B	DN20	2.4	193	266	359	472	540	588
ICM20-C	DN20	4.6	319	438	587	765	880	955
ICM25-A	DN25	6	494	678	910	1190	1360	1480
ICM32-A	DN32	9	710	980	1320	1720	1980	2155
ICM40-A	DN40	15	1320	1810	2420	3150	3610	3940
ICM50-A	DN50	23	2300	3150	4210	5450	6250	6800

Pressure drop across valve Δp bar					
1	2	4	8	12	16

Evaporating temperature 0°C					
22.4	31	42.5	56.8	66	72
130	179	246	329	381	417
215	297	408	542	630	686
333	460	630	838	975	1065
478	660	905	1210	1400	1530
890	1230	1680	2250	2600	2830
1550	2140	2940	3900	4530	4750

Evaporating temperature -20°C					
27.1	37.8	52	69.6	81	88.5
157	219	302	402	468	512
260	363	497	665	770	840
402	563	770	1025	1190	1300
580	810	1110	1480	1715	1880
1075	1500	2060	2740	3160	3470
1870	2620	3580	4750	5500	6030

Evaporating temperature -40°C					
32.1	44	60	79	91.2	99.5
186	256	345	455	525	571
308	422	570	745	855	930
478	655	880	1155	1325	1444
685	940	1270	1670	1915	2090
1275	1750	2350	3060	3530	3830
2220	3050	4080	5330	6100	6650

Expansion

Capacities for nominal conditions, Q_n (TR)

Type	Pressure drop across valve Δp psi					
	15	30	60	120	180	240

Evaporating temperature 60°F								
ICM20-A	DN20	0.7	4.8	6.7	9.2	12.3	14.2	15.3
ICM20-B	DN20	2.8	27.8	39	53.7	71.5	82	88.8
ICM20-C	DN20	5.3	46	64.5	89	118	136	146
ICM25-A	DN25	7	71.1	100	137	183	210	226
ICM32-A	DN32	10	102	144	198	264	303	327
ICM40-A	DN40	17	191	267	368	490	561	605
ICM50-A	DN50	27	332	465	640	855	976	1055

Evaporating temperature 20°F								
ICM20-A	DN20	0.7	6.8	9.6	13.2	17.7	20.5	22.4
ICM20-B	DN20	2.8	39.9	55.7	76.5	102	118	130
ICM20-C	DN20	5.3	66	92	126	169	195	214
ICM25-A	DN25	7	102	142	196	261	303	330
ICM32-A	DN32	10	147	205	281	376	437	476
ICM40-A	DN40	17	273	381	524	699	805	880
ICM50-A	DN50	27	475	663	910	1215	1400	1535

Evaporating temperature -20°F								
ICM20-A	DN20	0.7	8.4	11.7	16	21.4	24.7	27
ICM20-B	DN20	2.8	48.9	68	93	123	142	155
ICM20-C	DN20	5.3	81	112	153	203	233	255
ICM25-A	DN25	7	125	174	237	313	362	395
ICM32-A	DN32	10	180	250	341	453	523	570
ICM40-A	DN40	17	335	464	633	835	960	1050
ICM50-A	DN50	27	584	810	1100	1450	1670	1820

Evaporating temperature -60°F								
ICM20-A	DN20	0.7	9.6	13.3	18.1	23.7	27.3	29.5
ICM20-B	DN20	2.8	56	77	104	136	156	169
ICM20-C	DN20	5.3	92.8	127	170	221	253	275
ICM25-A	DN25	7	143	197	263	342	391	425
ICM32-A	DN32	10	206	284	380	496	568	618
ICM40-A	DN40	17	383	524	700	907	1040	1130
ICM50-A	DN50	27	667	915	1215	1570	1800	1950

Pressure drop across valve Δp psi					
15	30	60	120	180	240

Evaporating temperature 40°C					
5.8	8.2	11.3	15.2	17.6	19.2
33.9	47.6	66	88.3	102	111
56	79	109	146	169	184
87	122	169	226	261	285
125	176	242	325	376	410
232	326	450	603	699	760
405	570	785	1050	1215	1320

Evaporating temperature 0°C					
7.7	10.7	14.7	19.7	22.8	25
44.7	62.3	85.5	114	132	144
74.3	103	141	188	217	237
115	159	218	290	335	367
165	230	315	418	485	528
307	426	585	775	895	975
535	745	1015	1350	1555	1700

Evaporating temperature -40°C					
9.1	12.6	17.2	22.7	26.2	28.5
53	73.3	99	131	150	164
87.8	121	163	214	245	267
135	187	253	331	380	414
195	270	365	480	549	600
362	500	675	878	1010	1100
633	870	1170	1530	1750	1900

Expansion

Capacities for nominal conditions, Q_n (kW)

R 134a

Type			Pressure drop across valve Δp bar					
			1	2	4	8	12	16
Evaporating temperature 10°C								
ICM20-A	DN20	0.6	19.4	26	33.6	40.5	42.7	42.5
ICM20-B	DN20	2.4	112	149	192	230	243	242
ICM20-C	DN20	4.6	184	243	310	370	392	391
ICM25-A	DN25	6	285	377	480	575	607	606
ICM32-A	DN32	9	410	545	699	835	885	883
ICM40-A	DN40	15	760	1000	1270	1520	1610	1605
ICM50-A	DN50	23	1320	1730	2200	2620	2770	2785

Pressure drop across valve Δp bar						
1	2	4	8	12	16	
Evaporating temperature 0°C						
20.1	26.8	34.3	40.8	42.5	42.1	
116	153	194	231	242	240	
189	247	311	370	389	388	
292	383	482	575	604	602	
422	555	703	835	880	875	
775	1015	1270	1515	1596	1590	
1350	1750	2200	2610	2750	2740	

Evaporating temperature -10°C								
ICM20-A	DN20	0.6	20.7	27.4	34.5	40.5	42	41.5
ICM20-B	DN20	2.4	118	154	194	229	238	235
ICM20-C	DN20	4.6	191	247	310	365	381	379
ICM25-A	DN25	6	296	383	481	568	593	587
ICM32-A	DN32	9	430	559	702	826	865	855
ICM40-A	DN40	15	785	1013	1265	1490	1565	1550
ICM50-A	DN50	23	1360	1740	2180	2570	2700	2670

Evaporating temperature -20°C						
21.1	27.6	34.5	40	41.1	40.1	
119	154	193	225	233	228	
190	244	305	357	372	365	
295	380	474	555	575	568	
430	555	695	810	840	826	
775	995	1240	1460	1520	1495	
1340	1710	2130	2510	2620	2590	

Evaporating temperature -30°C								
ICM20-A	DN20	0.6	21.3	27.6	34.2	39.1	40	38.7
ICM20-B	DN20	2.4	118	152	189	219	225	218
ICM20-C	DN20	4.6	186	238	297	347	357	350
ICM25-A	DN25	6	290	372	463	540	555	545
ICM32-A	DN32	9	425	545	680	790	812	792
ICM40-A	DN40	15	760	970	1210	1415	1465	1430
ICM50-A	DN50	23	1305	1670	2080	2440	2530	2480

Evaporating temperature -40°C						
21.4	27.5	33.6	38	38.3	36.8	
116	149	184	211	216	208	
180	231	288	335	342	333	
280	361	448	520	532	516	
415	532	660	760	780	755	
730	940	1175	1360	1410	1358	
1260	1610	2010	2350	2420	2350	

Expansion

Capacities for nominal conditions, Q_n (TR)

R 134a

Type			Pressure drop across valve Δp psi					
			15	30	60	120	180	240
Evaporating temperature 60°F								
ICM20-A	DN20	0.7	5.5	7.3	9.5	11.4	12	11.9
ICM20-B	DN20	2.8	31.5	42	54.1	65	68.5	68.2
ICM20-C	DN20	5.3	52	69	88	105	111	111
ICM25-A	DN25	7	80.3	106	136	163	172	171
ICM32-A	DN32	10	116	154	198	237	250	249
ICM40-A	DN40	17	214	284	360	431	455	454
ICM50-A	DN50	27	373	493	625	745	787	787

Pressure drop across valve Δp psi						
15	30	60	120	180	240	
Evaporating temperature 40°F						
5.7	7.6	9.7	11.6	12.1	11.9	
32.7	43.5	55.3	65.8	68.8	68	
53.6	70.5	89	106	111	110	
83	109	138	164	172	170	
120	158	201	238	250	248	
222	289	364	432	455	452	
385	500	630	745	785	780	

Evaporating temperature 20°F								
ICM20-A	DN20	0.7	5.9	7.8	9.9	11.6	12	11.8
ICM20-B	DN20	2.8	33.6	44.3	55.5	65.5	68	66.7
ICM20-C	DN20	5.3	54.8	71	88.5	105	109	108
ICM25-A	DN25	7	85	110	138	162	169	167
ICM32-A	DN32	10	123	160	201	237	247	243
ICM40-A	DN40	17	225	291	363	428	447	442
ICM50-A	DN50	27	390	503	625	737	770	760

Evaporating temperature 0°F						
6	7.9	9.9	11.4	11.7	11.4	
34.1	44.4	55.4	64.2	66.2	64.5	
54.8	70.2	87.5	102	106	104	
85	109	136	159	164	161	
124	160	199	232	240	235	
224	287	357	418	433	425	
387	495	615	720	747	735	

Evaporating temperature -20°F								
ICM20-A	DN20	0.7	6.1	7.9	9.8	11.2	11.3	10.9
ICM20-B	DN20	2.8	34	43.9	54.3	62.6	64	61.8
ICM20-C	DN20	5.3	53.5	68.5	85.3	99	102	99
ICM25-A	DN25	7	83.5	107	132	154	158	154
ICM32-A	DN32	10	122	157	195	225	231	224
ICM40-A	DN40	17	219	280	347	405	416	405
ICM50-A	DN50	27	377	480	597	695	720	710

Evaporating temperature -40°F						
6.1	7.8	9.6	10.8	10.8	10.3	
33.3	42.7	52.8	60.1	61	58.5	
51.7	66.6	82.5	95	97	93.7	
80.7	103.3	128	148	151	145	
119	153	189	217	220	212	
211	270	336	388	397	383	
362	463	575	667	685	660	

Expansion

Capacities for nominal conditions, Q_n (kW)

Type	Pressure drop across valve Δp bar					
	1	2	4	8	12	16

Pressure drop across valve Δp bar					
1	2	4	8	12	16

Evaporating temperature 10°C

ICM20-A	DN20	0.6	15.7	21.3	27.8	33.8	35.3	34.5
ICM20-B	DN20	2.4	91	123	160	194	203	198
ICM20-C	DN20	4.6	150	203	263	315	330	322
ICM25-A	DN25	6	233	313	406	490	510	500
ICM32-A	DN32	9	335	452	589	710	740	723
ICM40-A	DN40	15	621	835	1080	1300	1360	1323
ICM50-A	DN50	23	1085	1455	1880	2250	2350	2300

Evaporating temperature 0°C

16.6	22.5	29.3	35.2	36.8	35.9
96.5	130	168	201	210	205
159	213	273	327	341	333
246	329	423	508	528	518
354	475	612	733	766	750
659	876	1123	1340	1400	1370
1145	1525	1950	2330	2430	2380

Evaporating temperature -10°C

ICM20-A	DN20	0.6	17.4	23.5	30.3	36.1	37.5	36.5
ICM20-B	DN20	2.4	101	135	173	206	214	209
ICM20-C	DN20	4.6	166	220	280	333	345	338
ICM25-A	DN25	6	257	340	435	515	535	525
ICM32-A	DN32	9	370	493	629	748	778	760
ICM40-A	DN40	15	685	904	1150	1360	1420	1390
ICM50-A	DN50	23	1190	1570	1990	2350	2450	2400

Evaporating temperature -20°C

18.2	24.3	31	36.5	37.7	36.5
105	139	176	207	214	208
172	225	283	333	345	335
265	348	439	515	535	520
384	506	640	750	778	755
706	920	1160	1360	1410	1375
1230	1600	2000	2350	2435	2380

Evaporating temperature -30°C

ICM20-A	DN20	0.6	18.7	24.7	31.3	36.5	37.3	35.8
ICM20-B	DN20	2.4	107	140	176	205	211	204
ICM20-C	DN20	4.6	173	225	281	329	338	328
ICM25-A	DN25	6	269	349	437	510	525	508
ICM32-A	DN32	9	389	508	637	745	765	742
ICM40-A	DN40	15	711	922	1150	1345	1385	1340
ICM50-A	DN50	23	1235	1590	1980	2320	2390	2320

Evaporating temperature -40°C

19.2	25	31.3	35.8	36.3	34.7
109	140	174	202	205	197
173	221	276	320	328	316
269	345	428	499	510	490
393	503	628	730	745	715
711	902	1130	1310	1340	1295
1225	1555	1940	2255	2320	2240

Evaporating temperature -50°C

ICM20-A	DN20	0.6	19.5	25	30.9	35	35.1	33.2
ICM20-B	DN20	2.4	108	138	171	196	198	188
ICM20-C	DN20	4.6	170	215	268	310	315	301
ICM25-A	DN25	6	265	335	418	484	490	468
ICM32-A	DN32	9	388	493	613	705	715	680
ICM40-A	DN40	15	695	875	1090	1270	1290	1230
ICM50-A	DN50	23	1195	1505	1880	2180	2230	2130

Expansion

Capacities for nominal conditions, Q_n (TR)

Type	Pressure drop across valve Δp psi					
	15	30	60	120	180	240

Pressure drop across valve Δp psi					
15	30	60	120	180	240

Evaporating temperature 60°F

ICM20-A	DN20	0.7	4.4	5.9	7.7	9.3	9.7	9.3
ICM20-B	DN20	2.8	25.2	34.1	44.5	53.5	55.5	53.8
ICM20-C	DN20	5.3	41.8	56.3	73	87.5	91	87.5
ICM25-A	DN25	7	64.5	87	113	135	141	136
ICM32-A	DN32	10	93	125	163	196	204	197
ICM40-A	DN40	17	173	233	300	360	373	360
ICM50-A	DN50	27	300	405	522	625	647	625

Evaporating temperature 40°F

4.7	6.3	8.2	9.9	10.2	9.9
27.2	36.5	47.3	56.5	58.8	57
45	60	77	92	95.5	92.5
69.5	93	119	143	148	144
100	134	173	207	215	208
186	248	318	377	393	381
325	431	550	655	680	660

Evaporating temperature 20°F

ICM20-A	DN20	0.7	4.9	6.6	8.6	10.2	10.6	10.2
ICM20-B	DN20	2.8	28.7	38.4	49.1	58.2	60.5	58.5
ICM20-C	DN20	5.3	47.3	62.6	79.8	94.5	97.5	94.7
ICM25-A	DN25	7	73	97	123	146	151	147
ICM32-A	DN32	10	105	140	179	212	220	213
ICM40-A	DN40	17	195	259	327	387	402	389
ICM50-A	DN50	27	340	448	567	670	694	675

Evaporating temperature 0°F

5.2	6.9	8.8	10.4	10.6	10.3
29.9	39.5	50.3	59	60.6	58.5
49	64.3	81	95	98	94.5
76	99.5	125	147	152	147
109	144	183	214	221	214
202	264	332	389	401	389
352	457	573	672	694	672

Evaporating temperature -20°F

ICM20-A	DN20	0.7	5.4	7.1	8.9	10.4	10.5	10.1
ICM20-B	DN20	2.8	30.8	40.2	50.5	58.7	60	57.5
ICM20-C	DN20	5.3	50	64.5	80.5	93.5	96	92.5
ICM25-A	DN25	7	77.5	100	125	145	149	143
ICM32-A	DN32	10	112	146	183	212	217	209
ICM40-A	DN40	17	205	265	330	383	394	380
ICM50-A	DN50	27	355	457	567	660	678	655

Evaporating temperature -40°F

5.5	7.2	8.9	10.2	10.3	9.7
31.2	40.2	50	57.5	58	55.3
50	63.6	79	91.5	93	89
77.5	99	123	142	144	138
113	144	180	207	211	201
204	259	323	373	380	363
353	447	555	643	657	630

Evaporating temperature -60°F

ICM20-A	DN20	0.7	5.6	7.1	8.8	9.9	9.9	9.3
ICM20-B	DN20	2.8	31.1	39.5	48.8	55.6	55.6	52.2
ICM20-C	DN20	5.3	49	61.5	76.7	87.8	89	84
ICM25-A	DN25	7	76.3	96	119	137	138	130
ICM32-A	DN32	10	111	141	175	200	201	190
ICM40-A	DN40	17	200	250	312	360	363	343
ICM50-A	DN50	27	344	430	535	620	628	595

Expansion

Capacities for nominal conditions, Q_n (kW)

R 22

Type		Pressure drop across valve Δp bar						
		1	2	4	8	12	16	
Evaporating temperature 10°C								
ICM20-A	DN20	0.6	20.1	27.6	36.8	46.7	51.7	54.2
ICM20-B	DN20	2.4	117	160	212	268	297	312
ICM20-C	DN20	4.6	193	263	346	435	482	505
ICM25-A	DN25	6	299	406	535	675	746	785
ICM32-A	DN32	9	430	585	777	980	1085	1140
ICM40-A	DN40	15	798	1080	1420	1790	1980	2080
ICM50-A	DN50	23	1390	1880	2470	3100	3430	3600

		Pressure drop across valve Δp bar						
		1	2	4	8	12	16	
Evaporating temperature 0°C								
		21.1	28.8	38.1	48	53	55.4	
		122	166	218	274	303	316	
		201	271	355	443	490	513	
		312	420	550	687	760	795	
		448	606	798	998	1100	1155	
		830	1115	1460	1820	2005	2110	
		1450	1940	2530	3150	3480	3650	

		Evaporating temperature -10°C						
		0.6	2.4	4.6	6	9	15	
ICM20-A	DN20	0.6	21.9	29.8	39	48.8	53.7	55.8
ICM20-B	DN20	2.4	126	170	223	278	305	318
ICM20-C	DN20	4.6	208	277	360	448	493	514
ICM25-A	DN25	6	321	430	557	695	764	796
ICM32-A	DN32	9	463	621	809	1010	1110	1157
ICM40-A	DN40	15	855	1140	1472	1830	2012	2112
ICM50-A	DN50	23	1490	1970	2550	3170	3480	3650

		Evaporating temperature -20°C					
		22.7	30.5	39.8	49.3	53.7	55.7
		130	174	225	279	305	317
		212	280	361	447	490	510
		328	435	559	693	760	792
		475	630	815	1012	1105	1151
		870	1150	1475	1830	2005	2100
		1510	1980	2550	3150	3460	3630

		Evaporating temperature -30°C						
		0.6	2.4	4.6	6	9	15	
ICM20-A	DN20	0.6	23.2	31	40	49.3	53.5	55.3
ICM20-B	DN20	2.4	132	175	225	277	302	313
ICM20-C	DN20	4.6	212	279	357	443	485	505
ICM25-A	DN25	6	329	433	556	685	752	783
ICM32-A	DN32	9	478	631	812	1000	1095	1140
ICM40-A	DN40	15	873	1140	1465	1810	1980	2070
ICM50-A	DN50	23	1510	1970	2520	3110	3420	3560

		Evaporating temperature -40°C					
		23.6	31.3	40.1	48.8	52.8	54.3
		133	174	223	274	298	308
		210	275	353	436	475	495
		327	428	550	676	740	765
		478	626	805	990	1075	1120
		860	1120	1440	1780	1940	2020
		1480	1930	2480	3070	3350	3500

		Evaporating temperature -50°C						
		0.6	2.4	4.6	6	9	15	
ICM20-A	DN20	0.6	23.8	31.3	39.8	48	51.8	53
ICM20-B	DN20	2.4	131	172	220	269	291	300
ICM20-C	DN20	4.6	205	269	346	427	465	480
ICM25-A	DN25	6	320	418	540	663	720	747
ICM32-A	DN32	9	470	615	789	970	1055	1090
ICM40-A	DN40	15	835	1095	1410	1740	1900	1970
ICM50-A	DN50	23	1435	1880	2430	3000	3270	3400

Expansion

Capacities for nominal conditions, Q_n (TR)

R 22

Type		Pressure drop across valve Δp psi						
		15	30	60	120	180	240	
Evaporating temperature 60°F								
ICM20-A	DN20	0.7	5.6	7.7	10.3	13.1	14.5	15.2
ICM20-B	DN20	2.8	32.5	44.6	59.5	75.5	83.6	87.5
ICM20-C	DN20	5.3	54	73.5	97.5	123	136	142
ICM25-A	DN25	7	83.2	114	151	190	210	220
ICM32-A	DN32	10	120	164	218	275	305	320
ICM40-A	DN40	17	223	303	400	505	560	585
ICM50-A	DN50	27	388	528	695	878	970	1015

		Pressure drop across valve Δp psi					
		15	30	60	120	180	240
Evaporating temperature 40°F							
		6	8.2	10.8	13.6	15	15.6
		34.5	47	62	77.8	85.5	89.5
		57	77	101	126	139	145
		88	119	156	196	216	226
		127	172	226	283	313	327
		236	317	415	517	570	596
		410	550	720	895	990	1035

		Evaporating temperature 20°F						
		0.7	2.8	5.3	7	10	17	
ICM20-A	DN20	0.7	6.3	8.5	11.2	13.9	15.2	15.9
ICM20-B	DN20	2.8	36	48.7	63.6	79	87	90.6
ICM20-C	DN20	5.3	59.5	79.5	103	128	140	146
ICM25-A	DN25	7	92	123	160	198	218	227
ICM32-A	DN32	10	133	178	232	289	317	329
ICM40-A	DN40	17	245	326	423	525	575	600
ICM50-A	DN50	27	427	565	730	905	995	1038

		Evaporating temperature 0°F					
		6.5	8.7	11.4	14.1	15.3	15.9
		37.3	49.8	64.5	80	87	90.2
		60.7	80.5	104	128	140	146
		94	125	161	199	217	226
		136	181	234	289	316	329
		250	330	424	524	575	599
		435	570	730	905	993	1035

		Evaporating temperature -20°F						
		0.7	2.8	5.3	7	10	17	
ICM20-A	DN20	0.7	6.7	8.9	11.5	14.1	15.2	15.7
ICM20-B	DN20	2.8	37.9	50.3	64.5	79.2	86.2	89.1
ICM20-C	DN20	5.3	61.3	80.1	103	127	138	144
ICM25-A	DN25	7	95	125	160	197	215	223
ICM32-A	DN32	10	138	182	233	287	314	325
ICM40-A	DN40	17	251	329	421	518	567	590
ICM50-A	DN50	27	435	565	725	895	980	1020

		Evaporating temperature -40°F					
		6.8	9	11.5	13.9	15	15.4
		38.1	50.2	64	78.5	85	87.6
		60.5	79	101	125	136	140
		94	123	157	193	211	218
		138	180	231	283	307	318
		248	323	413	510	555	575
		428	555	710	875	960	995

		Evaporating temperature -60°F						
		0.7	2.8	5.3	7	10	17	
ICM20-A	DN20	0.7	6.9	9	11.4	13.7	14.7	15
ICM20-B	DN20	2.8	37.7	49.5	63	76.8	83	85
ICM20-C	DN20	5.3	59	77	99	122	132	136
ICM25-A	DN25	7	92	120	154	189	205	212
ICM32-A	DN32	10	135	177	227	276	300	309
ICM40-A	DN40	17	240	314	403	498	540	560
ICM50-A	DN50	27	412	540	695	855	935	965

ICM 20 / ICAD 600

Ordering from the parts programme

Example (select from table I, II and III)

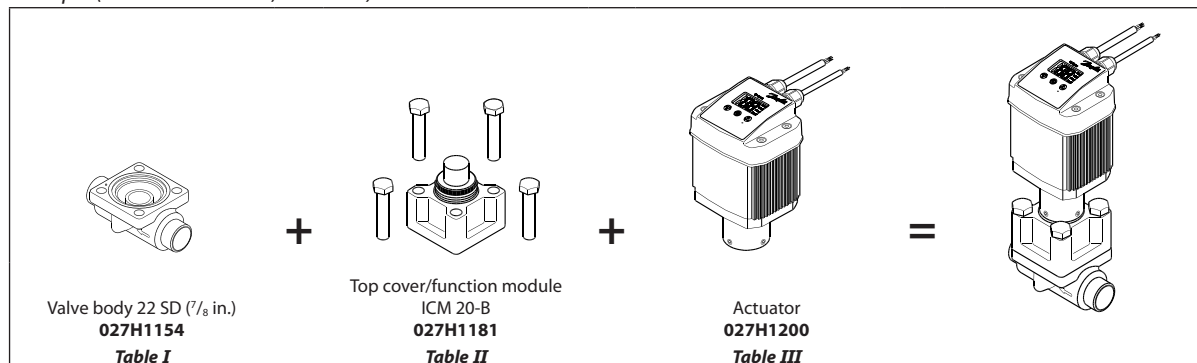

ICV 20 valve body w/different connections **Table I**

20 D (3/4 in.)	25 D (1 in.)	20 A (3/4 in.)	20 SOC (3/4 in.)
027H1145	027H1163	027H1148	027H1151
16 SA (5/8 in.)	22 SA (7/8 in.)	16 SD (5/8 in.)	22 SD (7/8 in.)
027H1129	027H1160	027H1132	027H1154
20 FPT (3/4 in.)		25 A (1 in.)	
027H1157		027H1166	

ICM 20 function module / top cover **Table II**

Description	Code Number
ICM 20-A	027H1180 *)
ICM 20-B	027H1181 *)
ICM 20-C	027H1182 *)

*) Including gasket, bolts and O-rings

ICAD 600 actuator **Table III**

Description	Code Number
ICAD 600	027H1200

D = Butt-weld DIN ; A = Butt-weld ANSI ; J = Butt-weld JIS ; SOC = Socket weld ANSI ; SD = Solder DIN ; SA = Solder ANSI ; FPT = Female Pipe Thread

Ordering complete factory assembled valve without actuator

(body, function module/top cover)

Table A

	Available connections								
	20 D (3/4 in.)	25 D (1 in.)	20 A (3/4 in.)	20 SOC (3/4 in.)	16 SA (5/8 in.)	22 SA (7/8 in.)	16 SD (5/8 in.)	22 SD (7/8 in.)	20 FPT (3/4 in.)
ICM 20-A	027H1030	027H1020	027H1035	027H1040		027H1050		027H1045	
ICM 20-B	027H1031	027H1021	027H1036	027H1041		027H1051		027H1046	
ICM 20-C	027H1032	027H1022				027H1052		027H1047	
	25 A (1 in.)								
ICM 20-A									
ICM 20-B									
ICM 20-C	027H1025								

Select from parts programme

ICAD-UPS for ICM 20-125



Multi-function tool for ICM 20-32



Spare parts and accessories

Spare parts

Spare Parts	Code Number
ICM 20 Service kit	027H1190

Accessories

Accessories	Code Number
ICV 20 top cover blind	027H1174 *)

*) Including bolts and gaskets

ICM 25 / ICAD 600

Ordering from the parts programme

Example (select from table I, II and III)

Valve body 32 D (1 1/4 in.)
027H2129
Table I

Function module/top cover
ICM 25-B
027H2181
Table II

Actuator
ICAD 600
027H1200
Table III

ICV 25 valve body w/different connections *Table I*

20 D (3/4 in.)	25 D (1 in.)	32 D (1 1/4 in.)	40 D (1 1/2 in.)
027H2128	027H2120	027H2129	027H2135
35 SD (1 1/8 in. SA)	28 SA (1 1/8 in.)	22 SA (7/8 in.)	28 SD (1 1/8 in.)
027H2134	027H2126	027H2125	027H2124
22 SD (7/8 in.)	20 A (3/4 in.)	25 A (1 in.)	32 A (1 1/4 in.)
027H2123	027H2131	027H2121	027H2130
20 SOC (3/4 in.)	25 SOC (1 in.)	20 FPT (3/4 in.)	25 FPT (1 in.)
027H2132	027H2122	027H2133	027H2127

ICM 25 function module / top cover *Table II*

Description	Code Number
ICM 25-A	027H2180 *)
ICM 25-B	027H2181 *)

ICAD 600 actuator *Table III*

Description	Code Number
ICAD 600	027H1200

*) Including gasket and O-rings

D = Butt-weld DIN ; A = Butt-weld ANSI ; J = Butt-weld JIS ; SOC = Socket weld ANSI ; SD = Solder DIN ; SA = Solder ANSI ; FPT = Female Pipe Thread

Ordering complete factory assembled valve without actuator (body, function module/top cover) *Table A*

	Available connections							
	20 D (3/4 in.)	25 D (1 in.)	32 D (1 1/4 in.)	40 D (1 1/2 in.)	35 SD (1 1/8 in. SA)	28 SA (1 1/8 in.)	22 SA (7/8 in.)	28 SD (1 1/8 in.)
ICM 25-A		027H2000		027H2016	027H2014	027H2012	027H2010	027H2008
ICM 25-B		027H2001			027H2015	027H2013	027H2011	027H2009
	22 SD (7/8 in.)	20 A (3/4 in.)	25 A (1 in.)	32 A (1 1/4 in.)	20 SOC (3/4 in.)	25 SOC (1 in.)	20 FPT (3/4 in.)	25 FPT (1 in.)
ICM 25-A	027H2006		027H2002			027H2004		
ICM 25-B	027H2007		027H2003			027H2005		

Select from parts programme

ICAD-UPS for ICM 20-125

027H0182

Multi-function tool for ICM 20-32

027H0180

Spare parts and accessories

Spare parts

Spare Parts	Code Number
ICM 25 Service kit	027H2220

Accessories

Accessories	Code Number
ICV 25 top cover blind	027H2174 *)

*) Including bolts and gaskets

ICM 32 / ICAD 600

Ordering from the parts programme

Example (select from table I, II and III)

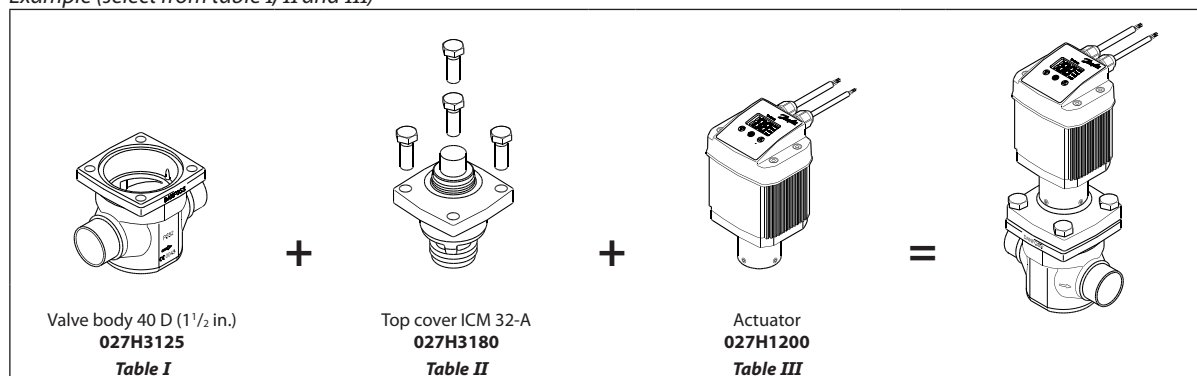

ICV 32 valve body w/different connections *Table I*



32 D (1 1/4 in.)	40 D (1 1/2 in.)	42 SA (1 5/8 in.)	42 SD (1 5/8 in.)
027H3120	027H3125	027H3127	027H3128
35 SD (1 5/8 in. SA)	32 A (1 1/4 in.)	32 SOC (1 1/4 in.)	40 A (1 1/2 in.)
027H3123	027H3121	027H3122	027H3126

ICM 32 function module / top cover *Table II*

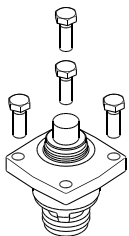

Description	Code Number
ICM 32-A	027H3180 *
ICM 32-B	027H3181 *

*) Including gasket and O-rings

ICAD 600 actuator *Table III*

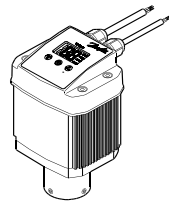

Description	Code Number
ICAD 600	027H1200

D = Butt-weld DIN ; A = Butt-weld ANSI ; J = Butt-weld JIS ; SOC = Socket weld ANSI ; SD = Solder DIN ; SA = Solder ANSI ; FPT = Female Pipe Thread

Ordering complete factory assembled valve without actuator (body, function module/top cover)

Table A

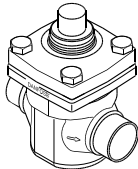

	Available connections							
	32 D (1 1/4 in.)	40 D (1 1/2 in.)	42 SA (1 5/8 in.)	42 SD (1 5/8 in.)	35 SD (1 5/8 in. SA)	32 A (1 1/4 in.)	32 SOC (1 1/4 in.)	40 A (1 1/2 in.)
ICM 32-A	027H3000	027H3012	027H3008		027H3006	027H3002	027H3004	
ICM 32-B	027H3001		027H3009		027H3007	027H3003	027H3005	

Select from parts programme

Spare parts and accessories

Spare parts

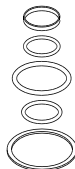

Spare Parts	Code Number
ICM 32 Service kit	027H3220

Accessories

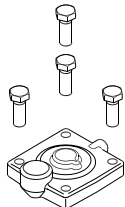

Accessories	Code Number
ICV 32 top cover blind	027H3174 *

*) Including bolts and gaskets

ICAD-UPS for ICM 20-125



Multi-function tool for ICM 20-32



ICM 40 / ICAD 900

Ordering from the parts programme

Example (select from table I, II and III)

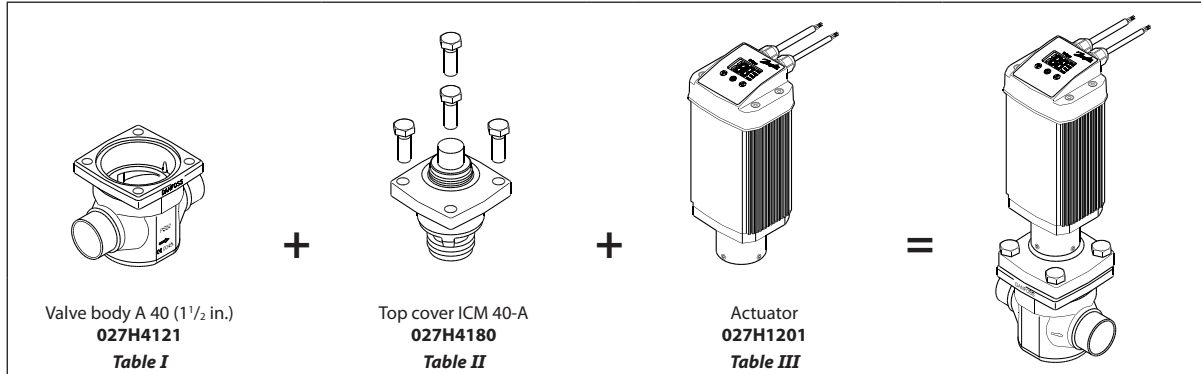

ICV 40 valve body w/different connections Table I

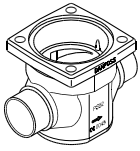

40 D (1 1/2 in.)	50 D (2 in.)	42 SA (1 5/8 in.)	42 SD (1 5/8 in.)
027H4120	027H4126	027H4124	027H4123
40 A (1 1/2 in.)	40 SOC (1 1/2 in.)	50 A (2 in.)	
027H4121	027H4122	027H4127	

ICM 40 function module / top cover Table II

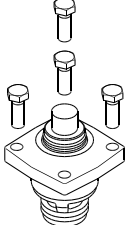

Description	Code Number
ICM 40-A	027H4180 *)
ICM 40-B	027H4181 *)

*) Including gasket and O-rings

ICAD 900 actuator Table III

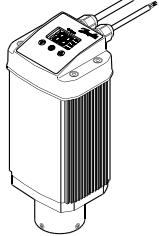

Description	Code Number
ICAD 900	027H1201

D = Butt-weld DIN ; A = Butt-weld ANSI ; J = Butt-weld JIS ; SOC = Socket weld ANSI ; SD = Solder DIN ; SA = Solder ANSI ; FPT = Female Pipe Thread

Ordering complete factory assembled valve without actuator (body, function module/top cover)

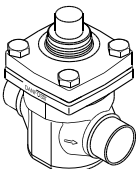

	Available connections						
	40 D (1 1/2 in.)	50 D (2 in.)	42 SA (1 5/8 in.)	42 SD (1 5/8 in.)	40 A (1 1/2 in.)	40 SOC (1 1/2 in.)	50 A (2 in.)
ICM 40-A	027H4000	027H4010	027H4006	027H4008	027H4002	027H4004	
ICM 40-B	027H4001		027H4007	027H4009	027H4003	027H4005	

Select from parts programme

Spare parts and accessories

Spare parts

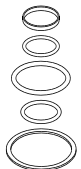

Spare Parts	Code Number
ICM 40 Service kit	027H4220

Accessories

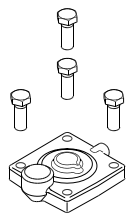

Accessories	Code Number
ICV 40 top cover blind	027H4174 *)

*) Including bolts and gaskets

ICAD-UPS for ICM 20-125



Multi-function tool for ICM 40-65

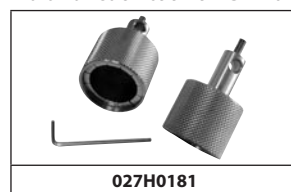

ICM 50 / ICAD 900

Ordering from the parts programme

Example (select from table I, II and III)

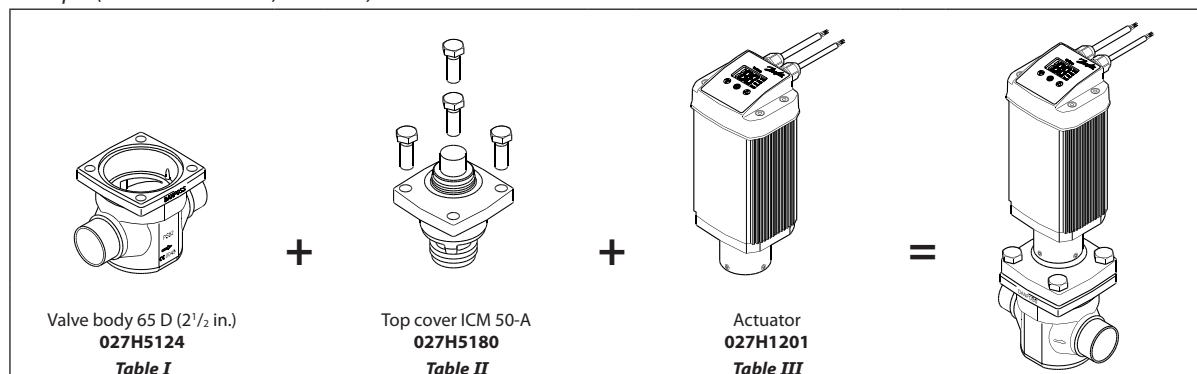

ICV 50 valve body w/different connections **Table I**

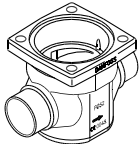

50 D (2 in.)	65 D (2 1/2 in.)	54 SD (2 1/8 in. SA)	50 A (2 in.)
027H5120	027H5124	027H5123	027H5121
50 SOC (2 in.)	65 A (2 1/2 in.)		
027H5122	027H5125		

ICM 50 function module / top cover **Table II**

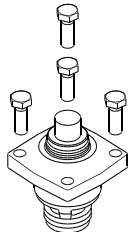

Description	Code Number
ICM 50-A	027H5180 *)
ICM 50-B	027H5181 *)

*) Including gasket and O-rings

ICAD 900 actuator **Table III**

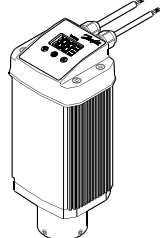

Description	Code Number
ICAD 900	027H1201

D = Butt-weld DIN ; A = Butt-weld ANSI ; J = Butt-weld JIS ; SOC = Socket weld ANSI ; SD = Solder DIN ; SA = Solder ANSI ; FPT = Female Pipe Thread

Ordering complete factory assembled valve without actuator (body, function module/top cover)

Table A

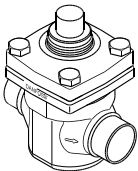

	Available connections					
	50 D (2 in.)	65 D (2 1/2 in.)	54 SD (2 1/8 in. SA)	50 A (2 in.)	50 SOC (2 in.)	65 A (2 1/2 in.)
ICM 50-A	027H5000	027H5008	027H5006	027H5002	027H5004	
ICM 50-B	027H5001		027H5007	027H5003	027H5005	

Select from parts programme

Spare parts and accessories

Spare parts

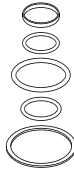

Spare Parts	Code Number
ICM 50 Service kit	027H5220

Accessories

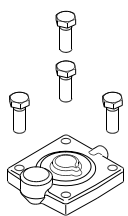

Accessories	Code Number
ICV 50 top cover blind	027H5174 *)

*) Including bolts and gaskets

ICAD-UPS for ICM 20-125



Multi-function tool for ICM 40-65



ICM 65 / ICAD 900

Ordering from the parts programme

Example (select from table I, II and III)

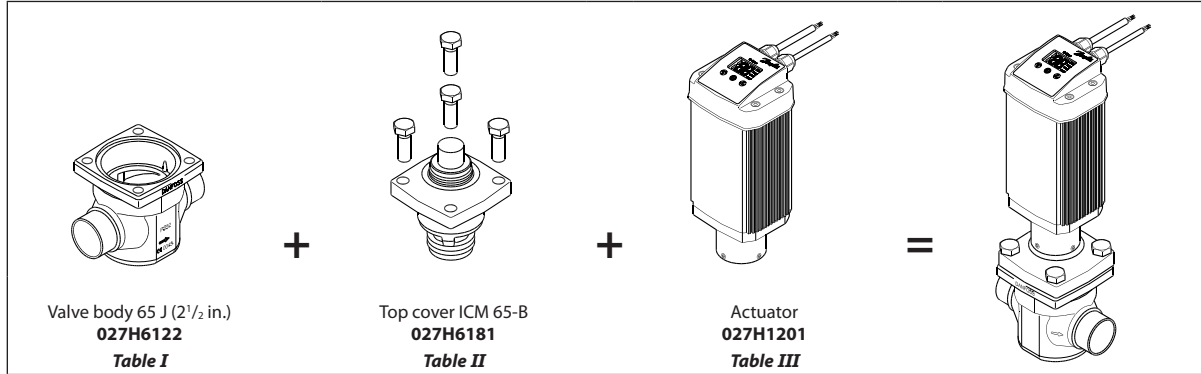

ICV 65 valve body w/different connections *Table I*

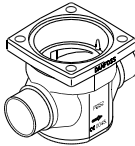

65 D (2 1/2 in.)	65 A (2 1/2 in.)	65 J (2 1/2 in.)	80 D (3 in.)
027H6120	027H6121	027H6122	027H6126
80 A (3 in.)	67 SA (2 5/8 in.)	76 SD (3 in.)	65 SOC (2 1/2 in.)
027H6127	027H6125	027H6124	027H6123

ICM 65 Function module / top cover *Table II*

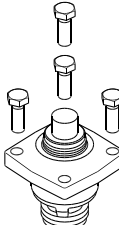

Description	Code Number
ICM 65-B	027H6181 *)

*) Including gasket and O-rings

ICAD 900 actuator *Table III*

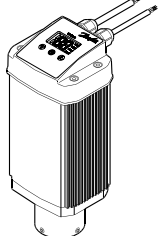

Description	Code Number
ICAD 900	027H1201

D = Butt-weld DIN ; A = Butt-weld ANSI ; J = Butt-weld JIS ; SOC = Socket weld ANSI ; SD = Solder DIN ; SA = Solder ANSI ; FPT = Female Pipe Thread

Ordering complete factory assembled valve without actuator (body, function module/top cover)

Table A

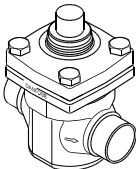

	Available connections							
	65 D (2 1/2 in.)	65 A (2 1/2 in.)	65 J (2 1/2 in.)	80 D (3 in.)	80 A (3 in.)	67 SA (2 5/8 in.)	76 SD (3 in.)	65 SOC (2 1/2 in.)
ICM 65-B	027H6001	027H6003				027H6007	027H6009	027H6005

Select from parts programme

Spare parts and accessories

Spare parts

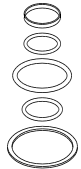

Spare Parts	Code Number
ICM 65 Service kit	027H6220

Accessories

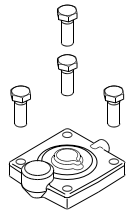

Accessories	Code Number
ICV 65 top cover blind	027H6174 *)

*) Including bolts and gaskets

ICAD-UPS for ICM 20-125



Multi-function tool for ICM 40-65

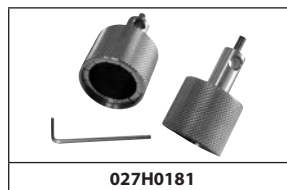

ICM 20 / ICAD 600

Dimensions

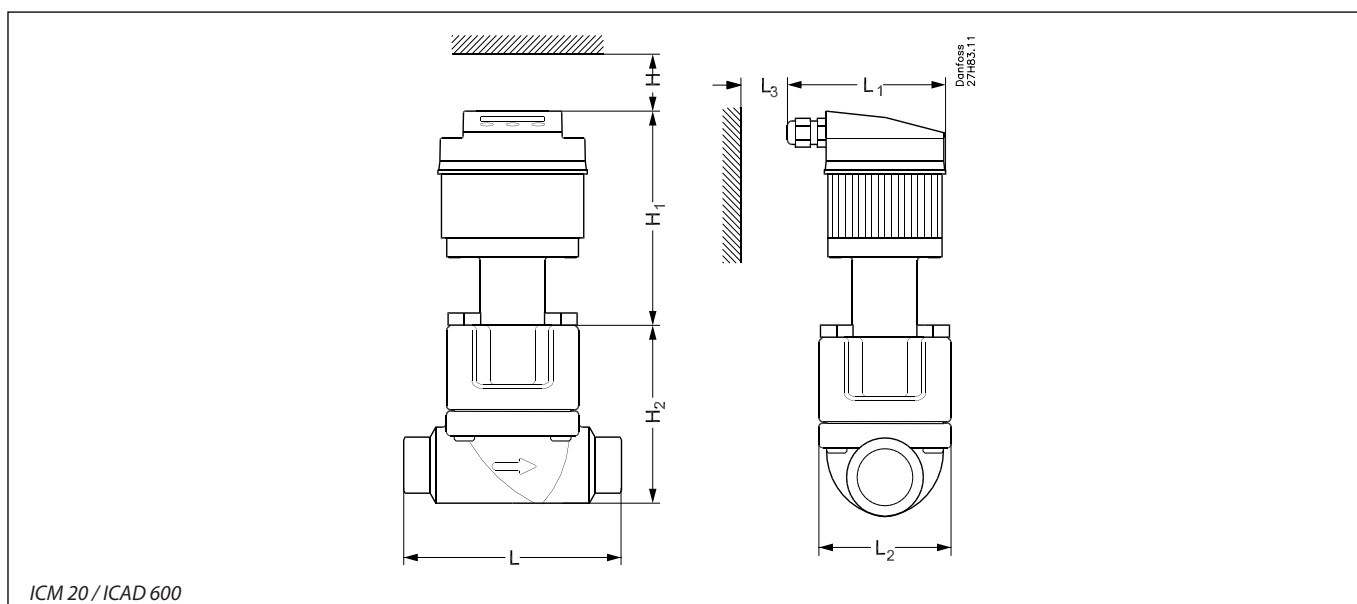

Connection		H	H ₁	H ₂	L	L ₁	L ₂	Weight ICM incl. ICAD
20 D (3/4 in.)	mm	40	146	85	107	87	65	3 kg
	in.	1.58	5.75	3.35	4.21	3.43	2.56	6.6 lb.
25 D (1 in.)	mm	40	146	85	107	87	65	3 kg
	in.	1.58	5.75	3.35	4.21	3.43	2.56	6.6 lb.
25 A (1 in.)	mm	40	146	85	107	87	65	3 kg
	in.	1.58	5.75	3.35	4.21	3.43	2.56	6.6 lb.
20 A (3/4 in.)	mm	40	146	85	107	87	65	3 kg
	in.	1.58	5.75	3.35	4.21	3.43	2.56	6.6 lb.
20 SOC (3/4 in.)	mm	40	146	85	107	87	65	3 kg
	in.	1.58	5.75	3.35	4.21	3.43	2.56	6.6 lb.
16 SD (5/8 in.)	mm	40	146	85	107	87	65	3 kg
	in.	1.58	5.75	3.35	4.21	3.43	2.56	6.6 lb.
22 SD (7/8 in.)	mm	40	146	85	107	87	65	3 kg
	in.	1.58	5.75	3.35	4.21	3.43	2.56	6.6 lb.
16 SA (5/8 in.)	mm	40	146	85	107	87	65	3 kg
	in.	1.58	5.75	3.35	4.21	3.43	2.56	6.6 lb.
22 SA (7/8 in.)	mm	40	146	85	107	87	65	3 kg
	in.	1.58	5.75	3.35	4.21	3.43	2.56	6.6 lb.
20 FPT (3/4 in.)	mm	40	146	85	107	87	65	3 kg
	in.	1.58	5.75	3.35	4.21	3.43	2.56	6.6 lb.

D = Butt-weld DIN ; A = Butt-weld ANSI ; J = Butt-weld JIS ; SOC = Socket weld ANSI ; SD = Solder DIN ; SA = Solder ANSI ; FPT = Female Pipe Thread

ICM 25 / ICAD 600

Dimensions (continued)

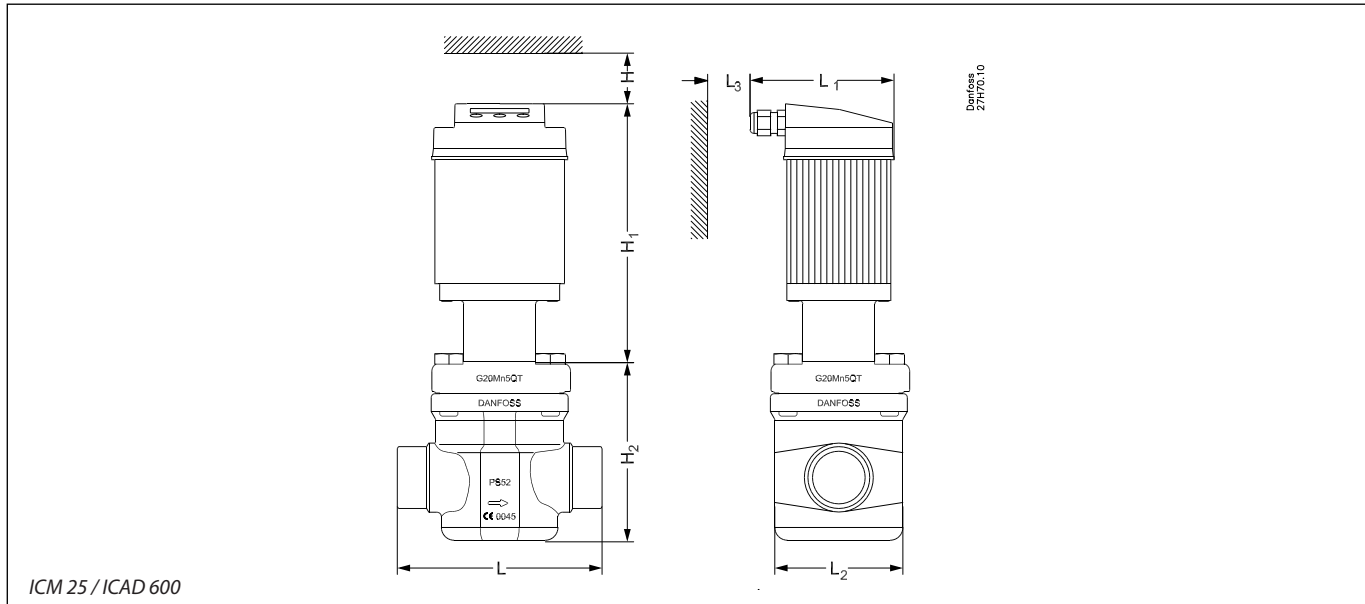

Connection	H	H ₁	H ₂	L	L ₁	L ₂	Weight ICM incl. ICAD
20 D (3/4 in.)	mm	40	153	99	135	87	4.1 kg
	in.	1.58	6.02	3.90	5.31	3.43	8.8 lb.
25 D (1 in.)	mm	40	153	99	135	87	4.1 kg
	in.	1.58	6.02	3.90	5.31	3.43	8.8 lb.
32 D (1 1/4 in.)	mm	40	153	99	135	87	4.1 kg
	in.	1.58	6.02	3.90	5.31	3.43	8.8 lb.
40 D (1 1/2 in.)	mm	40	153	99	135	87	4.1 kg
	in.	1.58	6.02	3.90	5.31	3.43	8.8 lb.
20 A (3/4 in.)	mm	40	153	99	135	87	4.1 kg
	in.	1.58	6.02	3.90	5.31	3.43	8.8 lb.
25 A (1 in.)	mm	40	153	99	135	87	4.1 kg
	in.	1.58	6.02	3.90	5.31	3.43	8.8 lb.
32 A (1 1/4 in.)	mm	40	153	99	135	87	4.1 kg
	in.	1.58	6.02	3.90	5.31	3.43	8.8 lb.
20 SOC (3/4 in.)	mm	40	153	99	135	87	4.1 kg
	in.	1.58	6.02	3.90	5.31	3.43	8.8 lb.
25 SOC (1 in.)	mm	40	153	99	148	87	4.1 kg
	in.	1.58	6.02	3.90	5.83	3.43	8.8 lb.
22 SD (7/8 in.)	mm	40	153	99	135	87	4.1 kg
	in.	1.58	6.02	3.90	5.31	3.43	8.8 lb.
28 SD (1 1/8 in.)	mm	40	153	99	147	87	4.1 kg
	in.	1.58	6.02	3.90	5.79	3.43	8.8 lb.
22 SA (7/8 in.)	mm	40	153	99	135	87	4.1 kg
	in.	1.58	6.02	3.90	5.31	3.43	8.8 lb.
28 SA (1 1/8 in.)	mm	40	153	99	147	87	4.1 kg
	in.	1.58	6.02	3.90	5.79	3.43	8.8 lb.
35 SD (1 3/8 in. SA)	mm	40	153	99	147	87	4.1 kg
	in.	1.58	6.02	3.90	5.79	3.43	8.8 lb.
20 FPT (3/4 in.)	mm	40	153	99	135	87	4.1 kg
	in.	1.58	6.02	3.90	5.31	3.43	8.8 lb.
25 FPT (1 in.)	mm	40	153	99	135	87	4.1 kg
	in.	1.58	6.02	3.90	5.31	3.43	8.8 lb.

D = Butt-weld DIN ; A = Butt-weld ANSI ; J = Butt-weld JIS ; SOC = Socket weld ANSI ; SD = Solder DIN ; SA = Solder ANSI ; FPT = Female Pipe Thread

ICM 32 / ICAD 600

Dimensions (continued)

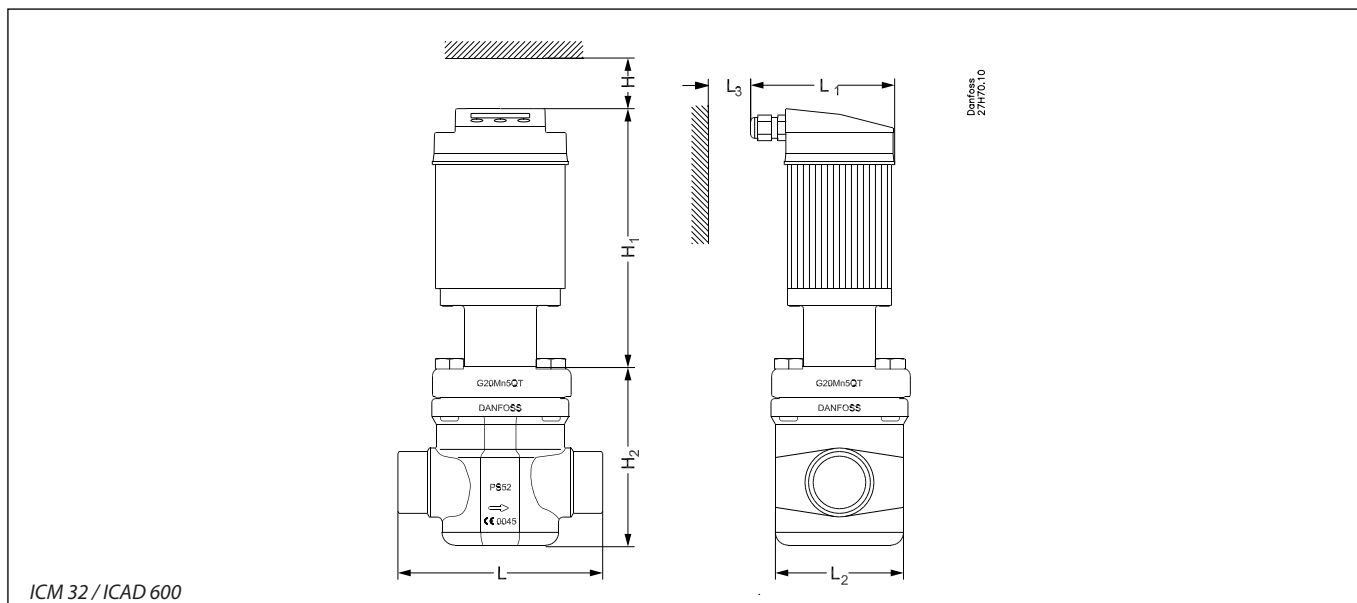

Connection		H	H ₁	H ₂	L	L ₁	L ₂	Weight ICM incl. ICAD
32 D (1 ¹ / ₄ in.)	mm	40	146	117	145	87	102	5.8 kg
	in.	1.58	5.75	4.61	5.71	3.43	4.02	11.0 lb.
40 D (1 ¹ / ₂ in.)	mm	40	146	117	145	87	102	5.8 kg
	in.	1.58	5.75	4.61	5.71	3.43	4.02	11.0 lb.
32 A (1 ¹ / ₄ in.)	mm	40	146	117	145	87	102	5.8 kg
	in.	1.58	5.75	4.61	5.71	3.43	4.02	11.0 lb.
40 A (1 ¹ / ₂ in.)	mm	40	146	117	145	87	102	5.8 kg
	in.	1.58	5.75	4.61	5.71	3.43	4.02	11.0 lb.
32 SOC (1 ¹ / ₄ in.)	mm	40	146	117	147	87	102	5.8 kg
	in.	1.58	5.75	4.61	5.79	3.43	4.02	11.0 lb.
35 SD (1 ³ / ₈ in. SA)	mm	40	146	117	148	87	102	5.8 kg
	in.	1.58	5.75	4.61	5.83	3.43	4.02	11.0 lb.
42 SD (1 ⁵ / ₈ in.)	mm	40	146	117	148	87	102	5.8 kg
	in.	1.58	5.75	4.61	5.83	3.43	4.02	11.0 lb.
42 SA (1 ⁵ / ₈ in.)	mm	40	146	117	148	87	102	5.8 kg
	in.	1.58	5.75	4.61	5.83	3.43	4.02	11.0 lb.

D = Butt-weld DIN ; A = Butt-weld ANSI ; J = Butt-weld JIS ; SOC = Socket weld ANSI ; SD = Solder DIN ; SA = Solder ANSI ; FPT = Female Pipe Thread

ICM 40 / ICAD 900

Dimensions (continued)

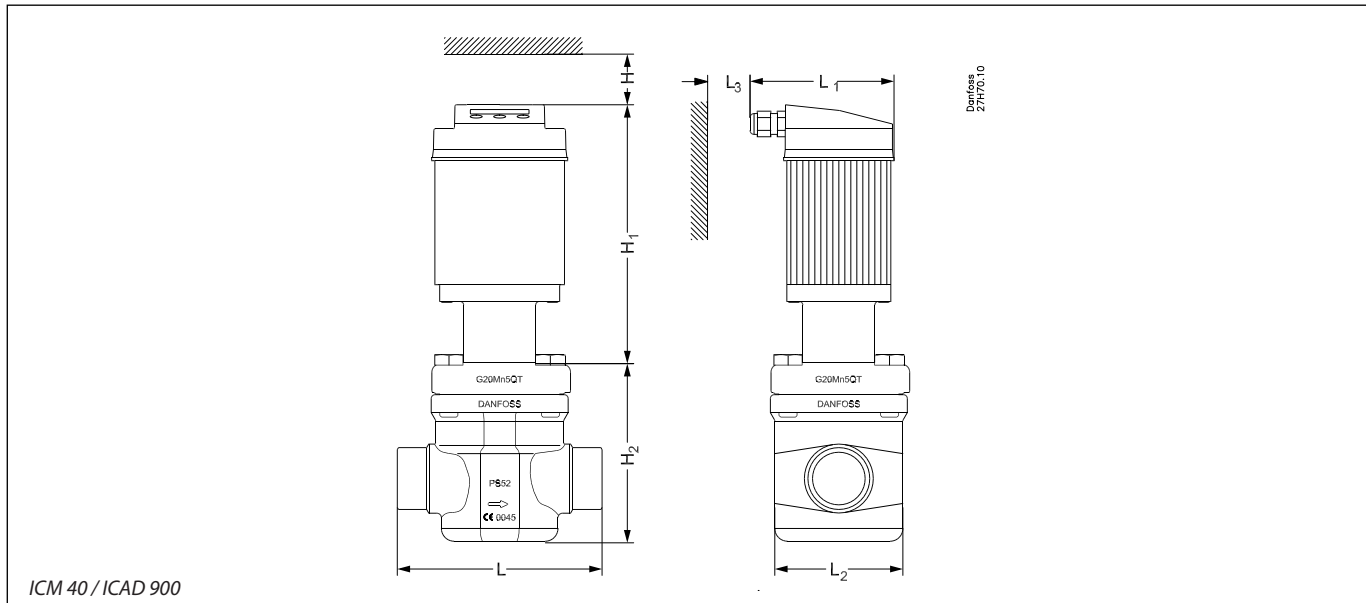

Connection	H	H ₁	H ₂	L	L ₁	L ₂	Weight ICM incl. ICAD
40 D (1½ in.)	mm	45	184	131	160	87	7.8 kg
	in.	1.77	7.24	5.16	6.30	3.43	17.2 lb
50 D (2 in.)	mm	45	184	131	180	87	7.8 kg
	in.	1.77	7.24	5.16	7.09	3.43	17.2 lb
40 A (1½ in.)	mm	45	184	131	160	87	7.8 kg
	in.	1.77	7.24	5.16	6.30	3.43	17.2 lb
50 A (2 in.)	mm	45	184	131	180	87	7.8 kg
	in.	1.77	7.24	5.16	7.09	3.43	17.2 lb
40 SOC (1½ in.)	mm	45	184	131	180	87	7.8 kg
	in.	1.77	7.24	5.16	7.09	3.43	17.2 lb
42 SD (1⅝ in.)	mm	45	184	131	180	87	7.8 kg
	in.	1.77	7.24	5.16	7.09	3.43	17.2 lb
42 SA (1⅝ in.)	mm	45	184	131	180	87	7.8 kg
	in.	1.77	7.24	5.16	7.09	3.43	17.2 lb

D = Butt-weld DIN ; A = Butt-weld ANSI ; J = Butt-weld JIS ; SOC = Socket weld ANSI ; SD = Solder DIN ; SA = Solder ANSI ; FPT = Female Pipe Thread

ICM 50 / ICAD 900

Dimensions (continued)

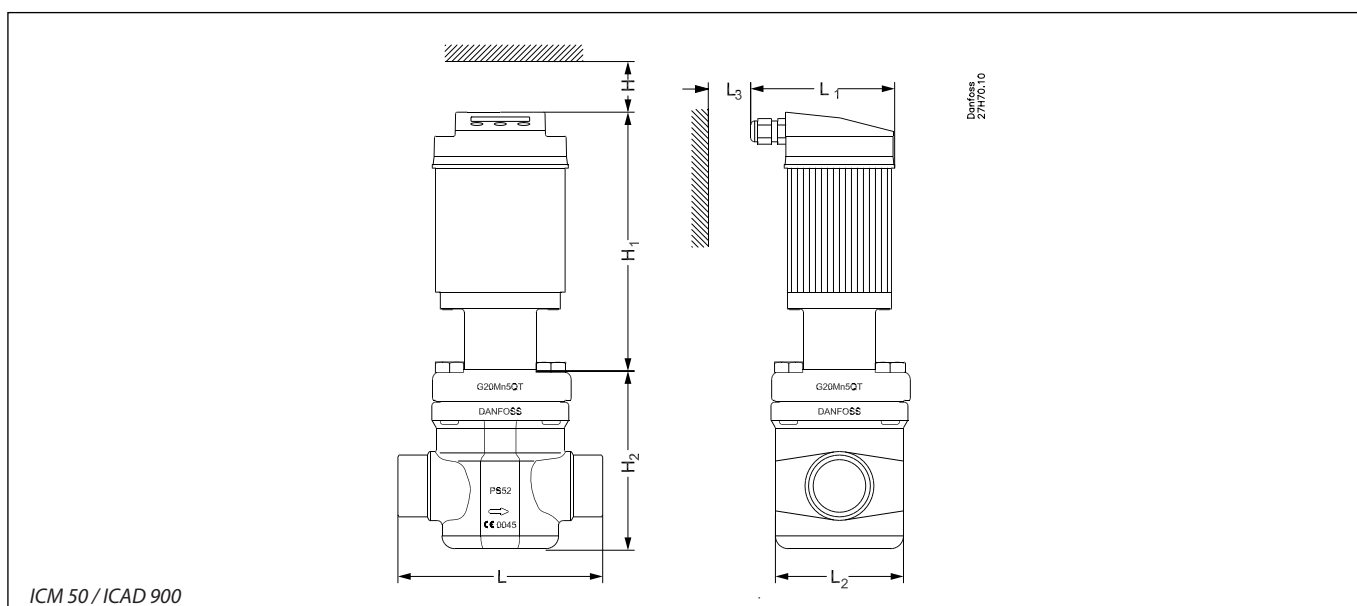

Connection		H	H ₁	H ₂	L	L ₁	L ₂	Weight ICM incl. ICAD
50 D (2 in.)	mm	45	176	159	200	87	125	11.1
	in.	1.77	6.93	6.26	7.87	3.43	4.92	24.4
65 D (2½ in.)	mm	45	176	159	210	87	125	11.1
	in.	1.77	6.93	6.26	8.27	3.43	4.92	24.4
50 A (2 in.)	mm	45	176	159	200	87	125	11.1
	in.	1.77	6.93	6.26	7.87	3.43	4.92	24.4
65 A (2½ in.)	mm	45	176	159	210	87	125	11.1
	in.	1.77	6.93	6.26	8.27	3.43	4.92	24.4
50 SOC (2 in.)	mm	45	176	159	216	87	125	11.1
	in.	1.77	6.93	6.26	8.50	3.43	4.92	24.4
54 SD (2⅞ in. SA)	mm	45	176	159	216	87	125	11.1
	in.	1.77	6.93	6.26	8.50	3.43	4.92	24.4

D = Butt-weld DIN ; A = Butt-weld ANSI ; J = Butt-weld JIS ; SOC = Socket weld ANSI ; SD = Solder DIN ; SA = Solder ANSI ; FPT = Female Pipe Thread

ICM 65 / ICAD 900

Dimensions (continued)

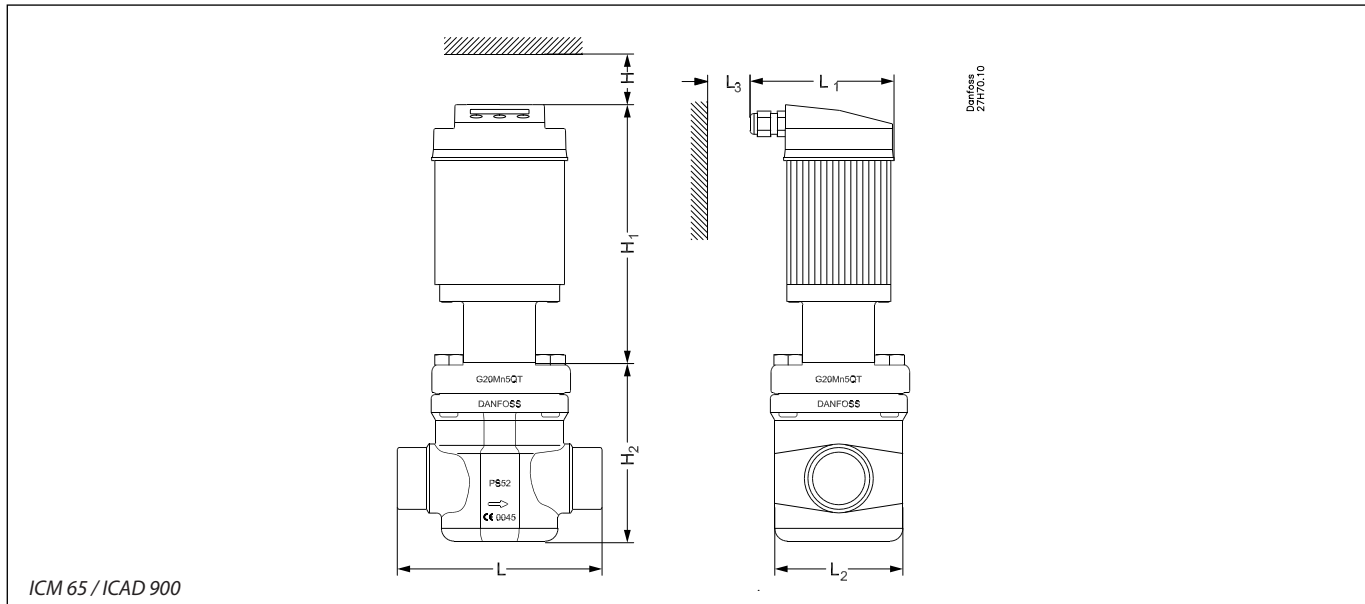

Connection	H	H ₁	H ₂	L	L ₁	L ₂	Weight ICM incl. ICAD	
65 D (2 1/2 in.)	mm	45	176	188	230	87	139	16.6 kg
	in.	1.77	6.93	7.40	9.06	3.43	5.47	36.5 lb
80 D (3 in.)	mm	45	176	188	245	87	139	16.6 kg
	in.	1.77	6.93	7.40	9.65	3.43	5.47	36.5 lb
65 A (2 1/2 in.)	mm	45	176	188	230	87	139	16.6 kg
	in.	1.77	6.93	7.40	9.06	3.43	5.47	36.5 lb
80 A (3 in.)	mm	45	176	188	245	87	139	16.6 kg
	in.	1.77	6.93	7.40	9.65	3.43	5.47	36.5 lb
65 J (2 1/2 in.)	mm	45	176	188	230	87	139	16.6 kg
	in.	1.77	6.93	7.40	9.06	3.43	5.47	36.5 lb
65 SOC (2 1/2 in.)	mm	45	176	188	230	87	139	16.6 kg
	in.	1.77	6.93	7.40	9.06	3.43	5.47	36.5 lb
76 SD (3 in.)	mm	45	176	188	245	87	139	16.6 kg
	in.	1.77	6.93	7.40	9.65	3.43	5.47	36.5 lb
67 SA (2 5/8 in.)	mm	45	176	188	245	87	139	16.6 kg
	in.	1.77	6.93	7.40	9.65	3.43	5.47	36.5 lb

D = Butt-weld DIN ; A = Butt-weld ANSI ; J = Butt-weld JIS ; SOC = Socket weld ANSI ; SD = Solder DIN ; SA = Solder ANSI ; FPT = Female Pipe Thread

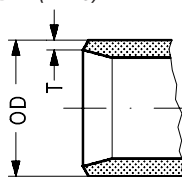
Connections
D: Butt-weld DIN (2448)

Size mm	Size in.	OD mm	T mm	OD in.	T in.		
20	($\frac{3}{4}$)	26.9	2.3	1.059	0.091		
25	(1)	33.7	2.6	1.327	0.103		
32	($1\frac{1}{4}$)	42.4	2.6	1.669	0.102		
40	($1\frac{1}{2}$)	48.3	2.6	1.902	0.103		
50	(2)	60.3	2.9	2.37	0.11		
65	($2\frac{1}{2}$)	76.1	2.9	3	0.11		
80	(3)	88.9	3.2	3.50	0.13		

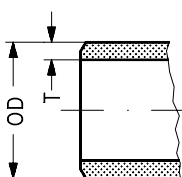
A: Butt-weld ANSI (B 36.10)

Size mm	Size in.	OD mm	T mm	OD in.	T in.	Schedule	
(20)	$\frac{3}{4}$	26.9	4.0	1.059	0.158	80	
(25)	1	33.7	4.6	1.327	0.181	80	
(32)	$1\frac{1}{4}$	42.4	4.9	1.669	0.193	80	
(40)	$1\frac{1}{2}$	48.3	5.1	1.902	0.201	80	
(50)	2	60.3	3.9	2.37	0.15	40	
(65)	$2\frac{1}{2}$	73.0	5.2	2.87	0.20	40	
(80)	3	88.9	5.5	3.50	0.22	40	

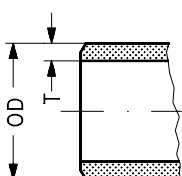
J: Butt-weld JIS

Size mm	Size in.	OD mm	T mm	OD in.	T in.		
(20)	$\frac{3}{4}$	26.9	4.0	1.059	0.158		
(25)	1	33.7	4.6	1.327	0.181		
(32)	$1\frac{1}{4}$	42.4	4.9	1.669	0.193		
(40)	$1\frac{1}{2}$	48.3	5.1	1.902	0.201		
(50)	2	60.3	3.9	2.37	0.15		
(65)	$2\frac{1}{2}$	76.3	5.2	3.0	0.20		
(80)	3	88.9	5.5	3.50	0.22		

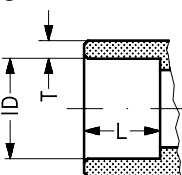
SOC:
Socket welding ANSI (B 16.11)

Size mm	Size in.	ID mm	T mm	ID in.	T in.	L mm	L in.
(20)	$\frac{3}{4}$	27.2	4.6	1.071	0.181	13	0.51
(25)	1	33.9	7.2	1.335	0.284	13	0.51
(32)	$1\frac{1}{4}$	42.7	6.1	1.743	0.240	13	0.51
(40)	$1\frac{1}{2}$	48.8	6.6	1.921	0.260	13	0.51
(50)	2	61.2	6.2	2.41	0.24	16	0.63
(65)	$2\frac{1}{2}$	74	8.8	2.91	0.344	16	0.63

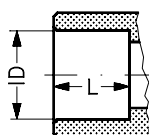
SD: Soldering (DIN 2856)

Size mm	Size in.	ID mm	ID in.	L mm	L in.
16		16.07		15	
22		22.08		16.5	
28		28.08		26	
35		35.07		25	
42		42.07		28	
54		54.09		33	
76		76.1		33	

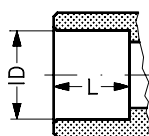
SA: Soldering (ANSI B 16.22)

	Size in.				
	$\frac{5}{8}$		0.625		0.591
	$\frac{7}{8}$		0.875		0.650
	$1\frac{1}{8}$		1.125		1.024
	$1\frac{3}{8}$		1.375		0.984
	$1\frac{5}{8}$		1.625		1.102
	$2\frac{1}{8}$		2.125		1.300
	$2\frac{3}{8}$		2.625		1.300

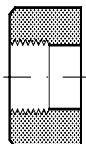
FPT:
Female pipe thread, (ANSI/ASME B 1.20.1)

Size mm	Size in.	Inside pipe thread		
(20)	$\frac{3}{4}$	($\frac{3}{4}$ x 14 NPT)		
(25)	1	(1 x 11.5 NPT)		
(32)	$1\frac{1}{4}$	($1\frac{1}{4}$ x 11.5 NPT)		

General operation

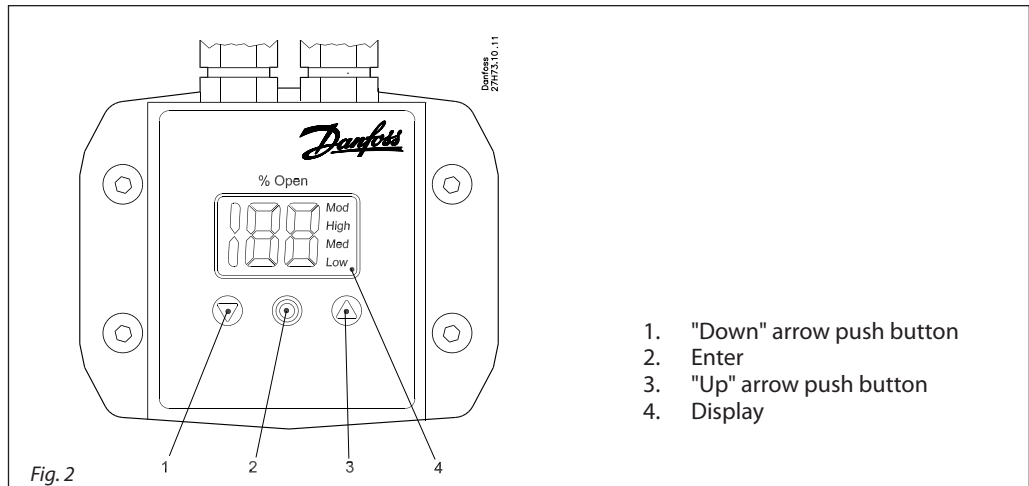

ICAD is equipped with an MMI (Man Machine Interface) from which it is possible to monitor and change the setting of parameters to adapt the ICAD and the corresponding ICM to the actual refrigeration application.

The setting of parameters is managed by means of the integrated ICAD MMI (see fig. 2 and fig. 3) and consists of:

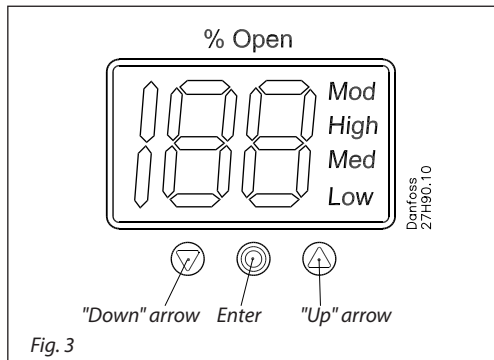

- "Down" arrow push button (fig. 2, pos. 1)
 - Decreases parameter number by 1 at each activation
- "Up" arrow pushbutton (fig. 2, pos. 3)
 - Increases parameter number by 1 at each activation
- Enter push button (fig. 2, pos. 2)
 - Gives access to the **Parameter list** by keeping the push button activated for 2 seconds. A **Parameter list** example is shown below (parameter **i08**, fig. 4).

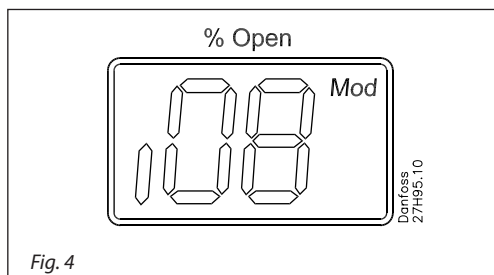

- Gives access to change a value once the **Parameter list** has been accessed.
- Acknowledge and save change of value of a parameter.

- To exit from the **Parameter list** and return to the display of Opening Degree (OD) keep the push button activated for 2 seconds.
- Display (fig. 2, pos. 4)
 - Normally the Opening Degree (OD) 0 - 100 % of the ICM valve is displayed. No activation of push buttons for 20 seconds means that the display will always show OD (see fig. 5).

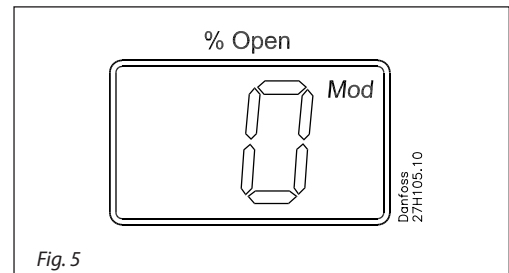

- Displays the parameter.
- Displays the actual value of a parameter.
- Displays the function status by means of text (fig. 2, pos. 4)
 - **Mod** represents that ICAD is positioning the ICM valve according to an analog input signal (Current or Voltage)
 - **Low** represents that ICAD is operating the ICM valve like an ON/OFF solenoid valve with low speed according to a digital input signal.
 - **Med** represents that ICAD is operating the ICM valve like an ON/OFF solenoid valve with medium speed according to a digital input signal.
 - **High** represents that ICAD is operating the ICM valve like an ON/OFF solenoid valve with high speed according to a digital input signal (see fig. 6).

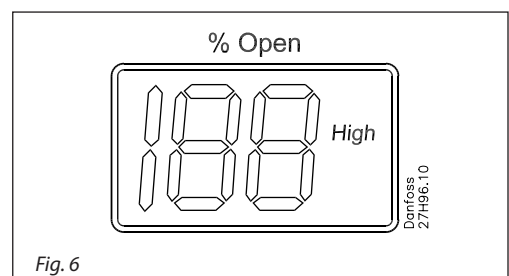

Alarms

ICAD can handle and display different alarms.

Description	ICM alarm text	Comments
No valve type selected	A1	At start-up A1 and CA will be displayed
Controller fault	A2	Internal fault inside electronics
All input error	A3	Not active if j01 = 2 or j02 = 2 When j03 = 1 and AI A > 22 mA When j03 = 2 and AI A > 22 mA or AI A < 2 mA When j03 = 3 and AI A > 12 V When j03 = 4 and AI A > 12 V or AI A < 1 V
Low voltage of fail safe supply	A4	If 5 V d.c. < Fail safe supply < 18 V d.c.
Check Supply to ICAD	A5	If supply voltage < 18 V d.c.

If an alarm has been detected the ICAD display (fig. 2) will alternate between showing Actual alarm and present Opening Degree.

If more than one alarm is active at the same time the alarm with the highest priority will take preference. **A1** has the highest priority, **A5** the lowest.

Any active alarm will activate the Common Digital Alarm output (Normally Open).

All alarms will automatically reset them-selves when they physically disappear.

Old alarms (alarms that have been active, but have physically disappeared again) can be found in parameter **j11**.

Parameter list

Description	Display name	Min.	Max.	Factory setting	Unit	Comments
ICM OD (Opening Degree)	-	0	100	-	%	ICM valve Opening Degree is displayed during normal operation. Running display value (see j01 , j05).
Main Switch	j01	1	2	1	-	Internal main switch 1: Normal operation 2: Manual operation. Valve Opening Degree will be flashing. With the down arrow and the up arrow push buttons the OD can be entered manually.
Mode	j02	1	2	1	-	Operation mode 1: Modulating – ICM positioning according to Analogue Input (see j03) 2: ON/OFF - operating the ICM valve like an ON/OFF solenoid valve controlled via Digital Input. See also j09 .
Analogue Input signal	j03	1	4	2	-	Type of Analogue Input signal from external controller 1: 0 - 20 mA 2: 4 - 20 mA 3: 0 - 10 V 4: 2 - 10 V
Speed at ON/OFF and Modulating Mode	j04	1	100	100	%	Speed can be decreased. Max. speed is 100 % Not active when j01 = 2 If j02 = 2 the display will indicate speed in display. Low , Med and High also means ON/OFF operation. If j04 < = 33, Low is displayed 33 < j04 < = 66, Med is displayed If j04 > = 67 High is displayed
Automatic calibration	j05	0	1	0	-	Not active before j26 has been operated. Always auto reset to 0. CA will flash in the display during calibration, if Enter push button has been activated for two seconds.
Analogue Output signal	j06	0	2	2	-	Type of A0 signal for ICM valve position 0: No signal 1: 0 - 20 mA 2: 4 - 20 mA
Fail safe	j07	1	4	1	-	Define condition at power cut when fail safe is installed. 1: Close valve 2: Open valve 3: Maintain valve position 4: Go to OD given by j12
Digital Input function	j09	1	2	1	-	Define function when DI is ON (short circuited DI terminals) when j02 = 2 1: Open ICM valve (DI = OFF => Close ICM valve) 2: Close ICM valve (DI = OFF => Open ICM valve)
Password	j10	0	199	0	-	Enter number to access password protected parameters: j26
Old Alarms	j11	A1	A99	-	-	Old alarms will be listed with the latest shown first. Alarm list can be reset by means of activating down arrow and up arrow at the same time for 2 seconds.
OD at powercut	j12	0	100	50	-	Only active if j07 = 4 If fail safe supply is connected and powercut occurs ICM will go to entered OD.
ICM configuration	j26	0	6	0	-	NB: Password protected. Password = 11 At first start up A1 will flash in display. Enter valve type 0: No valve selected. Alarm A1 will become active. 1: ICM20 with ICAD 600 2: ICM25 with ICAD 600 3: ICM32 with ICAD 600 4: ICM40 with ICAD 900 5: ICM50 with ICAD 900 6: ICM65 with ICAD 900

Parameter list (continued)
Service

Description	Display name	Min.	Max.	Factory setting	Unit	Comments
OD %	i50	0	100	-	%	ICM valve Opening Degree
AI [mA]	i51	0	20	-	mA	Analog Input signal
AI [V]	i52	0	10	-	V	Analog Input signal
AO [mA]	i53	0	20	-	mA	Analog Output signal
DI	i54	0	1	-	-	Digital Input signal
DO Close	i55	0	1	-	-	Digital Output Closed status. ON when OD < 3 %
DO Open	i56	0	1	-	-	Digital Output Open status. ON when OD > 97 %
DO Alarm	i57	0	1	-	-	Digital Output alarm status. ON when an alarm is detected
MAS mP SW ver.	i58	0	100	-	-	Software version for MASTER Microprocessor
SLA mP SW ver.	i59	0	100	-	-	Software version for SLAVE Microprocessor

Reset to factory setting :

1. Remove the power supply.
2. Activate down arrow and up arrow push buttons at the same time.
3. Connect the power supply.
4. Release down arrow and up arrow push buttons.
5. When the display on ICAD (fig. 2) is alternating between showing: **CA** and **A1** the factory resetting is complete.