

Introduction

KP thermostats are single-pole, double-throw (SPDT) temperature-operated electric switches.

A KP thermostat can be connected directly to a single-phase alternating current motor of up to approx. 2 kW or installed in the control circuit of direct current motors and large alternating current motors.

KP thermostats are used for regulation, but can also be seen in safety monitoring systems. It is here that the electronic mechanism shows its superiority.

KP thermostats are available with vapour charge or with adsorption charge.

With vapour charge the differential is very small. KP thermostats with adsorption charge are widely used to give frost protection.

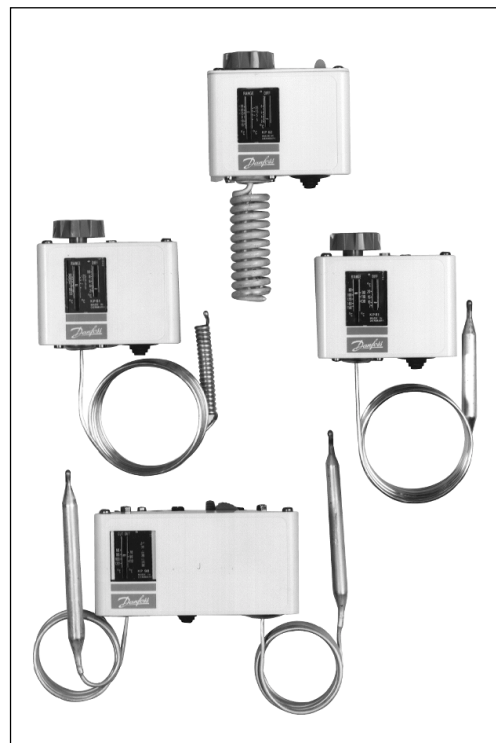

Features

- *Wide regulating range*
- *Can be used for deep freeze, refrigeration and air conditioning plant*
- *Welded bellows elements mean increased reliability*
- *Small dimensions*
Easy to install in refrigerated counters or cold rooms.
- *Ultra-short bounce times*
This gives long operating life, reduces wear to a minimum and increases reliability.
- *Standard versions with changeover switch*
Possible to obtain opposite contact function or to connect a signal.
- *Electrical connection at the front of the unit*
Facilitates rack mounting. Saves space.
- *Suitable for alternating and direct current*
- *Cable entry of soft thermoplastic for cables from 6 to 14 mm diameter.*
- *Extensive and wide range*

Approvals

CE-marked in accordance with EN 60947-4/-5 for sale in Europe.

Ⓜ Germanischer Lloyd, Germany

Ⓜ Polski Rejestr Statków, Poland

DnV, Det norske Veritas, Norway

RINA, Registro Italiano Navale, Italy

BV, France

LR, UK

MRS, Maritime Register of Shipping, Russia

Versions with UL and CSA approvals can be supplied to special order.

Regulating range

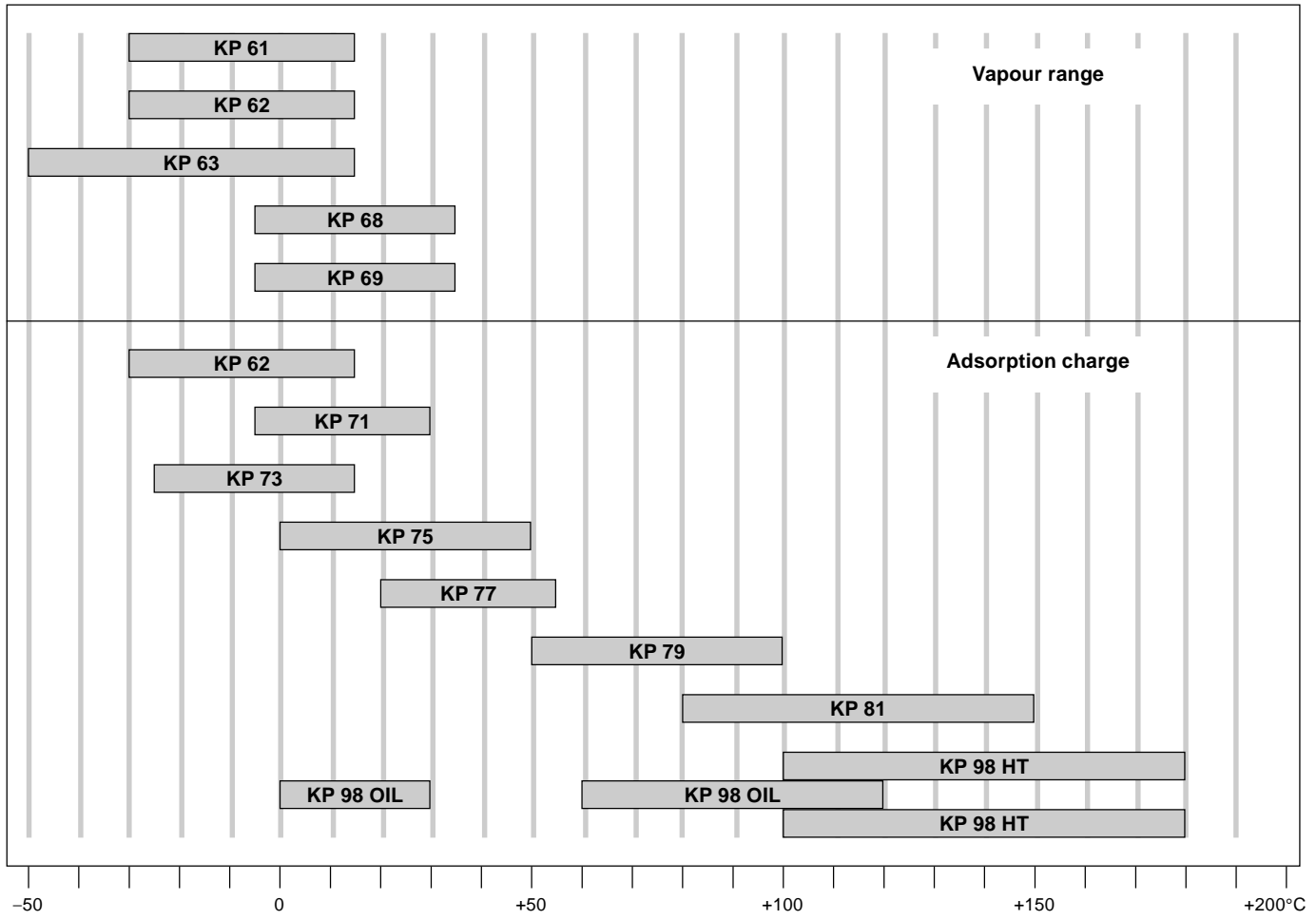

Technical data

Ambient temperature
 -40 → +65°C (+80°C for max. 2 hours).

Switch
 Single-pole, double-throw (SPDT) changeover switch.

Contact load
 Alternating current:
 AC1: 16 A, 400 V
 AC3: 16 A, 400 V
 AC15: 10 A, 400 V
 Max. starting current (L.R.): 112 A, 400 V
 Direct current:
 DC13: 12 W, 220 V control current

Cable connection
 Cable entry for cables 6 → 14 mm dia.
 A Pg 13.5 screwed cable entry can be used for 6 → 14 mm dia. cables.
 With 8 → 16 mm cables a standard Pg 16 screwed cable entry can be used.

Enclosure
 IP 33 to IEC 529
 This grade of enclosure is obtained when the unit is mounted on a flat surface or bracket.
 The bracket must be fixed so that all unused holes are covered.

Contact systems

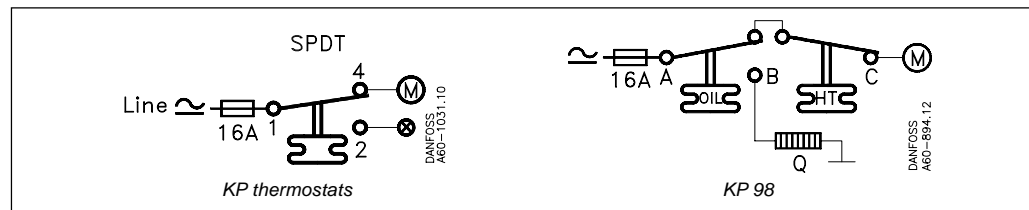

Ordering

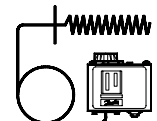





Charge	Type	Bulb type	Setting range °C	Differential Δt		Reset	Max. bulb temp. °C	Capillary-tube length m	Code no.
				Lowest temperature °C	Highest temperature °C				
Vapour ¹⁾	KP 61	A	-30 → 15	5.5 → 23	1.5 → 7	Aut.	120	2	060L1100
	KP 61	A	-30 → 15	5.5 → 23	1.5 → 7	Aut.	120	5	060L1101
	KP 61	B	-30 → 13	4.5 → 23	1.2 → 7	Aut.	120	2	060L1102
	KP 61	B	-30 → 15	5.5 → 23	1.5 → 7	Aut.	120	2	060L1103 ³⁾
	KP 61	B	-30 → 15	5.5 → 23	1.5 → 7	Aut.	120	2	060L1128 ³⁾ ⁴⁾
	KP 61	A	-30 → 15	Fixed 6	Fixed 2	Min.	120	5	060L1104
	KP 61	B	-30 → 15	Fixed 6	Fixed 2	min.	120	2	060L1105
	KP 61	B	-30 → 13	4.5 → 23	1.2 → 7	Aut.	120	3	060L1180
	KP 62	C 1	-30 → 15	6.0 → 23	1.5 → 7	Aut.	120		060L1106
	KP 63	A	-50 → -10	10.0 → 70	2.7 → 8	Aut.	120	2	060L1107
	KP 63	B	-50 → -10	10.0 → 70	2.7 → 8	Aut.	120	2	060L1108
	KP 68	C 1	-5 → 35	4.5 → 25	1.8 → 7	Aut.	120		060L1111
	KP 69	B	-5 → 35	4.5 → 25	1.8 → 7	Aut.	120	2	060L1112
Adsorption ²⁾	KP 62	C 2	-30 → 15	5.0 → 20	2.0 → 8	Aut.	80		060L1110 ³⁾ ⁴⁾
	KP 71	E 2	-5 → 20	3.0 → 10	2.2 → 9	Aut.	80	2	060L1113
	KP 71	E 2	-5 → 20	Fixed 3	Fixed 3	min.	80	2	060L1115
	KP 73	E 1	-25 → 15	12.0 → 70	8.0 → 25	Aut.	80	2	060L1117
	KP 73	D 1	-25 → 15	4.0 → 10	3.5 → 9	Aut.	80	2	060L1118 ³⁾
	KP 73	D 1	-25 → 15	Fixed 3.5	Fixed 3.5	min.	80	2	060L1138
	KP 73	D 2	-20 → 15	4.0 → 15	2.0 → 13	Aut.	55	3	060L1140
	KP 73	D 1	-30 → 15	3.5 → 20	3.25 → 18	Aut.	80	2	060L1143
	KP 75	F	0 → 35	3.5 → 16	2.5 → 12	Aut.	110	2	060L1120
	KP 75	E 2	0 → 35	3.5 → 16	2.5 → 12	Aut.	110	2	060L1137
	KP 77	E 3	20 → 60	3.5 → 10	3.5 → 10	Aut.	130	2	060L1121
	KP 77	E 3	20 → 60	3.5 → 10	3.5 → 10	Aut.	130	3	060L1122
	KP 77	E 2	20 → 60	3.5 → 10	3.5 → 10	Aut.	130	5	060L1168
	KP 79	E 3	50 → 100	5.0 → 15	5.0 → 15	Aut.	150	2	060L1126
	KP 81	E 3	80 → 150	7.0 → 20	7.0 → 20	Aut.	200	2	060L1125
	KP 81	E 3	80 → 150	Fixed 8	Fixed 8	Max.	200	2	060L1155
KP 98	E 2	OIL: 60 → 120	OIL: Fixed 14	OIL: Fixed 14	Max.	150	1	060L1131	
	E 2	HT: 100 → 180	HT: Fixed 25	HT: Fixed 25	Max.	250	2		

- ¹⁾ Bulb must always be placed colder than the thermostat housing and capillary tube. The thermostat will then regulate independent of ambient temperature.
- ²⁾ Bulb can be placed warmer or colder than thermostat housing and capillary tube, but variations from +20°C ambient temperature will influence the scale accuracy.
- ³⁾ With manual switch, not isolating switch.
- ⁴⁾ Panel mounting model with top plate.

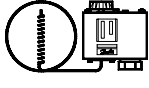
Ordering
(continued)

Thermostat bulb types

A		Straight capillary tube
B		Ø 9.5 × 70 mm remote air coil
C		C1: Ø 40 × 30 mm air coil C2: Ø 25 × 67 mm air coil (integral with thermostat)
D		D1: Ø 10 × 85 mm double contact remote bulb D2: Ø 16 × 170 mm double contact remote bulb Note! Cannot be used in sensor (bulb) pocket
E		E1: Ø 6.4 × 95 mm remote bulb E2: Ø 9.5 × 115 mm remote bulb E3: Ø 9.5 × 85 mm remote bulb
F		Ø 25 × 125 mm remote duct coil

Design Function

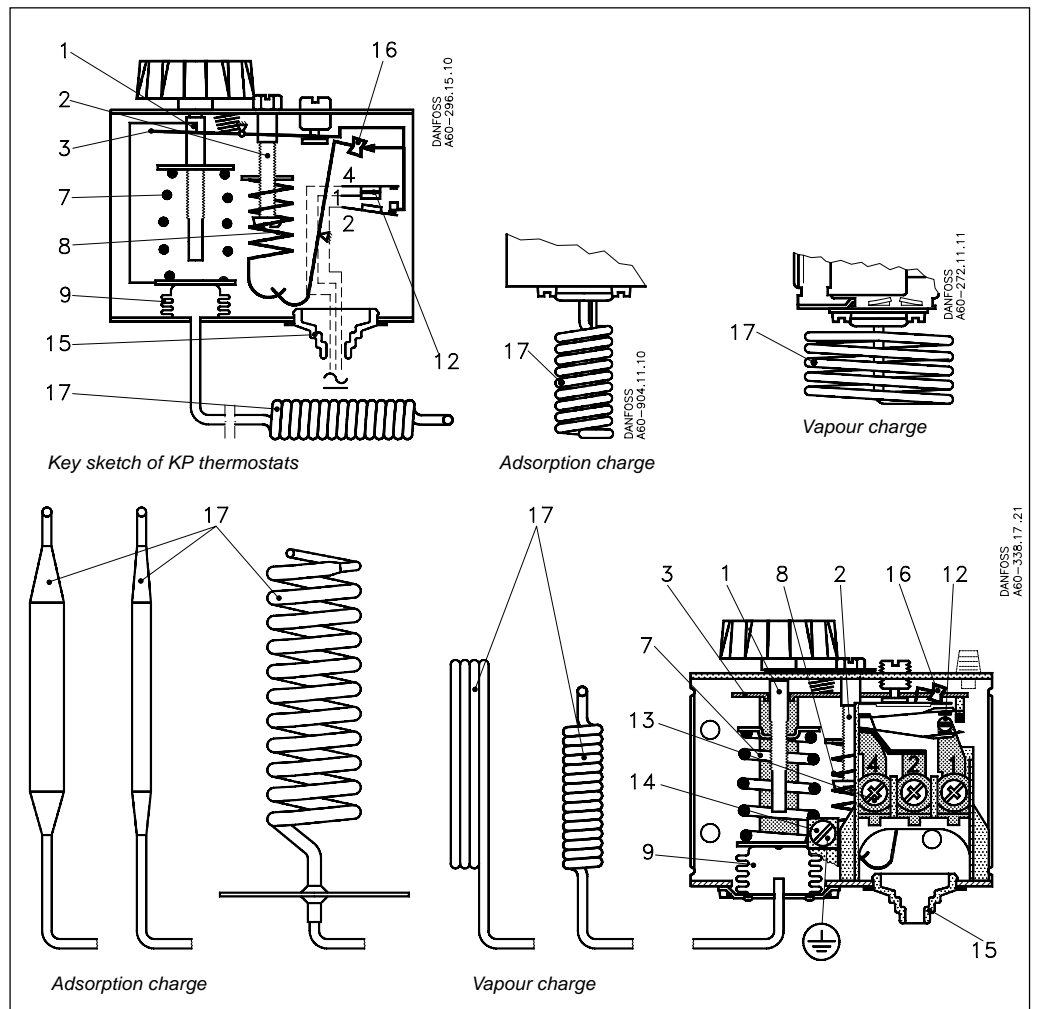

- 1. Temperature setting spindle
- 2. Differential setting spindle
- 3. Main arm
- 7. Main spring
- 8. Differential spring
- 9. Bellows
- 12. Switch
- 13. Terminals
- 14. Earth terminal
- 15. Cable entry
- 16. Tumbler
- 17. Sensor

The switch in the KP has a snap-action function and the bellows move only when the cut-in or cut-out value is reached.

The design of the KP thermostat affords the following advantages:

- high contact load
- ultra-short bounce time
- vibration resistance up to 4 g in the range 0-1000 Hz
- long mechanical and electrical life.

Design Function
(continued)

- 1. Temperature setting spindle, OIL
- 3. Main arm
- 5. Temperature setting spindle, HT
- 7. Main spring
- 9. Bellows
- 10. Capillary tube, OIL
- 11. Capillary tube, HT
- 12. Switch
- 13. Terminals
- 14. Earth terminal
- 15. Cable entry
- 16. Tumbler
- 17. Sensor (bulb)
- 18. Locking plate

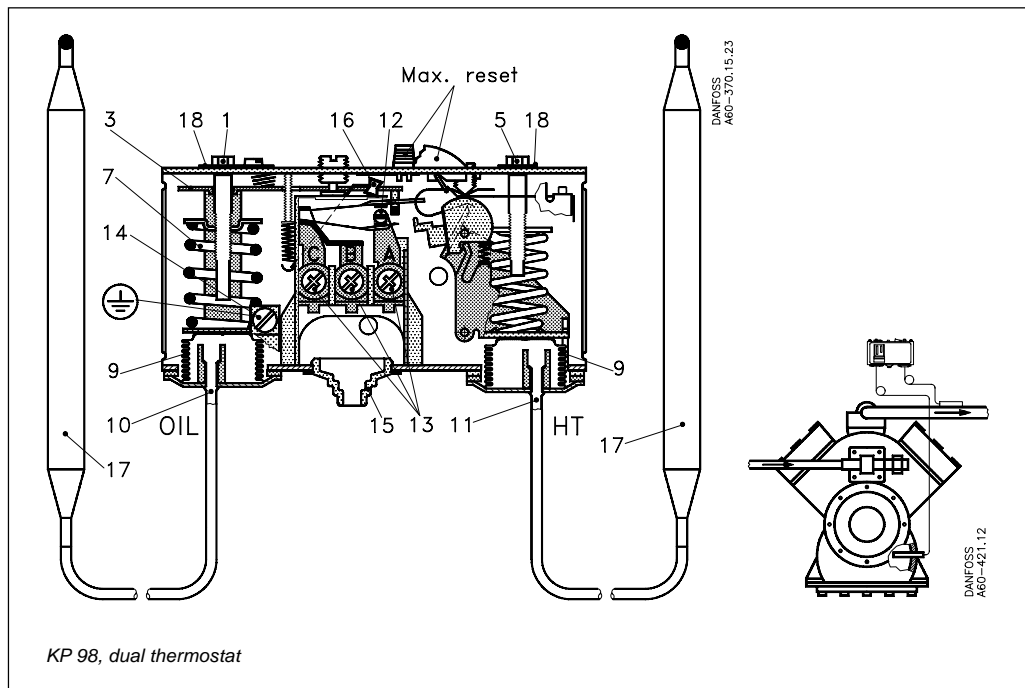

KP 98, dual thermostat

Dual thermostat KP 98 is used to provide protection against excessively high discharge gas temperature and to ensure a suitable oil temperature in the compressor.

To avoid the temperature of the hot gas exceeding the maximum permissible value during extreme operating conditions (low evaporating pressure, high condensing pressure, high suction vapour superheat) a KP 98 thermostat can be used on the high temperature side (HT). If the temperature of the hot gas becomes too high the refrigerant will break down and the compressor discharge valve will become damaged.

The risk is greatest in refrigeration systems that operate on a high compression ratio (e.g. in systems with NH₃ or R 22) and in applications with hot gas bypass.

This unit has two separate thermostat functions. The HT sensor that controls the discharge gas temperature is fitted on the discharge tube immediately after the compressor.

For larger compressors, the sensor can be built into the discharge line.

The OIL sensor that controls the oil temperature is located in the compressor oil sump.

Terminology

Differential

The differential is the difference between the make and break temperatures. A differential is necessary for satisfactory automatic operation of the plant.

Mechanical differential (intrinsic differential)

The mechanical differential is the differential set by the differential spindle.

Operating differential (thermal differential)

The operating differential is the differential the plant operates on. Operating differential is the sum of the mechanical differential and the differential produced by the time constant.

Reset

1. Manual reset:

Units with manual reset can only be restarted after the reset button has been activated. On min. reset units the set value is equal to the cut-out value for falling temperature. On max. reset units the set value is equal to the cut-out value for rising temperature.

2. Automatic reset:

These units are automatically reset after operational stop.

Setting

Thermostats with automatic reset

Set the upper activating temperature on the range scale.
 Set the differential on the "DIFF" scale.
 The temperature setting on the range scale will then correspond to the temperature at which the refrigeration compressor will be started on rising temperature. The compressor will be stopped when the temperature has fallen in relation to the differential setting.
 Note that the differential depends on the range setting. Therefore, the differential scale must only be used as guideline.
 If with low stop temperature settings the compressor will not stop, check whether the differential is set at too high a value!

Thermostats with minimum reset

Set the stop temperature on the range scale.
 The differential is a fixed setting.
 The compressor can be restarted by pressing the "Reset button" after the temperature on the thermostat sensor has risen by a value equal to the fixed differential setting.

Thermostats with maximum reset

Set the stop temperature on the range scale.
 The differential is a fixed setting.
 The compressor can be restarted by pressing the "Reset button" after the temperature on the thermostat sensor has fallen to a value equal to the fixed differential setting.

Charges

1. Vapour charge

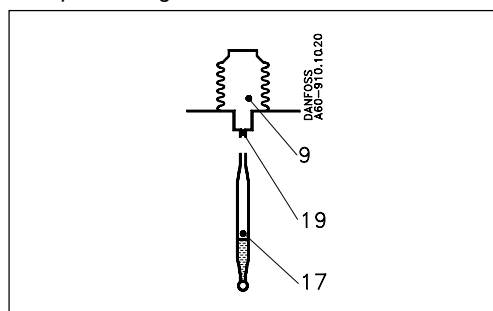

- 9. Bellows element
- 17. Sensor (bulb)
- 19. Capillary tube

Here the interdependence between the pressure and temperature of saturated vapour is utilized, i.e. the element is charged with saturated vapour plus a small amount of liquid. The charge is pressure-limited; a further increase in pressure after evaporation of all the liquid in the sensor (17) will only result in a small pressure increase in the element.

This principle can be utilized in thermostats for low temperature, etc. where evaporation must be able to take place from the free liquid surface in the sensor (within the operating range of the thermostat), and where at the same time, the bellows must be protected against deformation when kept at normal ambient temperatures. Since the pressure in the element depends on the temperature at the free liquid surface, the thermostat must always be placed so that the sensor is colder than the rest of the thermostatic element.

The evaporated liquid will recondense at the coldest point, i.e. the sensor. Thus, as intended, the sensor becomes the temperature-controlling part of the system.

Note: When the sensor is coldest, the ambient temperature has no effect on regulating accuracy.

2. Adsorption charge

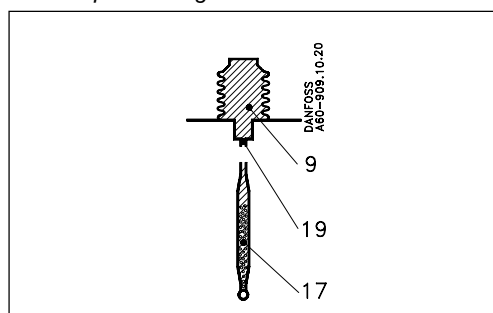

- 9. Bellows element
- 17. Sensor (bulb)
- 19. Capillary tube

In this case the charge consists partly of a superheated gas and partly of a solid having a large adsorption surface.

The solid is concentrated in the sensor (17) and it is therefore always the sensor that is the temperature-controlling part of the thermostatic element.

The sensor can be placed warmer or colder than thermostat housing and capillary tube, but variations from +20°C ambient temperature will influence the scale accuracy.

Dimensions and weights

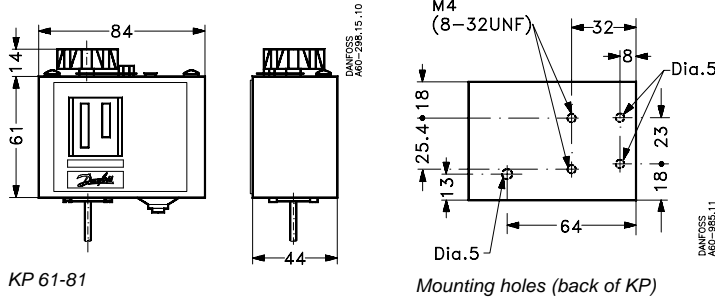

Weight
 KP 61-81: approx. 0.4 kg
 KP 98: approx. 0.6 kg

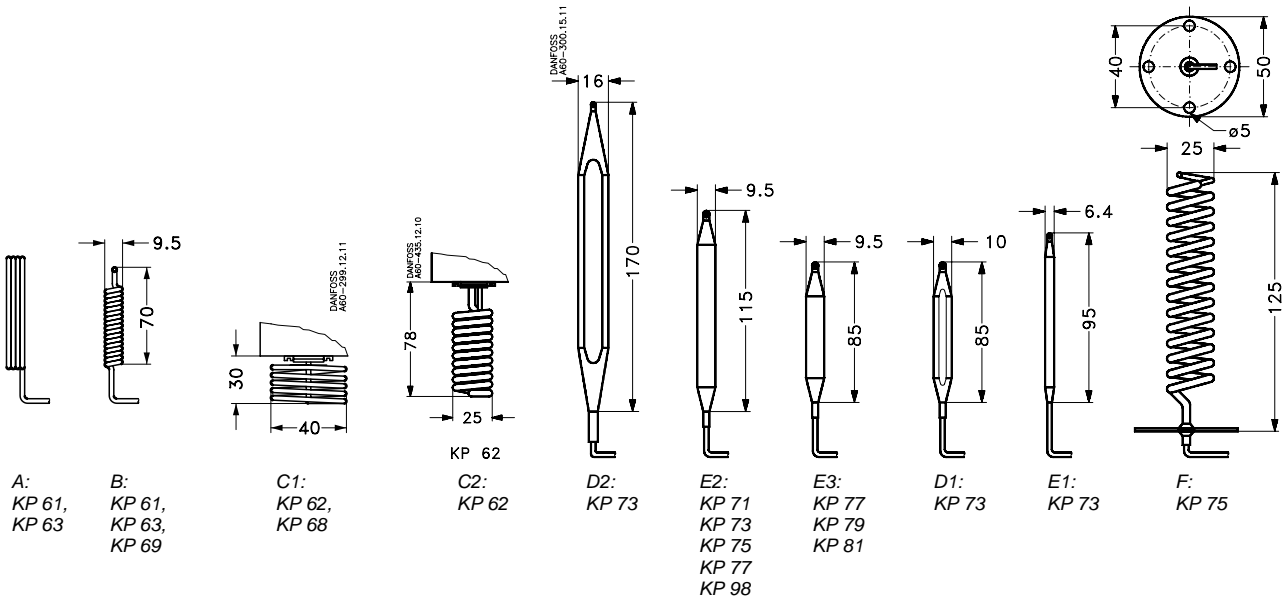
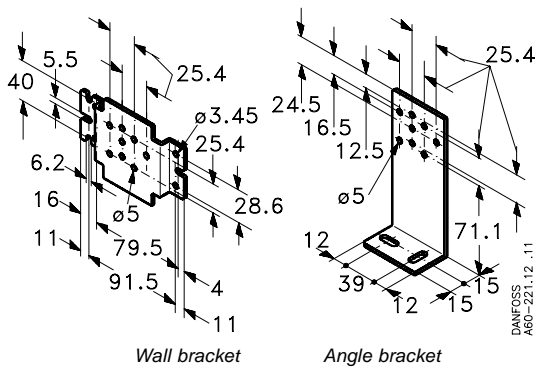
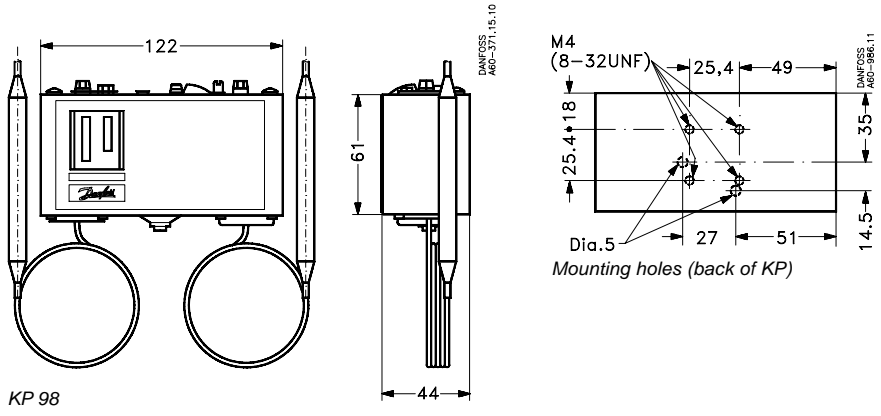

Danfoss can accept no responsibility for possible errors in catalogues, brochures and other printed material. Danfoss reserves the right to alter its products without notice. This also applies to products already on order provided that such alterations can be made without subsequential changes being necessary in specifications already agreed. All trademarks in this material are property of the respective companies. Danfoss and the Danfoss logotype are trademarks of Danfoss A/S. All rights reserved.



DK-6430 Nordborg
Denmark